

Digitized Automation for a Changing World

<https://uset techno.com/>

Delta Hybrid Servo Drive VFD-VJ Series Servo Motor MSJ/MSO Series



www.deltaww.com

 **DELTA**
Smarter. Greener. Together.



Delta Hybrid Servo Drive VFD-VJ Series Servo Motor MSJ/MSO Series

Hydraulic systems have been widely adopted as control systems for injection molding machinery, featuring high power density, excellent pressure and flow control, long service life design, and easy maintenance. A hydraulic system using an AC servo drive provides a fast response rate, higher duplication accuracy and constant torque to the system. It is a perfect integration of servo drive, motor and hydraulic technology. With precise control of pressure and flow, the hybrid servo system eliminates the energy waste to save the cost of proportional valves for pressure flow control, and improves the control system for injection molding machinery, enhancing market competitiveness.

With years of commitment to the plastic and rubber industries, Delta has developed the Hybrid Servo Drive VFD-VJ Series with superior drive performance and system integration capabilities. Compared with other products on the market, Delta's VFD-VJ Series features excellent overload capability and high power density, enabling users to choose suitable models with less power for efficient cost saving. The VFD-VJ-C Series supports IPM motor parameter self-learning and various protection functions. For applications, it provides fan-cooled and oil-cooled types, enabling stable operations for a variety of environments and conditions.

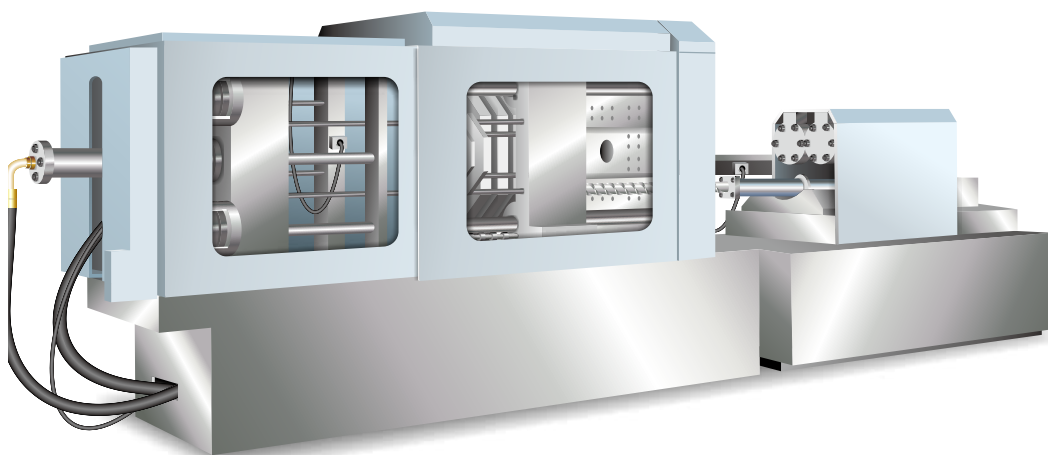

Model Explanation of Hybrid Servo Drive

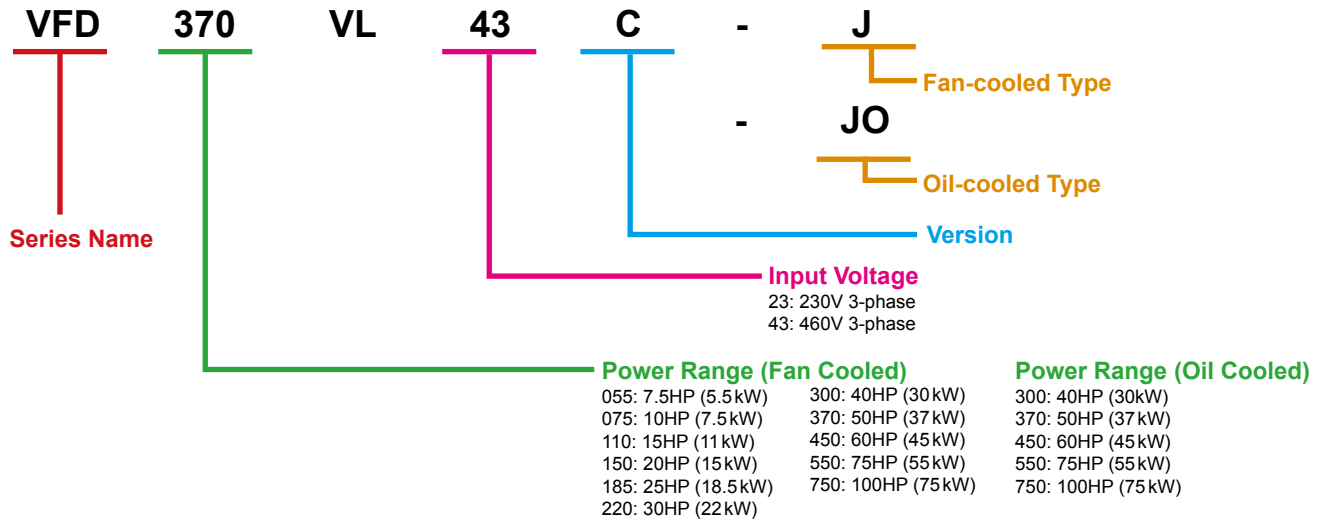

Long Pressure Holding Time

Easier Communication Integration

Low System Temperature

Good Pressure Response

Ultra Energy-Saving

High Durability
*Oil cooled type

Highly Accurate Repeatability

Various Protection Functions



Injection Molding Machine with Hybrid Servo System

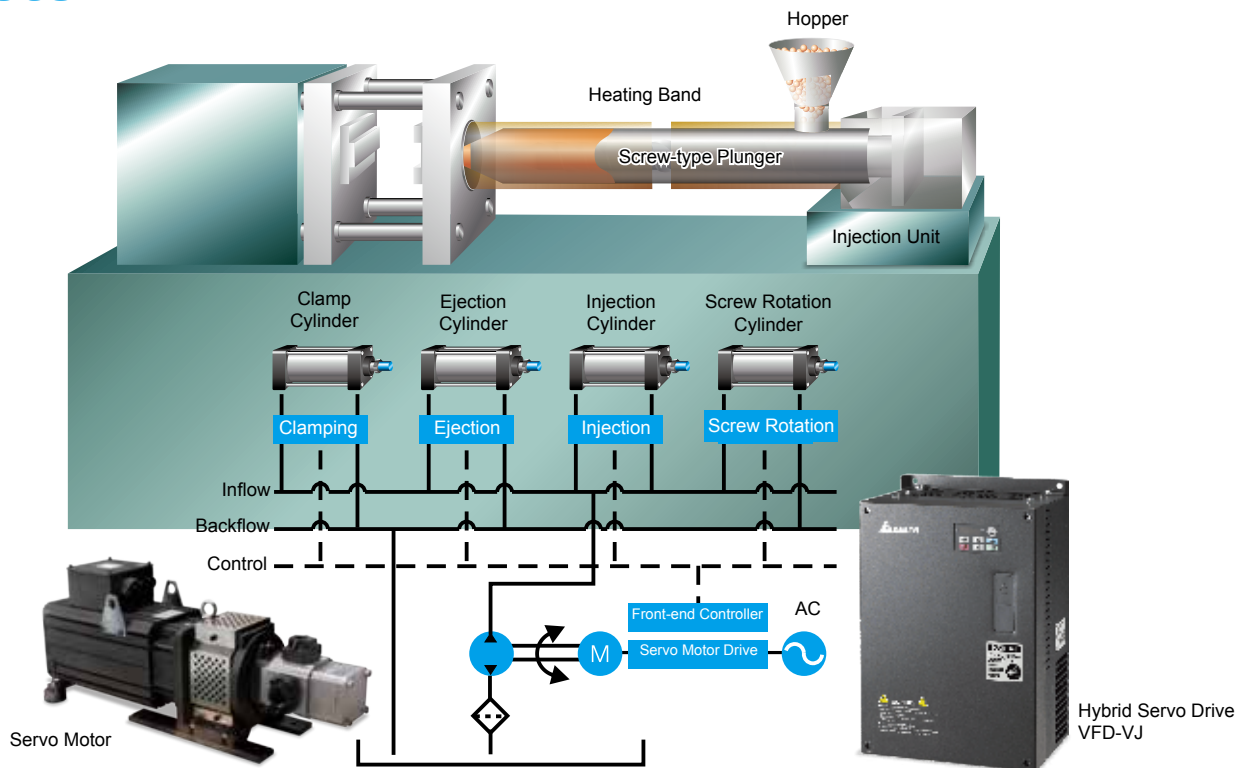

Structure of the Hybrid Servo System

After receiving pressure and flow commands from the injection molding machine controller, the VFD-VJ performs PID calculations with actual pressure and speed feedback to drive the servo motor and hydraulic pump with a quick response time and high repeatability.

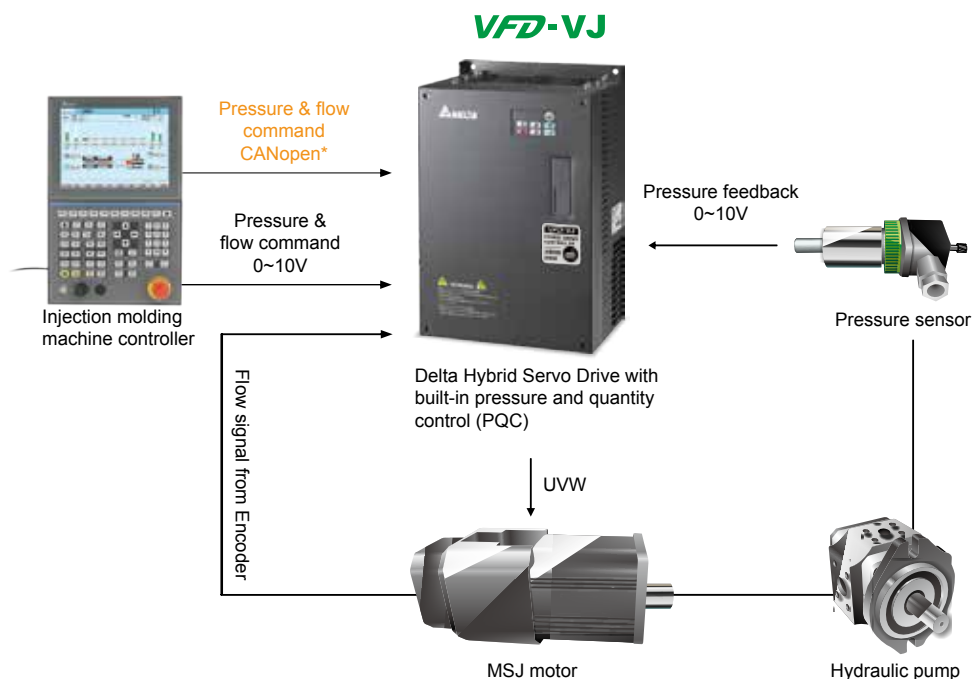

*For VFD-VJ-C Series only

Hybrid Energy System Features

(1) Significant reduction in energy consumption

- Saves up to **60%** electricity compared to traditional injection molding machines (fixed displacement pump) during pressure holding and cooling processes

Energy-consumption curve during injection molding

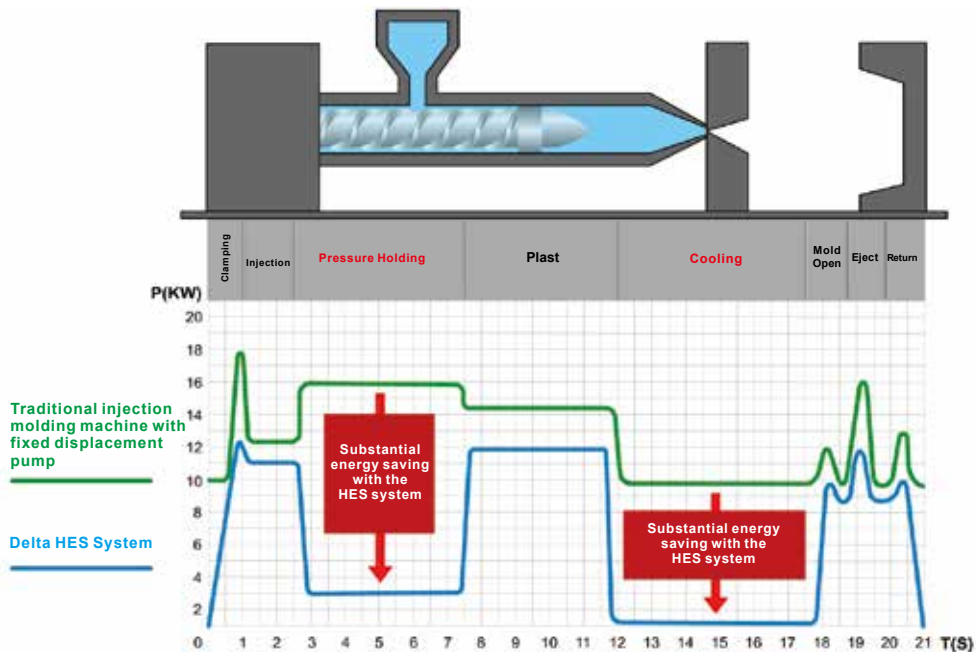

- Traditional injection molding machine uses a relief valve or proportional valve to control the pressures and the flows during mold closing, injection, pressure holding and mold opening, while the Delta HES system enables automatic adjustment according to different injection conditions, reducing up to **75%** in energy consumption.

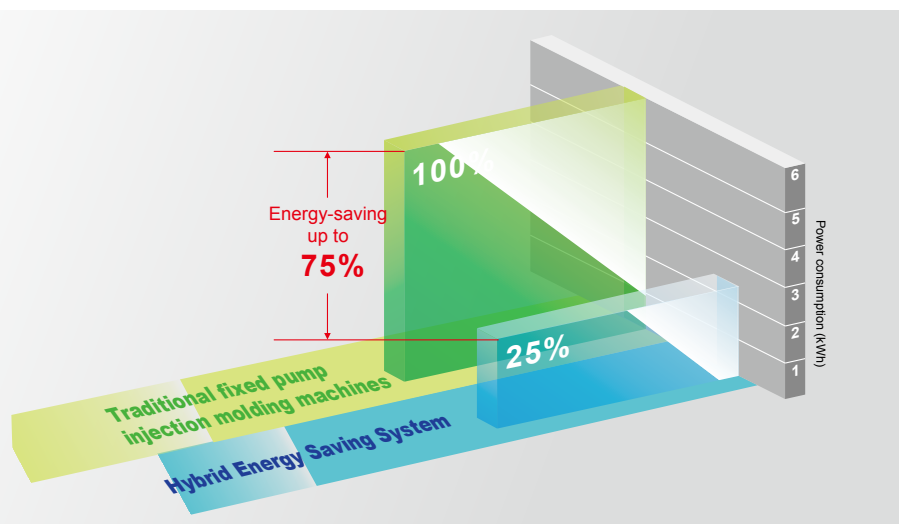

Hybrid Energy System Features

(2) Low system temperature

Lowers oil temperature by 5~10°C and saves costs on oil cooler

(3) Highly accurate repeatability

Precise flow and pressure control

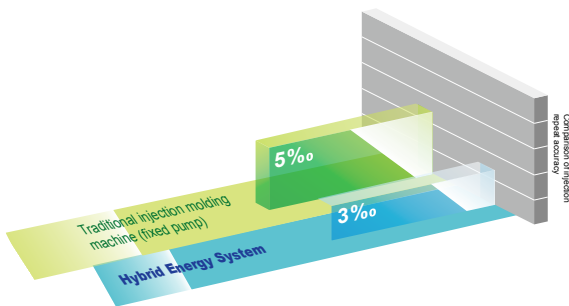

(4) Long pressure holding time

Benefits of thicker-walled parts and complex parts with both thick and thin walls

(5) Easier communication integration

Supports CANopen communication protocol for data transmission

(6) Fast frequency response

High dynamic performance (ability to respond and control pressure and velocity changes) is suitable for high-speed injection molding machines.

(7) Good field-weakening control

Increases output voltage, decreases output current and maintains sine wave output to reduce motor damage and vibration

(8) Easy to use (VFD-VJ-C Series)

Provides 5-digit LED keypad and left shift button to increase operational convenience



(9) Multiple protection functions

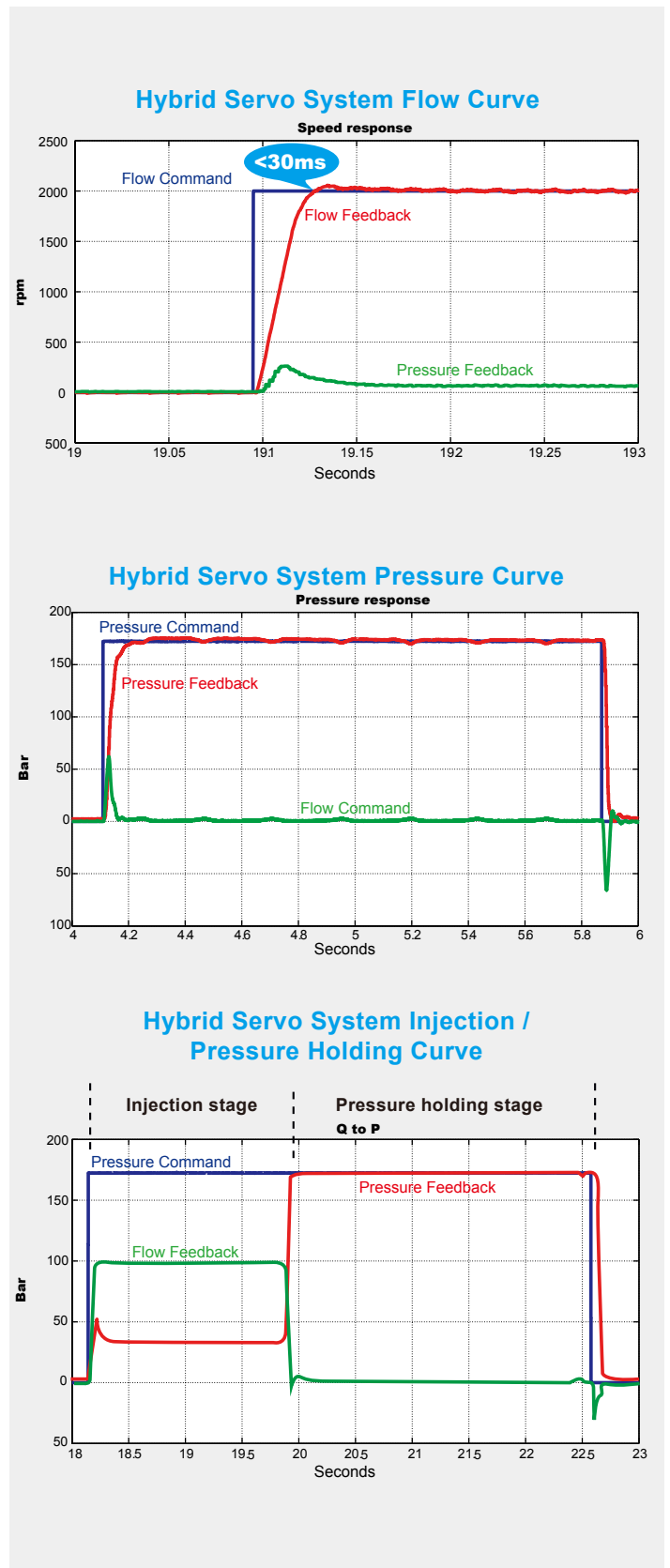

Specifications

Fan Cooled Type (VFD-VJ-A / VFD-VJ-B Series)

230V							
Frame	C			D			
Model Number VFD-__VL23_-J	055 A	075 A	110 A	150 A	185 A	220 A	
Power (kW)	5.5	7.5	11	15	18.5	22	
Horsepower (HP)	7.5	10	15	20	25	30	
Output	Rated Output Current (A)	21.9	27.1	41.1	53	70	79
	Continuous Output Current (A) for 60 sec	33	46	62	90	119	119
	Continuous Output Current (A) for 20 sec	37	54	70	106	140	134
	Carrier Frequency (Hz)	5k/10k					
Power	Input Current (A)	23	30	47	56	73	90
	Rated Input Voltage (V)	3-phase 200 ~ 240VAC, 50/60Hz					
	Mains Voltage Tolerance	±10% (180 ~ 264V)					
	Mains Frequency Tolerance	±5% (47 ~ 63Hz)					
Weight (kg)	8	10		13			
Brake Unit	Built-in						

460V										
Frame	C					D		E0	E3	
Model Number VFD__VL43_-J	055 A	075 A	110 A	150 B	185 B	220 A	300 B	370 B	450 B	
Power (KW)	5.5	7.5	11	15	18.5	22	30	37	45	
Horsepower (HP)	7.5	10	15	20	25	30	40	50	60	
Output	Rated Output Current (A)	12.3	15.8	21	27	34	41	60	73	91
	Continuous Output Current (A) for 60 sec	21	27	36	46	58	62	102	124	155
	Continuous Output Current (A) for 20 sec	25	32	42	54	68	78	120	146	182
	Carrier Frequency (Hz)	5k/10k								
Power	Input Current (A)	14	17	24	30	37	47	60	73	91
	Rated Input Voltage (V)	3-phase 380 ~ 480VAC, 50/60Hz								
	Mains Voltage Tolerance	±10% (342 ~ 528V)								
	Mains Frequency Tolerance	±5% (47 ~ 63Hz)								
Weight (kg)	8	10	10	10	10	13	13	36	36	
Brake Unit	Built-in							External		

* Delta reserves the right to revise specifications without prior notice.

General Specifications		
Control Method	SVPWM	
Speed Detector	Resolver / Incremental Encoder	
Speed Input Command	DC 0~10V, supports 3-point adjustment for analog inputs	
Pressure Input Command	DC 0~10V, supports 3-point adjustment for analog inputs	
Pressure Feedback Command	Voltage type DC 0 ~ 10V and current type 4 ~ 20mA (Firmware version V2.04 and the new I/O board are required. For detailed instructions, please refer to the user manual, parameter 03-12)	
General Input Signal	5 ch DC24V	
General Output Signal	2 ch DC48V 50mA ; 1 ch Relay output	
Analog Output Voltage	2 ch DC 0 ~ 10V 2mA	
Optional Accessories	Speed Feedback PG Card	Required (refer to appendix A-5)
	Brake Resistor	Required (refer to appendix A-1)
	Pressure Sensor	Required (compatible to pressure sensor with output signal 0 ~ 10V or 4 ~ 20mA. Please use parameter 03-10, 03-11, 03-12 for output signal settings and parameter 00-08 for max. pressure setting)
	EMC Filter	Optional (refer to Appendix A-7)
Protections	Motor Protection	Electronic thermal relay protection Real-time temperature monitoring and protection
	Over-current	300% of rated current
	Ground Leakage Current	Higher than 50% rated current
	Voltage Protection	Over-voltage level: VDC > 415/830V; Low-voltage Level: VDC < 180/360V
	Mains Input Over-Voltage	Varistor (MOV)
	Over-temperature	Built-in temperature sensor
Environment	Protection Level	NEMA 1/IP20
	Operation Temperature	-10 °C ~ 45 °C
	Storage Temperature	-20 °C ~ 60 °C
	Humidity	< 90% RH (non-condensing)
	Vibration	< 20Hz: 1.0; 20 to 60Hz: 0.6G
	Cooling System	Forced air cooling (Drive RUN: Fan ON, Drive STOP: Fan OFF)
	Installation Location	Altitude 1,000m or lower (keep away from corrosive gasses, liquid and dust)
Certifications		

* Delta reserves the right to revise specifications without prior notice.

Fan Cooled Type (VFD-VJ-C Series)

230V		
Frame	E4	
Model Number VFD__VL23_-J	300 C	370 C
Power (KW)	30	37
Horsepower (HP)	40	50
Output	Rated Output Current (A)	120
	Continuous Output Current (A) for 60 sec	204
	Continuous Output Current (A) for 20 sec	240
	Carrier Frequency (Hz)	4k~10k adjustable
Power	Input Current (A)	120
	Rated Input Voltage (V)	3-phase 200 ~ 240VAC, 50/60Hz
	Mains Voltage Tolerance	-15%, +10% (170 ~ 264V)
	Mains Frequency Tolerance	±5% (47 ~ 63Hz)
Weight (kg)	44	
Brake Unit	Built-in	

460V										
Frame	C				D		E4			
Model Number VFD__VL43_-J	110 C	150 C	185 C	220 C	300 C	370 C	450 C	550 C	750 C	
Power (KW)	11	15	18.5	22	30	37	45	55	75	
Horsepower (HP)	15	20	25	30	40	50	60	75	100	
Output	Rated Output Current (A)	21	27	34	41	60	73	91	110	
	Continuous Output Current (A) for 60 sec	36	46	58	70	102	110	155	187	
	Continuous Output Current (A) for 20 sec	42	54	68	82	120	124	182	220	
	Carrier Frequency (Hz)	4k~10k adjustable								
Power	Input Current (A)	24	30	37	47	60	73	91	110	
	Rated Input Voltage (V)	3-phase 380 ~ 480VAC, 50/60Hz								
	Mains Voltage Tolerance	-15%, +10% (323 ~ 528V)								
	Mains Frequency Tolerance	±5% (47 ~ 63Hz)								
Weight (kg)	9				13		46	46		
Brake Unit	Built-in									

* Delta reserves the right to modify specifications without prior notice.

Oil Cooled Type (VFD-VJ-C Series)

460V						
Frame	E5					
Model Number VFD__VL43C-JO	300 C	370 C	450 C	550 C	750 C	
Power (KW)	30	37	45	55	75	
Horsepower (HP)	40	50	60	75	100	
Output	Rated Output Current (A)	60	73	91	110	150
	Continuous Output Current (A) for 60 sec	102	124	155	187	255
	Continuous Output Current (A) for 20 sec	120	146	182	220	300
	Carrier Frequency (Hz)	4k ~ 10k adjustable				
Power	Input Current (A)	60	73	91	110	150
	Rated Input Voltage (V)	3-phase 380 ~ 480VAC, 50/60Hz				
	Mains Voltage Tolerance	-15%, +10% (323 ~ 528V)				
	Mains Frequency Tolerance	±5% (47 ~ 63Hz)				
Weight (kg)	40					
Cooling Methods	Forced-oil cooling (oil temperature 10 ~ 50 °C) Hydraulic oil HL-HLP DIN 51524 Part1/2 R68, R46					
Cooling Flow Requirement (L/Min.)	16				32	
Brake Unit	Built-in					

* Delta reserves the right to revise specifications without prior notice.

General Specifications		
Control Method	SVPWM	
Speed Detector	Resolver	
Speed Input Command	DC 0~10V, Supports 3-point adjustment for analog inputs	
Pressure Input Command	DC 0~10V, Supports 3-point adjustment for analog inputs	
Pressure Feedback Command	Voltage Type DC 0 ~ 10V and Current Type 4 ~ 20mA (Please refer to Pr. 03-12 for more details)	
General Input Signal	6 ch DC24V	
General Output Signal	2 ch DC 48V 50mA (max); 1 ch Relay output	
Analog Output Voltage	1ch DC 0 ~ 10V 及 -10 ~ 10V 2mA	
Communication Port	RJ45x2, USBx1	
Communication Protocol	CANopen and MODBUS (can be used at same time)	
Optional Accessories	Speed Feedback PG Card	Built-in
	Multiple Drives Convergent Flow Communication Card	Built-in
	Brake Resistor	Required (refer to Appendix A-1 of manual)
	Pressure Sensor	Required (compatible to pressure sensor with output signal 0 ~ 10V or 4 ~ 20mA. Please use parameter 03-10, 03-11, 03-12 for output signal settings and parameter 00-08 for max. pressure setting)
	EMC Filter	Optional (refer to Appendix A-7 of Manual)
Protections	Motor Protection	Real-time temperature monitoring and protection, electronic thermal relay protection (supports KTY84-130/ PTC/ temperature switch)
	Over-current	Over-current protection on output and braking
	Ground Leakage Current	Higher than 80% rated current
	Voltage Protection	Over-voltage level: VDC > 415/830V; low-voltage level: VDC < 180/360V
	Mains Input Over-voltage	Varistor (MOV)
	Over-temperature	Capacitor, IGBT, braking chopper, motor temperature
	Brake Resistor Protection	Alert issued when low resistor value or no value detected
	Oil Shortage Protection	Prevents damage of the components in oil pump due to lack of oil
Environment	Protection Level	NEMA 1/IP20
	Operation Temperature	-10 °C ~ 45°C
	Storage Temperature	-20 °C ~ 60°C
	Humidity	< 90% RH (non-condensing)
	Vibration	< 20Hz: 1.0G; 20 to 60Hz: 0.6G
	Installation Location	Altitude 1,000m or lower (keep away from corrosive gasses, liquid and dust)
Certifications		

* Delta reserves the right to modify specifications without prior notice.

* Currently obtaining UL certification for the 230 V model of the VFD-VJ-C Series.

Wiring

Fan Cooled Type with Built-in Brake Unit (VFD-VJ-A / VFD-VJ-B Series)

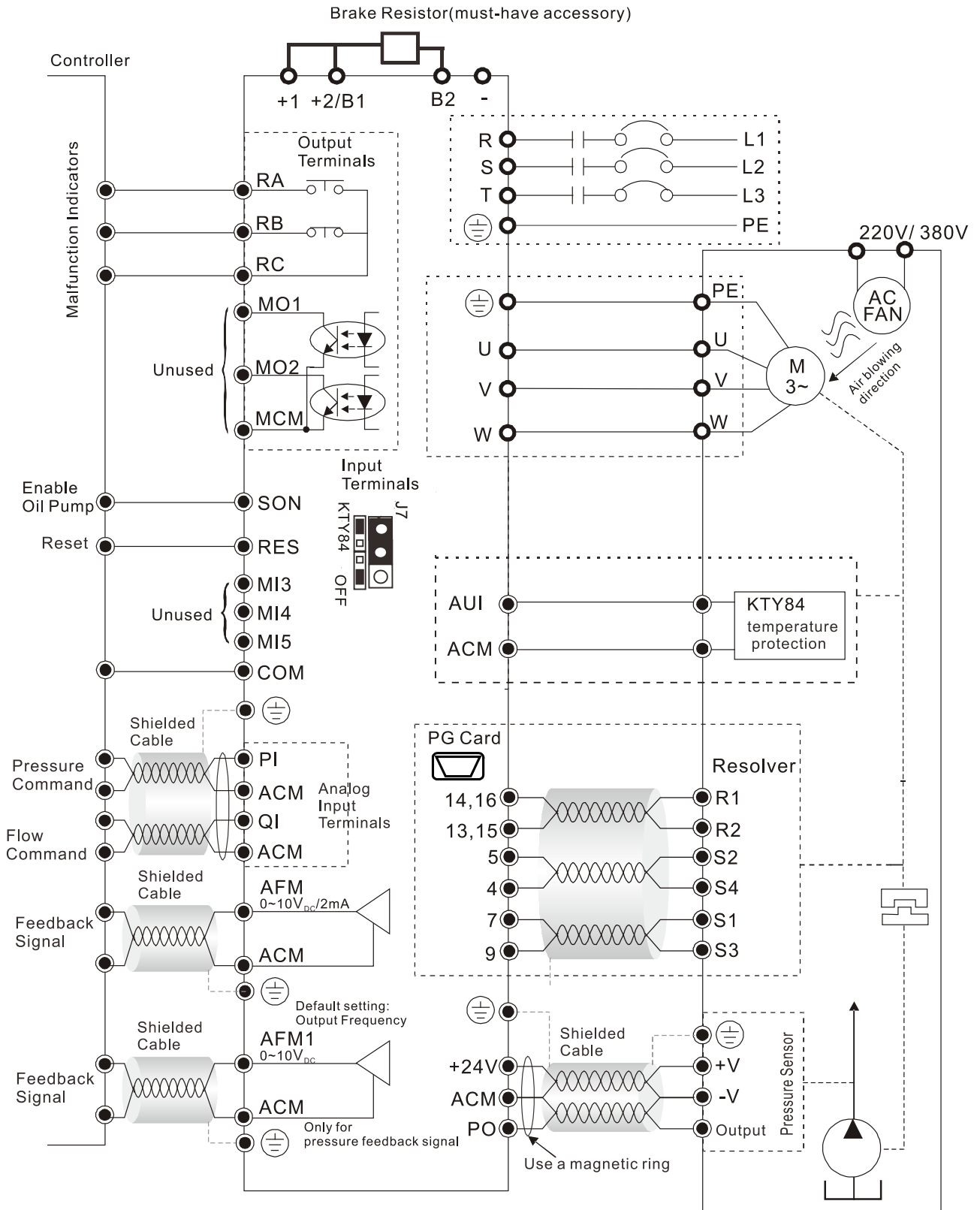

Wiring

Fan Cooled Type with External Brake Unit (VFD-VJ-A / VFD-VJ-B Series)

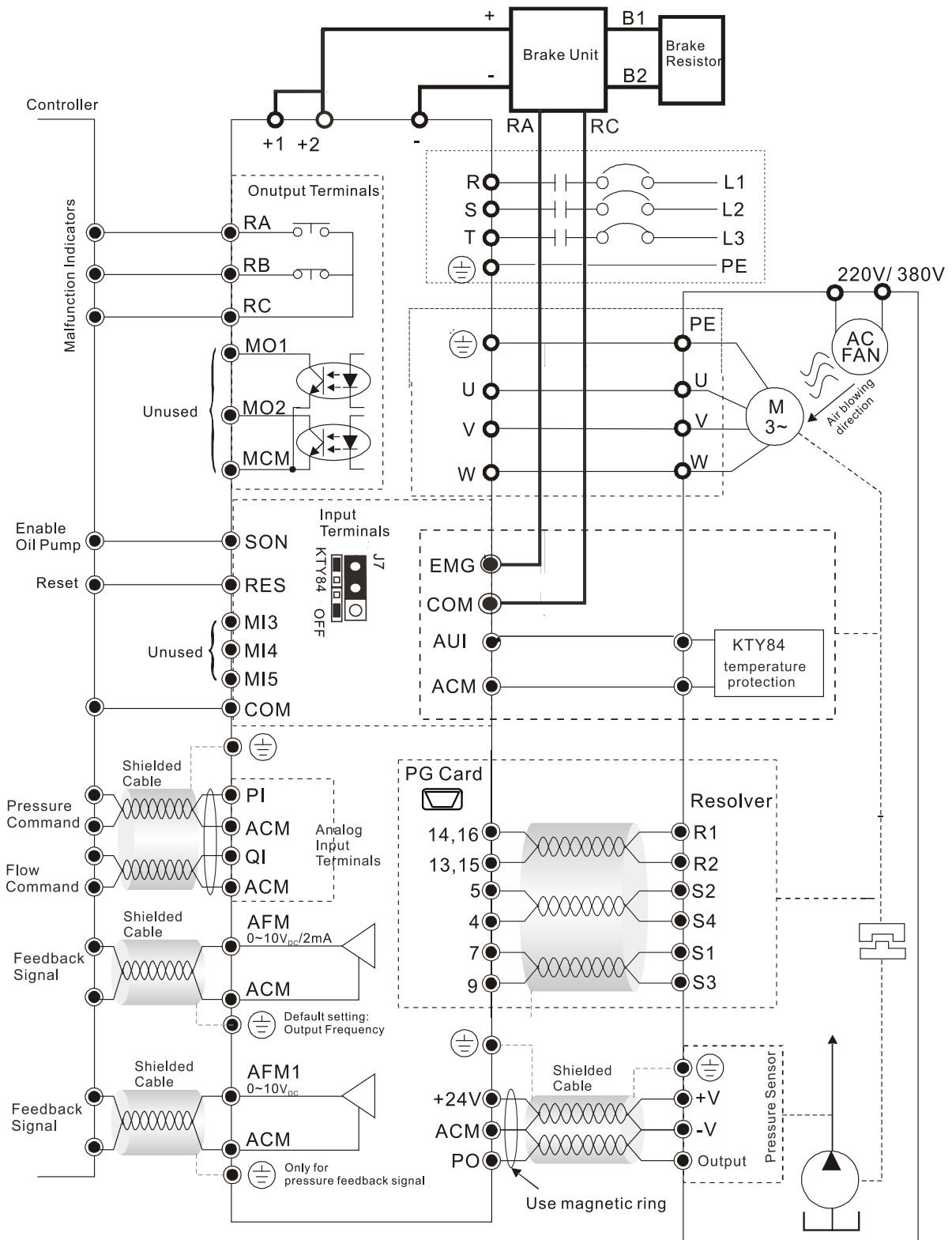

Wiring

Fan Cooled / Oil Cooled Types with Built-in Brake Unit (VFD-VJ-C Series)

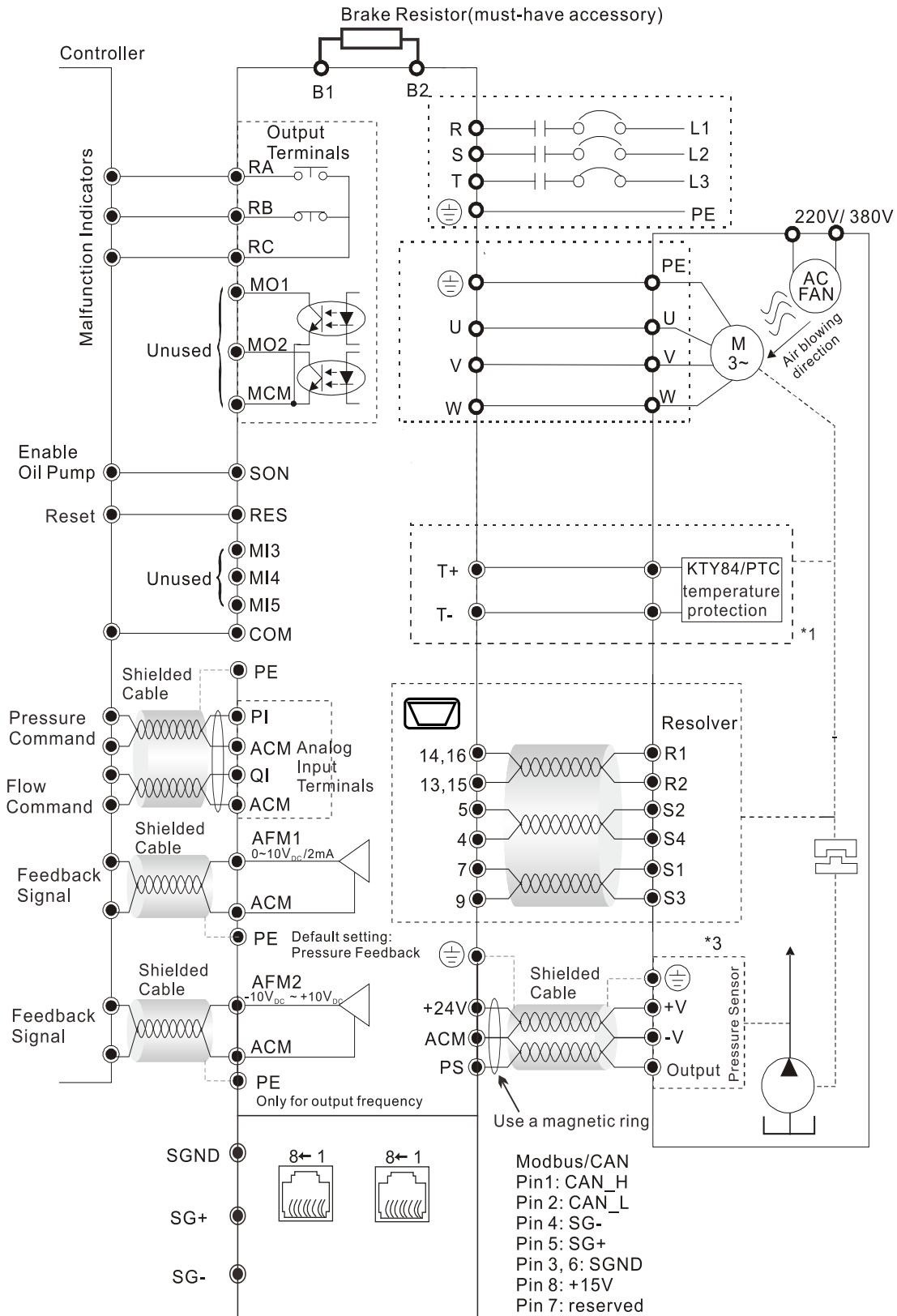

* The KTY84 temperature sensor is used; be ware of the polarities. The colors of the motor encoder wire CBHE-E5M are: black/white for KTY-, red/white for KTY+, yellow/black for PTC, and yellow for PTC.

Suggested Cooling System (Oil Cooled Type)

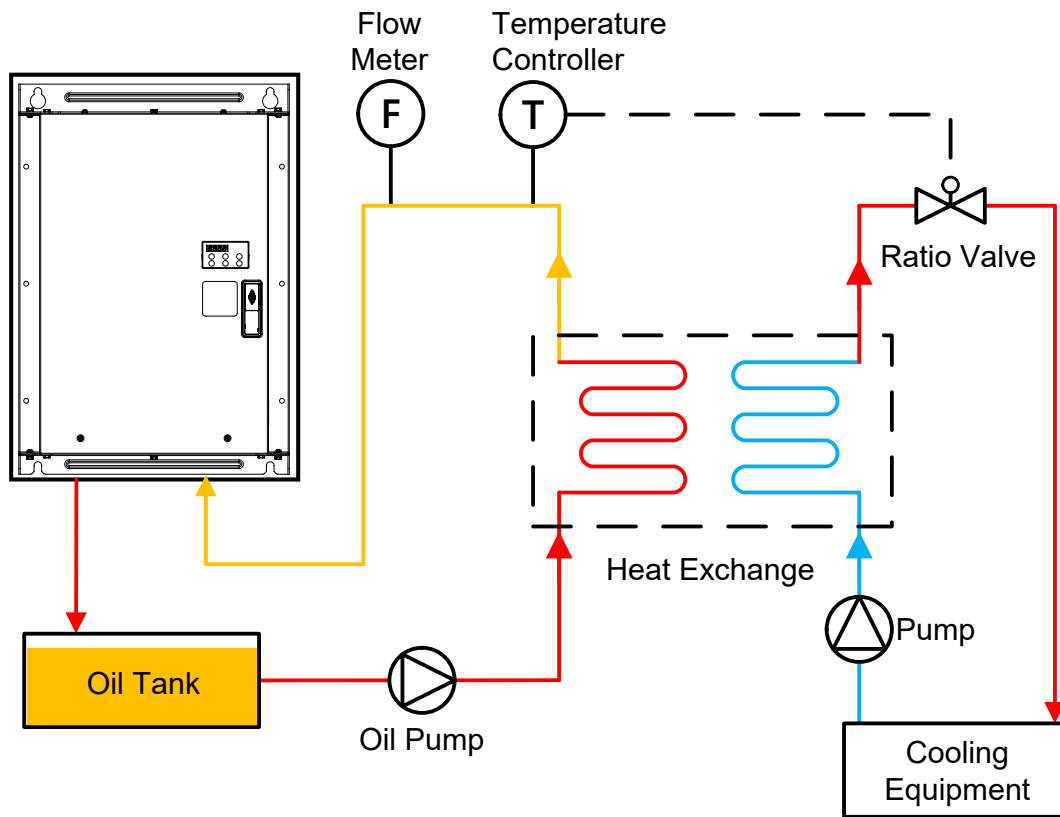

Installation (Oil Cooled Type)

Through-wall mount

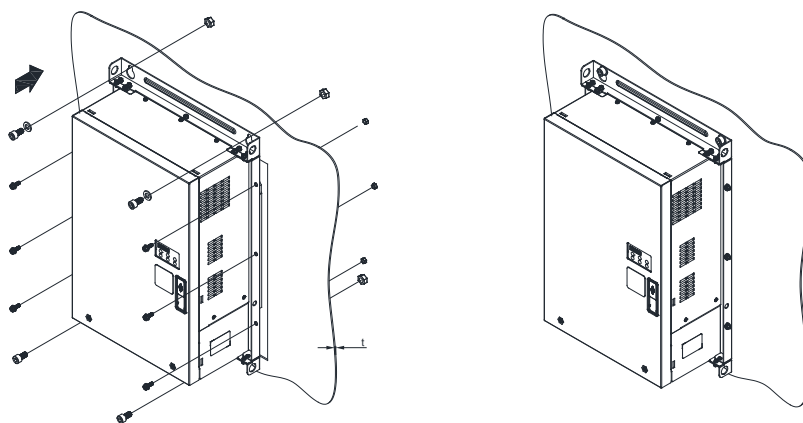

- You can install the drive through the wall and fix it with 4 pieces of M10 screw and 6 pieces of M6 screw with screw nuts
- Suggested length of M10 screw $L1 = \text{wall depth}(t) + 16\text{mm}$, torque: $200\text{kg}\cdot\text{cm}[173.4 \text{ lb}\cdot\text{in.}]$
- Suggested length of M6 screw $L2 = \text{wall depth}(t) + 12\text{mm}$, torque: $40\text{kg}\cdot\text{cm}[34.7 \text{ lb}\cdot\text{in.}]$

Dimensions

Frame C

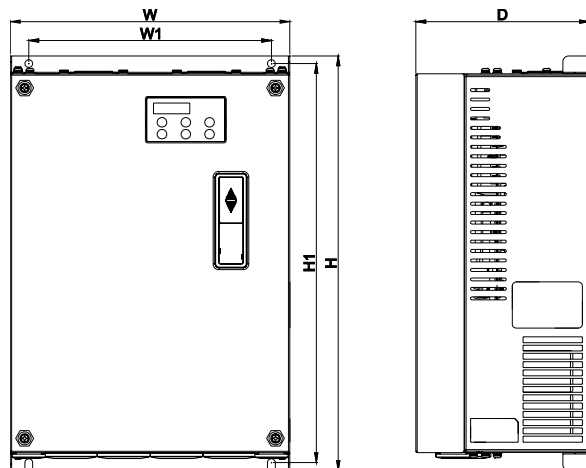

MODEL

VFD055VL23A / 43A-J
 VFD075VL23A / 43A-J
 VFD110VL23A / 43A / 43C-J
 VFD150VL43B / 43C-J
 VFD185VL43B / 43C-J
 VFD220VL43C-J

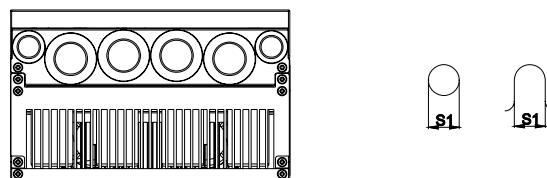

Unit: mm/inch

框號	W	W1	H	H1	H3	D	S1	$\phi 1$	$\phi 2$	$\phi 3$	
C	mm	235	204	350	337	-	146	6.5	-	34	22
	inch	9.25	8.03	13.78	13.27	-	5.35	0.26	-	1.34	0.87

Frame D

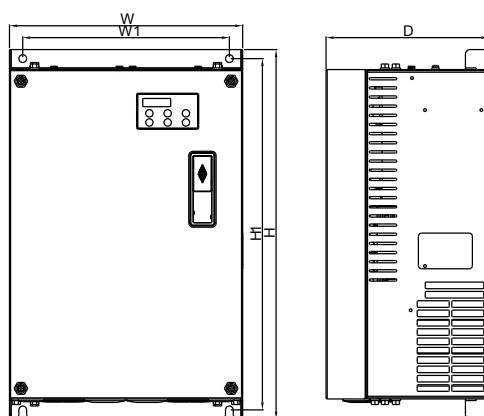

MODEL

VFD150VL23A-J
 VFD185VL23A-J
 VFD220VL23A / 43A-J
 VFD300VL43B / 43C-J
 VFD370VL43C-J

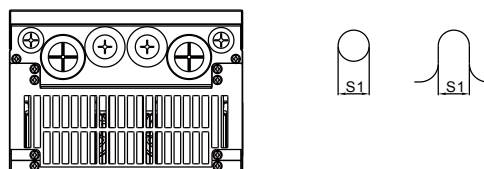

Unit: mm/inch

Frame	W	W1	H	H1	D	ϕ	$\phi 1$	$\phi 2$	$\phi 3$	
D	mm	255.0	226.0	403.8	384.0	178.0	8.5	44.0	34.0	22.0
	inch	10.04	8.90	15.90	15.12	6.61	0.33	1.73	1.34	0.87

Dimensions

Frame E0

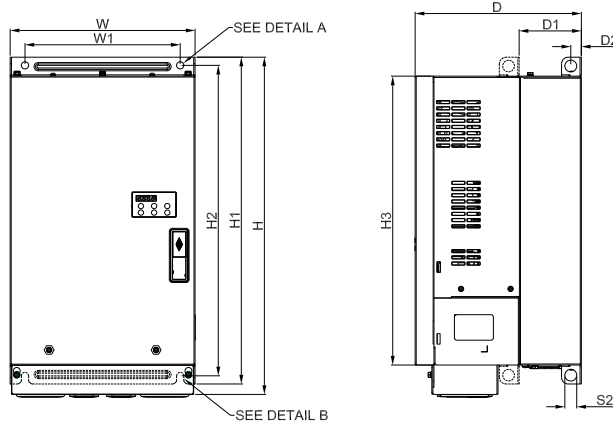

MODEL

VFD370VL43B-J

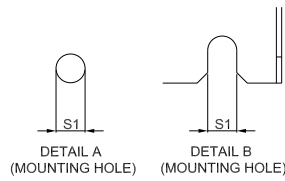
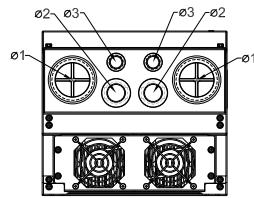

Frame E3

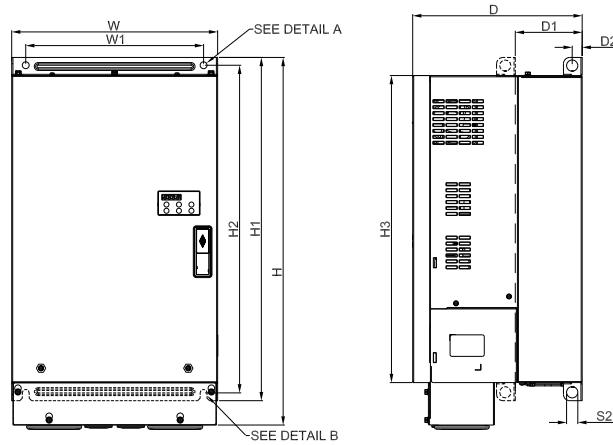

MODEL

VFD450VL43B-J

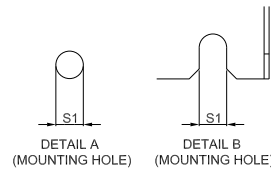
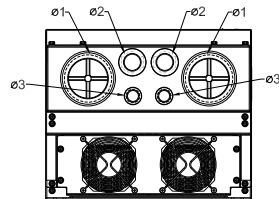

Unit: mm/inch

Frame		W	W1	H	H1	H2	H3	D	D1*	D2	S1	S2	Ø1	Ø2	Ø3
E0	mm	280.0	235.0	516.0	500.0	475.0	442.0	251.7	94.2	16.0	11.0	18.0	62.7	34.0	22.0
	inch	11.02	9.25	20.31	19.69	18.70	17.40	9.91	3.71	0.63	0.43	0.71	2.47	1.34	0.87
E3	mm	330.0	285.0	589.0	550.0	525.0	492.0	271.6	107.2	16.0	11.0	18.0	76.2	34.0	22.0
	inch	12.99	11.22	23.19	21.65	20.67	19.37	10.69	4.22	0.63	0.43	0.71	3.00	1.34	0.87

Dimensions

Frame E4

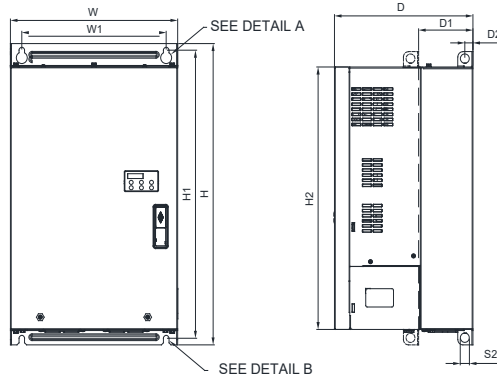

MODEL

VFD300VL23C-J
 VFD370VL23C-J
 VFD450VL43C-J
 VFD550VL43C-J
 VFD750VL43C-J

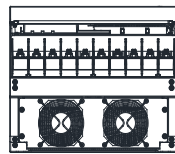

DETAIL A
(MOUNTING HOLE)



DETAIL B
(MOUNTING HOLE)

Unit: mm/inch

Frame	W	W1	H	H1	H2	D	D1*	D2	S1	S2	
E4	mm	330.0	285.0	565.0	540.0	492.0	273.4	107.2	16.0	11.0	18.0
	inch	12.99	11.22	22.24	20.67	19.37	10.76	4.22	0.63	0.43	0.71

Frame E5

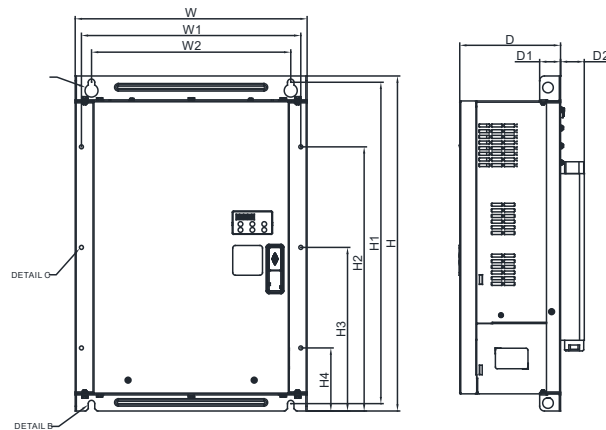

MODEL

VFD300VL43C-JO
 VFD370VL43C-JO
 VFD450VL43C-JO
 VFD550VL43C-JO
 VFD750VL43C-JO

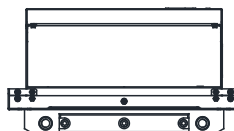

DETAIL A



DETAIL B



DETAIL C

Unit: mm/inch

Frame	W	W1	W2	H	H1	H2	H3	H4	D	D1	D2	S1	S2	
E5	mm	390.0	368.8	335.0	563.0	540.0	444.0	275.0	106.0	209.4	35.0	40.0	11.0	7.0
	inch	15.35	14.52	13.19	22.17	21.26	17.48	10.83	4.17	8.24	1.38	1.57	0.43	0.28

How to Select the Right Hybrid Energy System

(1) Motor Power Selection

$$T = \frac{q \cdot \Delta p}{2\pi \cdot \eta_m} \quad P = \frac{2\pi \cdot T \cdot N}{2\pi \cdot \eta_m} = \frac{T \cdot N}{9,550} = \frac{Q \cdot \Delta p}{60 \cdot \eta_t}$$

q: Displacement (cc/rev)	n: Rotation speed	Δp : Valid pressure difference (MPa)
Q: Required flow (L/min)	η_m : Pump mechanical efficiency	η_t : Pump total efficiency

(2) Solution for Signal Interference

When the drive is installed at the control panel, protect against signal interference as follows:

- The wirings of main circuit and control circuit must be separate
- Proper grounding is required
- Use shielding cable for the control circuit
- Use metal pipe for the main power cable for the main circuit wiring

(3) How to Choose a Suitable Hybrid Servo Drive and Motor

In the field application, the selection of hybrid servo drive and motor will be different due to different oil systems. In the following examples, a flow rate of 64L/min and a max. holding pressure of 17.5MPa are used.

- **Displacement of hydraulic pumps:** get the displacement of hydraulic pump (cc/rev) from max. system flow (L/min)
Example: Assume that max. system flow is 64L/min. and max. motor speed is 2000rpm, the displacement of hydraulic pump will be $64/2000 \times 1000 = 32\text{cc/rev}$
- **Max. motor torque:** get the max. torque from max. pressure and the displacement of hydraulic pump
Example: Assume that the max. pressure is 17.5MPa and the displacement of the hydraulic pump is 32cc/rev. The torque will be $17.5 \times 32 \times 1.3 / (2\pi) = 116\text{Nm}$ (the factor 1.3 is for compensation of total system losses and it can be changed to 1.2-1.3 as required)
- **Rated motor torque and rated motor power:** The required torque for the holding pressure at the max. pressure should be double the rated motor torque or less (use the data provided from the motor manufacturer as the first priority). Note that the motor temperature in this situation may easily overheat. Assuming that we choose double of rated torque, the motor can be 9.1kW* with the rated speed 1500rpm when the rated motor torque is 58N-m.
 * Motor Power Formula: $P(W) = T(N-m) \times \omega(\text{rpm} \times 2\pi / 60)$
- **Max. motor current:** If getting the torque constant k_t (Nm/A) = 3.31 in the motor specification, max. current is about $116 / 3.31 = 35\text{A}$ when the max. torque is 116N-m.
- **Select the right drive:** Please choose the right drive for the customers' requirement. Assume that the drive's overload is 150% for 60 seconds and 200% for 3 seconds. When the holding pressure is at max. pressure 17.5MPa with 32cc/rev hydraulic pump, the motor current it requires is 35A.

NOTE If none of the motors are suitable for your case, please choose motors with higher power range. Please contact Delta if you have any questions about the hybrid servo drive or integration with your current system.

- A. Using VFD075VL43A-J as an example: The rated current is 15.8A, and overload percentage is 220% ($35/15.8 \times 100\%$), and the system will shut down within 1 second.
- B. Using VFD110VL43A-J as an example: The rated current is 21A, and overload percentage is 166% ($35/21 \times 100\%$), and the system will shut down in 40~50 seconds.
- C. Using VFD150VL43A-J as an example: The rated current is 27A, and overload percentage is 130% ($35/27 \times 100\%$), and the system will shut down in 60 seconds.

(4) Select the Right Pressure Sensor

Optimum linearity with signal range 0~10V or 4~20mA.

(5) Select the Right Shaft Coupling

Select the shaft coupling diameter to match the motor shaft diameter with good alignment and no clearance. It is recommended that you choose a flexible coupling or a rigid coupling.

(6) Hydraulic Pumps

- Select the displacement for hydraulic pump that matches the required flow and motor speed
- If noise is the primary concern, a screw pump and an internal gear pump are both suitable for low-noise operation
- A piston pump fulfills the demand of high volumetric efficiency

• Commonly-used hydraulic pumps:

Hydraulic Pump Types	Volumetric Efficiency	Flow Pulsation	Speed	Noise
Internal Gear Pump	Low	Medium	Medium	Low
Piston Pump	High	Low	Low	High
Screw Pump	Medium	High	High	Medium

Accessories

(1) Brake Resistor (Compatibility List)

230V								
Compatible Model	125% Brake Torque 10% ED ^{*1}					Maximum Brake Torque		
Model Number	Brake Torque (kg-m)	Brake Unit	Compatible Brake Resistor Model ²	Brake Resistor Specification	Brake Current (A)	Minimum Resistor Limit (Ω)	Maximum Brake Current Limit (A)	Maximum Peak Power (kW)
		VFDB ³						
VFD055VL23A-J	3.7	-	BR1K0W020 x 1	1000W 20Ω	19	15.6	24.4	9.3
VFD075VL23A-J	5.1	-	BR1K5W013 x 1	1500W 13Ω	29	11.5	33.0	12.5
VFD110VL23A-J	7.4	-	BR1K5W013 x 1	1500W 13Ω	29	9.5	40.0	15.2
VFD150VL23A-J	10.2	-	BR1K0W4P3 x 2	2 SC 2000W 8.6Ω	44	8.3	46.0	17.5
VFD185VL23A-J	12.2	-	BR1K2W3P9 x 2	2 SC 2400W 7.8Ω	49	5.8	66.0	25.1
VFD220VL23A-J	14.9	-	BR1K5W3P3 x 2	2 SC 3000W 6.6Ω	58	5.8	66.0	25.1
VFD300VL23C-J	20.3	-	BR1K0W5P1 x 4	2 PC 2 SC 4000W 5.1Ω	75	4.8	80.0	30.4
VFD370VL23C-J	25.0	-	BR1K2W3P9 x 4	2 PC 2 SC 4800W 3.9Ω	97	3.2	120.0	45.6

460V								
Compatible Model	125% Brake Torque 10% ED ^{*1}					Maximum Brake Torque		
HP	Brake Torque (kg-m)	Brake Unit	Compatible Brake Resistor Model ²	Brake Resistor Specification	Brake Current (A)	Minimum Resistor Limit (Ω)	Maximum Brake Current Limit (A)	Maximum Peak Power (kW)
		VFDB ³						
VFD055VL43A-J	3.7	-	BR1K0W075 x 1	1000W 75Ω	10.2	48.4	15.7	11.9
VFD075VL43A-J	5.1	-	BR1K5W043 x 1	1500W 43Ω	17.6	39.4	19.3	14.7
VFD110VL43A-J	7.4	-	BR1K5W043 x 1	1500W 43Ω	17.6	30.8	24.7	18.8
VFD110VL43C-J	7.4	-	BR1K5W043 x 1	1500W 43Ω	17.6	30.8	24.7	18.8
VFD150VL43B-J VFD150VL43C-J	10.2	-	BR1K0W016 x 2	2 SC 2000W 32Ω	24	25.0	30.4	23.1
VFD185VL43B-J VFD185VL43C-J	12.2	-	BR1K5W013 x 2	2 SC 3000W 26Ω	29	20.8	36.5	27.7
VFD220VL43C-J	14.9	-	BR1K5W013 x 2	2 SC 3000W 26Ω	29	19.0	40.0	30.4
VFD300VL43B-J	20.3	-	BR1K0W016 x 4	2 PC 2 SC 4000W 16Ω	47.5	14.1	54.0	41.0
VFD300VL43C-J VFD300VL43C-JO			BR1K0W5P1 x 4	4 SC 4000W 20.4Ω	37	19	40.0	30.4
VFD370VL43B-J	25.0	4045 x 1	BR1K2W015 x 4	2 PC 2 SC 4800W 15Ω	50	12.7	60.0	45.6
VFD370VL43C-J		-				14.0	54.0	40.8
VFD370VL43C-JO		-				12.7	60.0	45.7
VFD450VL43B-J	30.5	4045 x 1	BR1K5W013 x 4	2 PC 2 SC 6000W 13Ω	59	12.7	60.0	45.7
VFD450VL43C-J		-						
VFD450VL43C-JO		-						
VFD550VL43C-J VFD550VL43C-JO	37.2	-	BR1K0W5P1 x 8	2 PC 4 SC 8000W 10.2Ω	76	9.5	80.0	60.8
VFD750VL43C-J VFD750VL43C-JO	50.8	-	BR1K2W015 x 8	4 PC 2 SC 9600W 7.5Ω	100	6.3	120.0	90.7

*1. 125% Brake Torque comes from (kw)*125%*0.8. Because of the resistor consuming power limit, the longest operation time of 10% ED is 10 seconds (on: 10 seconds / off: 90 seconds)

*2. Resistors below 400W need to be fixed on the shelf for cooling purposes, and the surface temperature needs to be below 250 °C. Resistors above 1000W need to keep the surface temperature at below 350 °C.

*3. Please refer to the user manual of VFD-VJ-B Brake Unit for more details.

*4. SC = Series Connection. PC = Parallel Connection.

Accessories

(2) VFD-VJ-B Brake Unit

Voltage Level		230V Series		460V Series		
Model VFDB- □□□□		2015	2022	4030	4045	4132
Max. Motor Capacity (kW)		15	22	30	45	132
Output Rating	Max. Discharge Current (I _{peak}) 10ED%	40	60	40	60	240
	Continuous Discharge Current (A)	15	20	15	18	75
	Braking Start-Up Voltage (DC)	330 / 345 / 360 / 380 / 400 / 415±3V		660 / 690 / 720 / 760 / 800 / 830±6V		618 / 642 / 667 / 690 / 725 / 750±6V
Input Rating	DC Voltage	200 ~ 400 VDC		400 ~ 800 VDC		480 ~ 750VDC
Protection	Heat Sink Overheat	Temperature over + 95 °C				
	Alarm Output	RELAY contact 5A 120VAC/28VDC (RA.RB.RC)				
	Power Charge Display	Blackout until bus (P-N) voltage is below 50 VDC				
Operating Environment	Installation Location	Indoor (no corrosive gases, metallic dust)				
	Operation Temperature	-10 °C ~ +50 °C				
	Storage Temperature	-20 °C ~ +60 °C				
	Humidity	90% RH Non-Condensing				
	Vibration	Below 20Hz 9.8m/S ² (1G) · 20 ~ 50Hz 2m/S ² (0.2G)				
Mechanical Configuration		Wall-mounted enclosed type IP50				

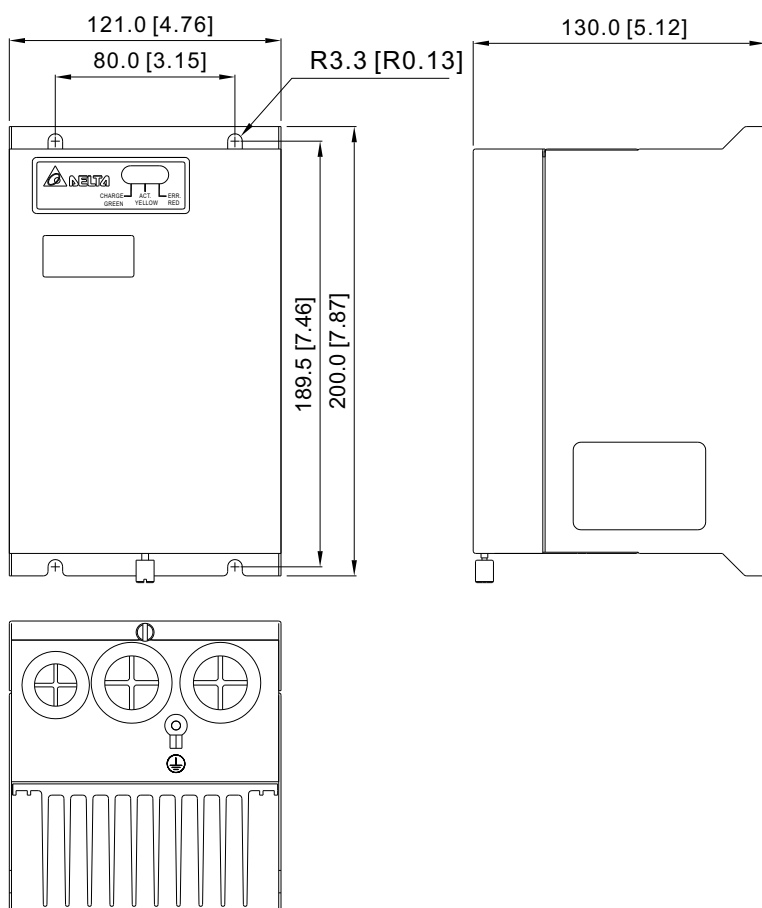

Accessories

(3) Reactor

	AC Input Reactor Specification												AC Output Reactor Specification																	
	460V, 50/60Hz, three-phase												230V, 50/60Hz, three-phase						460V, 50/60Hz, three-phase											
KW	5.5	7.5	11	15	18.5	22	30	37	45	55	75	5.5	7.5	11	15	18.5	22	30	37	5.5	7.5	11	15	18.5	22	30	37	45	55	75
HP	7.5	10	15	20	25	30	40	50	60	75	100	7.5	10	15	20	25	30	40	50	7.5	10	15	20	25	30	40	50	60	75	100
Fundamental Amps	12	18	25	35	35	45	55	80	80	100	130	25	35	55	80	80	100	130	160	18	18	25	35	45	45	80	80	100	130	160
Max. Continuous Amps	18	27	37.5	52.5	52.5	67.5	82.5	120	120	150	195	37.5	52.5	82.5	120	120	150	195	240	27	27	37.5	52.5	67.5	67.5	120	120	150	195	240
Inductance (mh)																														
	3% Impedance	2.5	1.5	1.2	0.8	0.8	0.7	0.5	0.4	0.4	0.3	0.2	0.5	0.4	0.25	0.2	0.2	0.15	0.1	0.075	1.5	1.5	1.2	0.8	0.7	0.7	0.4	0.4	0.3	0.2
5% Impedance	4.2	2.5	2	1.2	1.2	1.2	0.85	0.7	0.7	0.45	0.3	1.2	0.8	0.5	0.4	0.4	0.3	0.2	0.15	2.5	2.5	2	1.2	1.2	1.2	0.7	0.7	0.45	0.3	0.23

(4) Pulse Generator PG Card (VFD-VJ-A / VFD-VJ-B Series)



EMVJ-PG02R	Resolver Generator Card
EMVJ-PG01U	Linedriver (ABZ+UVW)

(5) Communication Card (VFD-VJ-A / VFD-VJ-B Series)



EMVJ-MF01

Terminal	Descriptions
⊕	Ground
SG- SG+	RS-485 connections
GND	Signal terminal

Accessories

(6) EMC Filter

	230V 3-phase Model	Filter Model Name	Motor Cable Length(m)
230V	VFD055VL23A-J	KMF336A	50
	VFD075VL23A-J	KMF336A	50
	VFD110VL23A-J	KMF350A	50
	VFD150VL23A-J	KMF370A	50
	VFD185VL23A-J	KMF3100A	50
	VFD220VL23A-J	KMF3100A	50
460V	VFD055VL43A-J	KMF318A	50
	VFD075VL43A-J	KMF325A	50
	VFD110VL43A-J	KMF325A	50
	VFD150VL43B-J	KMF336A	50
	VFD185VL43B-J	KMF350A	50
	VFD220VL43A-J	KMF350A	50
	VFD300VL43B-J	KMF370A	50
	VFD370VL43B-J	KMF370A	50
	VFD450VL43B-J	KMF3100A	50
	Fan-cooled Type	VFD110VL43C-J	B84143A0050R106
VFD150VL43C-J		B84143A0050R106	50
VFD185VL43C-J		B84143A0050R106	50
VFD220VL43C-J		B84143A0050R106	50
VFD300VL43C-J		B84143A0100R106	50
VFD370VL43C-J		B84143A0100R106	50
VFD450VL43C-J		B84143D0200R127	50
VFD550VL43C-J		B84143D0200R127	50
VFD750VL43C-J		B84143D0200R127	50
Oil-cooled Type		VFD300VL23C-J	B84143D0200R127
	VFD370VL23C-J	B84143D0200R127	50
	VFD300VL43C-JO	B84143D0200R127	50
	VFD370VL43C-JO	B84143D0200R127	50
	VFD450VL43C-JO	B84143D0200R127	50
VFD550VL43C-JO	B84143D0200R127	50	
VFD750VL43C-JO	B84143D0200R127	50	



(7) Zero Phase Reactor

RF220X00A

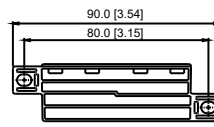
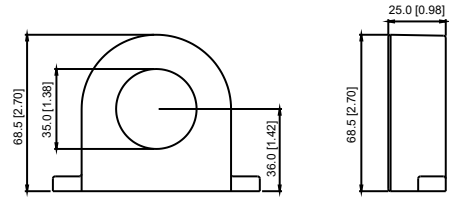

(9) USB Connection Interface

IFD6530 RS485-to-USB converter



(10) Digital Keypad

KPV-CE01

KPC-CC01



(8) Magnetic Ring & Clip:

Magnetic Ring (Model: DMC684413A)

Clip (Model: CTC230836C)



*KPV-CE01 only applicable for VFD-VJ-A/B

*KPV-CC01 only applicable for VFD-VJ-C

Servo Motor

Fan Cooled Type

Frame 200 X 200

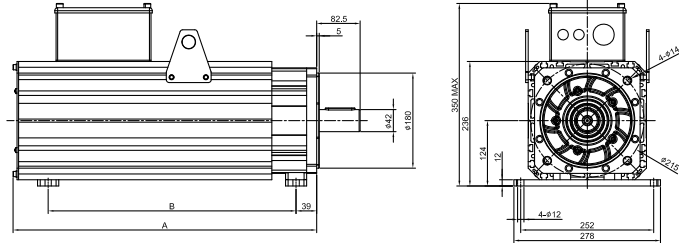

Frame 264 X 264

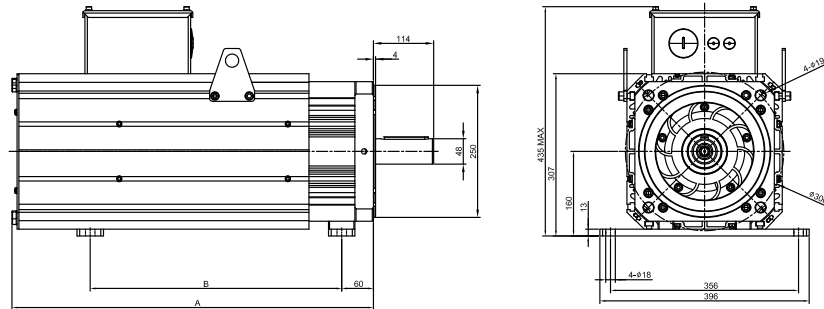

Motor Specifications

Model MSJ-__C	IR2070E42	IR201AE42	IR201EE42	IR201IE42	OR202DE42	LR202FE42	IR202HE42	IR203CE42	OR264FE48	IR265CE48	IR266IE48	
Frame (mm)	200 x 200								264 x 264			
Voltage	380V											
Rated Output Power (kW)	7	10	14	18	23	25	27	32	45	52	68	
No. of Poles	8											
Rated Torque (N-m)	40	58	83	103	120	159	153	180	240	295	385	
Maximum Torque (N-m)	80	112	155	208	215	336	300	320	432	531	695	
Rated Speed (r/min)	1700	1700	1700	1700	1800	1500	1700	1700	1800	1700	1700	
Maximum Speed (r/min)	2150	2150	2150	2150	2250	1950	2150	2150	2250	2150	1950	
Rated Current (A)	15.9	23	32.8	42.1	46.7	55.9	54.2	70	96.5	115	149	
Torque Constant (N-m/A)	2.52	2.52	2.53	2.45	2.57	2.85	2.82	2.6	2.49	2.57	2.58	
Voltage Constant (V / krpm)	173	171	171	180	171	192	192	177	175	182	170	
Phase Resistance (Ohm)	1.232	0.673	0.396	0.319	0.271	0.232	0.232	0.148	0.088	0.074	0.047	
Inductance (mH)	15.518	8.584	6.218	4.663	3.995	3.636	3.636	2.740	2.385	2.305	1.721	
Rotor Moment of Inertia (kg-cm ²)	48.5	74	96	116	138	180	180	191	416	505	614	
Weight (kg)	39.5	46	53	59.5	67.5	83.6	83.6	85	134	152	171	
Dimension A (mm)	345	381	417	453	489	575	575	590	577	631	684	
Dimension B (mm)	265	285	310	350	395	470	470	470	370	423	476	
Insulation Class	Class F (Winding Class H)											
Protection Class	IP54											
Efficiency Class	IE3 / GB30253-2013											
Cooling Method	Forced air cooling AC Fan 220VAC											
Encoder Type	Resolver 2 Poles											
Motor Temperature Protection	PTC130 thermistor and KTY84-130 temperature sensor											
Operating Environment	Temperature -15 ~ 40°C Humidity 20 ~ 90% RH (non condensing) Altitude <1000m											
Installation Method	Flange / Foot											
Certifications	CE											

*1: This chart states the maximum operation speed of a motor with no field-weakening control. If field-weakening control is applied, the maximum operation speed of a motor is 2500rpm.
 *2: Users are required to set the parameter Pr.02-11 and Pr.02-09 Temperature Alarm (default 130 °C) when you use the KTY84-130 temperature sensor for motor overheating protection.
 *3: Users are required to set the parameter Pr.02-11=2 when you use the PTC130 thermistor for motor overheating protection.
 *4: Encoder cable (CBHE-E5M, 5m) is included in the motor package.
 *5: Delta reserves the right to use revised specifications without prior notice.

Servo Motor

Fan Cooled Type

Frame 200 X 200

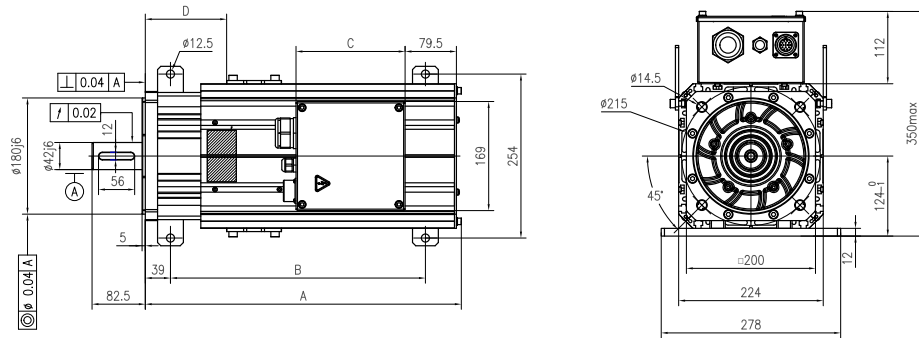

Model MSJ-__E	IR2075E42	IR201BE42	IR201FE42	IR201IE42	IR202CE42	IR202GE42	IR203AE42	
A mm	345	381	417	453	489	525	575	
B* mm	265	285	310	350	395	430	470	
C mm	169							240
D mm	95	110	130	150	160	180	200	

*B: The dimensions of the model MSJ-BE can be customized.

Motor Specifications

Model MSJ-__E		IR2075E42	IR201BE42	IR201FE42	IR201IE42	IR202CE42	IR202GE42	IR203AE42
Frame	mm	200 x 200						
Voltage	V	380V						
High Power Rating*1	kW	7.5	11	15	18.5	22	26	30
Power @$\Delta T=100^{\circ}C$	kW	9.5	15	18.5	22	26	29.5	36
No. of Poles		8						
Rated Torque*1	Nm	42.1	61.8	84.3	104	124	146	169
Maximum Torque*2	Nm	84.2	123.6	168.6	208	248	292	338
Rated Speed	rpm	1700						
Maximum Speed *3	rpm	2500						
Rated Current *1	A	13.9	20.3	27.5	35.5	40.5	49.5	56.3
Torque Constant *1	Nm/A	3.03	3.04	3.06	2.93	3.06	2.95	3.00
Voltage Constant	V/krpm	187	187	187	182	187	182	187
Phase Resistance	ohm	1.073	0.621	0.385	0.281	0.223	0.178	0.158
Rotor Moment of Inertia	kg-cm ²	62	87	112	137	160	187	213
Weight	kg	39.5	46	53	59.5	67.5	74	83.6
Insulation Class		Class F (Winding Class H)						
Protection Class		IP54						
Efficiency Class		IE4 / GB30253-2013						
Cooling Method		Forced fan cooled AC Fan 220VAC						
Encoder Type		Resolver 2 Poles						
Motor Temperature Protection		PTC130 thermistor and KTY84-130 temperature sensor						
Operating Environment		Temperature -15 ~ 40 °C · Humidity 20 ~ 90% RH (non condensing) · Altitude <1000 m						
Installation Method		Flange) / Support legs						
Certifications		CE						

*1: High efficiency operating point with stable status and less temperature rise (< 80° C) than the Chinese standard (100° C). Strict and stable thermal states are required for electric current and effectiveness.

*2: Periodical torque overloads at 1700 rpm: Twice larger than the rated power at the maximum. The actual maximum torque depends on operations; 250% is the practical maximum but last only for a short period of time. Please refer to the overload chart of T-N Curves.

*3: The actual maximum speed depends on motor field-weakening control. 2500 rpm is a suggested value, not a limit.

Servo Motor

Oil Cooled Type

Frame 200 X 200

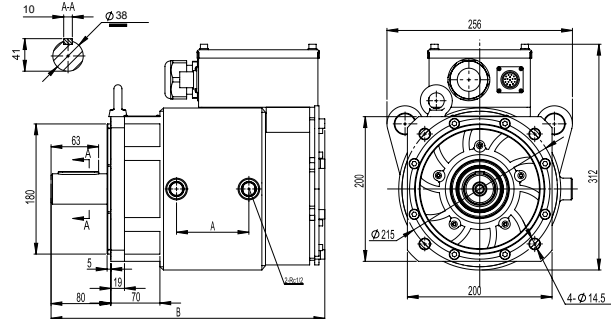

Frame 264 X 264

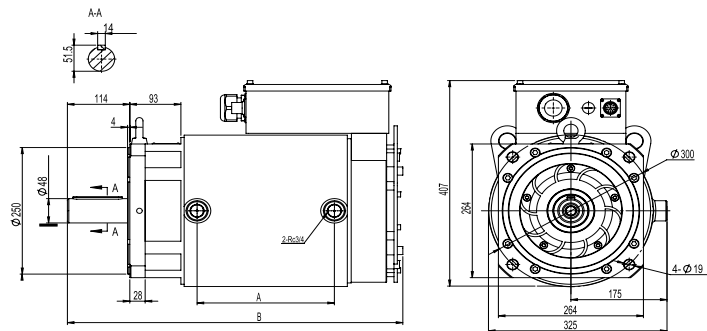

Model MSO__C	IR203AE42	IR263HE48	IR264HE48	IR265JE48	IR266IE48
Frame (mm)	200 x 200	264 x 264			
Voltage	380V				
Rated Output Power (kW)	30	37	47	59	68
No. of Poles	8				
Rated Torque (N-m)	170	210	266	333	385
Maximum Torque (N-m)	320	336	426	533	695
Rated Speed (r/min)	1700				
Maximum Speed (r/min)	2150				
Rated Current (A)	70.5	85	102	127	149
Torque Constant (N-m/A)	2.41	2.47	2.60	2.62	2.58
Voltage Constant (V/krpm)	179	183	190	186	190
Phase Resistance (Ohm)	0.143	0.110	0.077	0.054	0.047
Inductance (mH)	2.33	3.50	2.66	1.95	1.72
Rotor Moment of Inertia (kg-m ²)	180	326	416	505	588
Weight (kg)	98	126.5	145	167.5	190
Dimension A (mm)	292	143	197	250	304
Dimension B (mm)	573	503	557	610	664
Insulation Class	Class F (Winding Class H)				
Protection Class	IP54				
Efficiency Class	IE3 / GB30253-2013				
Cooling Method	Forced air cooling AC Fan 220VAC				
Encoder Type	Resolver 2 Poles				
Motor Temperature Protection	PTC130 thermistor and KTY84-130 temperature sensor ^{*2}				
Operating Environment	Temperature -15~40°C Humidity 20~90% RH (non condensing) Altitude <1000m				
Installation Method	Flange				
Certifications	CE				

*1: This chart states the maximum operation speed of a motor with no field-weakening control. If field-weakening control is applied, the maximum operation speed of the motor is 2500rpm.
 *2: Users are required to set the parameter Pr.02-11 and Pr.02-09 Temperature Alarm (default 130 °C) when you use the KTY84-130 temperature sensor for motor overheating protection.
 *3: Users are required to set the parameter Pr.02-11=2 when you use the PTC130 thermistor for motor overheating protection.
 *4: Encoder cable (CBHE-E5M, 5m) is included in the motor package.
 *5: Delta reserves the right to use revised specifications without prior notice.

Hybrid Electric Solution for Injection Molding Machines

Delta presents the Hybrid Electric Solution for Injection Molding Machines. The solution adopts the Control Unit for Injection Machine CSJ Series as controller, and connects the Hybrid Energy Saving System, Direct-drive Torque Motor MST Series, and Door Control Drive DD Series via communication. The integrated solution simplifies the system structure. The production data can be monitored and managed on Delta MES System for the Injection Machine DIAeBox.

Features

- Connects the master controller, servo drive and motor via CANopen for real-time communication
- Exclusive user interface for the HES system control & monitoring and parameters adjustment
 - Obtains the optimized parameters for different actions of the hydraulic drive system
 - Seamless integration with Delta drives
 - Component lifetime alarm and maintenance notice
 - Enhancement of Overall Equipment Effectiveness (OEE)
- Delta equipment integration and one-stop after-sales service
- Remote VPN monitoring with a messaging software for real-time trouble shooting
- Supports standard Ethernet communication to connect peripheral equipment and achieve equipment IoT

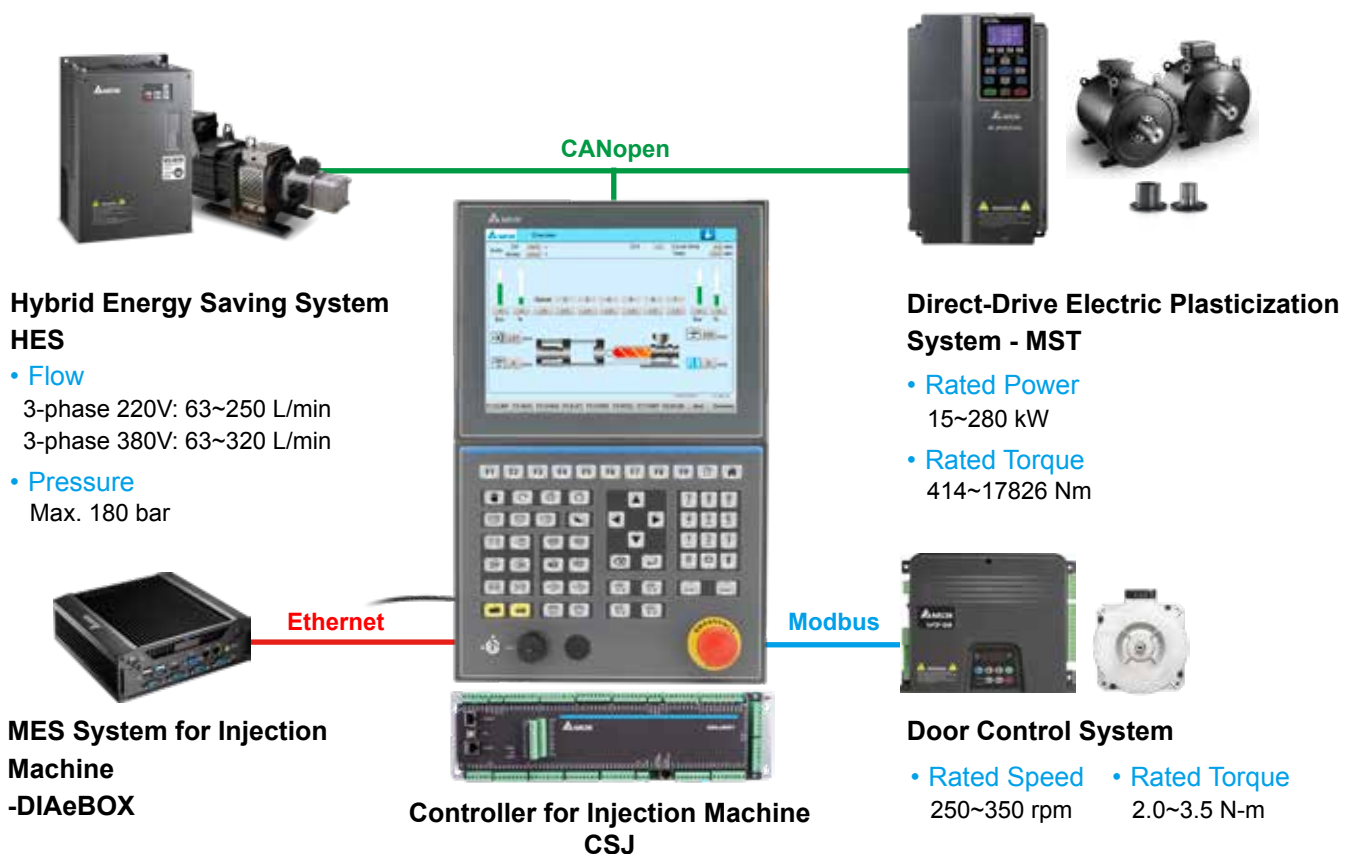

* Delta reserves the right to modify specifications without prior notice.



Smarter. Greener. Together.

Industrial Automation Headquarters

Taiwan: Delta Electronics, Inc.

Taoyuan Technology Center
No.18, Xinglong Rd., Taoyuan District,
Taoyuan City 33068, Taiwan
TEL: +886-3-362-6301 / FAX: +886-3-371-6301

Asia

China: Delta Electronics (Shanghai) Co., Ltd.

No.182 Minyu Rd., Pudong Shanghai, P.R.C.
Post code : 201209
TEL: +86-21-6872-3988 / FAX: +86-21-6872-3996
Customer Service: 400-820-9595

Japan: Delta Electronics (Japan), Inc.

Industrial Automation Sales Department
2-1-14 Shibadaimon, Minato-ku
Tokyo, Japan 105-0012
TEL: +81-3-5733-1155 / FAX: +81-3-5733-1255

Korea: Delta Electronics (Korea), Inc.

1511, 219, Gasan Digital 1-Ro., Geumcheon-gu,
Seoul, 08501 South Korea
TEL: +82-2-515-5305 / FAX: +82-2-515-5302

Singapore: Delta Energy Systems (Singapore) Pte Ltd.

4 Kaki Bukit Avenue 1, #05-04, Singapore 417939
TEL: +65-6747-5155 / FAX: +65-6744-9228

India: Delta Electronics (India) Pvt. Ltd.

Plot No.43, Sector 35, HSIIDC Gurgaon,
PIN 122001, Haryana, India
TEL: +91-124-4874900 / FAX: +91-124-4874945

Thailand: Delta Electronics (Thailand) PCL.

909 Soi 9, Moo 4, Bangpoo Industrial Estate (E.P.Z),
Pattana 1 Rd., T.Phraksa, A.Muang,
Samutprakarn 10280, Thailand
TEL: +66-2709-2800 / FAX: +66-2709-2827

Australia: Delta Electronics (Australia) Pty Ltd.

Unit 20-21/45 Normanby Rd., Notting Hill Vic 3168, Australia
TEL: +61-3-9543-3720

Americas

USA: Delta Electronics (Americas) Ltd.

5101 Davis Drive, Research Triangle Park, NC 27709, U.S.A.
TEL: +1-919-767-3813 / FAX: +1-919-767-3969

Brazil: Delta Electronics Brazil

Rua Itapeva, 26 - 3º, andar Edifício Itapeva,
One - Bela Vista 01332-000 - São Paulo - SP - Brazil
TEL: +55-12-3932-2300 / FAX: +55-12-3932-237

Mexico: Delta Electronics International Mexico S.A. de C.V.

Gustavo Baz No. 309 Edificio E PB 103
Colonia La Loma, CP 54060
Tlalnepantla, Estado de México
TEL: +52-55-3603-9200

EMEA

EMEA Headquarters: Delta Electronics (Netherlands) B.V.

Sales: Sales.IA.EMEA@deltaww.com
Marketing: Marketing.IA.EMEA@deltaww.com
Technical Support: iatechnicalsupport@deltaww.com
Customer Support: Customer-Support@deltaww.com
Service: Service.IA.emea@deltaww.com
TEL: +31(0)40 800 3900

BENELUX: Delta Electronics (Netherlands) B.V.

Automotive Campus 260, 5708 JZ Helmond, The Netherlands
Mail: Sales.IA.Benelux@deltaww.com
TEL: +31(0)40 800 3900

DACH: Delta Electronics (Netherlands) B.V.

Coesterweg 45, D-59494 Soest, Germany
Mail: Sales.IA.DACH@deltaww.com
TEL: +49(0)2921 987 0

France: Delta Electronics (France) S.A.

ZI du bois Challand 2, 15 rue des Pyrénées,
Lisses, 91090 Evry Cedex, France
Mail: Sales.IA.FR@deltaww.com
TEL: +33(0)1 69 77 82 60

Iberia: Delta Electronics Solutions (Spain) S.L.U

Ctra. De Villaverde a Vallecas, 265 1º Dcha Ed.
Hormigueras – P.I. de Vallecas 28031 Madrid
TEL: +34(0)91 223 74 20

Carrer Llacuna 166, 08018 Barcelona, Spain

Mail: Sales.IA.Iberia@deltaww.com

Italy: Delta Electronics (Italy) S.r.l.

Via Meda 2-22060 Novedrate(CO)
Piazza Grazioli 18 00186 Roma Italy
Mail: Sales.IA.Italy@deltaww.com
TEL: +39 039 8900365

Russia: Delta Energy System LLC

Vereyskaya Plaza II, office 112 Vereyskaya str.
17 121357 Moscow Russia
Mail: Sales.IA.RU@deltaww.com
TEL: +7 495 644 3240

Turkey: Delta Greentech Elektronik San. Ltd. Sti. (Turkey)

Şerifali Mah. Hendem Cad. Kule Sok. No:16-A
34775 Ümraniye – İstanbul
Mail: Sales.IA.Turkey@deltaww.com
TEL: + 90 216 499 9910

MEA: Eltek Dubai (Eltek MEA DMCC)

OFFICE 2504, 25th Floor, Saba Tower 1,
Jumeirah Lakes Towers, Dubai, UAE
Mail: Sales.IA.MEA@deltaww.com
TEL: +971(0)4 2690148