

Thank you for your purchase of the high performance Delta Machine Vision DMV1000 from Delta Electronics Inc. This operating manual describes components, installation, operation, troubleshooting, peripherals, and maintenance.

To guarantee proper installation and operation of the system, read this operating manual carefully and keep it safe for future reference.

Precautions

1. Check the signal connections, such as input voltage and polarity, before powering on to prevent damages due to an incorrect voltage input level.
2. Check that system power is turned off before inspecting the input power source or connecting the wires. Do not touch the terminals or connect the wires while system power is turned on to prevent electric shock.
3. Do not disassemble or modify the internal components of the controller.
4. The controller unit is an open-type chassis and must be installed in a panel box to protect it from dust, water, moisture, electric shock, and external impact.
5. Keep the controller away from metal scraps that may interfere with operation or cause damage to the components.
6. Keep the controller away from interference sources such as high voltage and high frequency noise during installation. Do not operate the system under the following conditions:
 - (a) Excessive dust or corrosive gasses
 - (b) High temperature, high humidity, and high levels of radiation
 - (c) External shock and impact
 - (d) Direct sunlight
7. Use a dry cloth to clean the system. Do not use cleaning solutions containing acidic or alkaline chemicals.
8. Check the ground terminal to the power source for proper connection. Check the terminals for secure connections.
9. Only use a blower to remove dust from the camera sensor or lens. Do not blow using your mouth to avoid getting moisture on the components.
10. Gently wipe off the lens only with a lens cloth. The lens may be scratched if you use excessive force or an inappropriate material.

DMV1000 Technical Manual

Table of Contents V2.0

Chapter 1 Components and Specifications

1.1 Packaging and Optional Parts:	1-1
1.1.1 Controller Packaging:.....	1-1
1.1.2 Camera (optional second camera):.....	1-1
1.1.3 Lens (optional):.....	1-1
1.1.4 LED Light Source (optional):.....	1-2
1.2 Controller unit and Keypad:	1-3
1.2.1 Specifications:	1-3
1.3 Camera and Lens:	1-5

Chapter 2 Input and Output Interface

2.1 I/O Terminal Block	2-1
2.1.1 9 pin input terminal	2-2
2.1.2 9 pin output terminal	2-3
2.1.3 50 pin I/O mixed terminal	2-4
2.2 Grounding and Installation:	2-5
2.2.1 Grounding:.....	2-5
2.2.2 Installation:	2-5

Chapter 3 Basic Operation

3.1 Keypad:	3-1
3.1.1 What is the ROI (Region of Interest):	3-1
3.2 Draw ROI (Region of Interest):	3-2
3.2.1 Draw a Rectangle:	3-2
3.2.2 Draw a Circle:	3-2
3.2.3 Draw a Polygon:	3-3
3.2.4 Draw an Ellipse:.....	3-4
3.2.5 Draw a Ring:.....	3-4
3.2.6 Draw an Arc:.....	3-5
3.2.7 Draw a Rotation Rectangle:	3-6
3.3 ROI (Region of Interest) Zoom:	3-7
3.3.1 What is Zoom:	3-7
3.3.2 Zoom Instructions:	3-7

Chapter 4 Set Up the Inspection Process

4.1 [Project list]:	4-2
4.1.1 What is a project	4-2
4.1.2 Project setup (add project)	4-2
4.2 [Program] Settings:	4-4
4.2.1 What is a [Program]:	4-4
4.2.2 [Program] Setup	4-4
4.2.3 [Camera] setup	4-4
4.2.4 [Image] Settings:	4-8
4.2.5 [Detection Window] settings:	4-10
4.2.6 [Calculator] settings:	4-11
4.2.7 [Judgment] settings:	4-13
4.2.8 [Output]	4-14

Chapter 5 System Setup

5.1 [Tools] Set:	5-2
5.2 [Communication] Set:	5-2
5.3 [Security] Set:	5-4
5.4 [Display] Set:	5-5
5.5 [Global] Set:	5-6
5.6 [Information]:	5-6

Chapter 6 Inspection Setting

6.1 Window Functionality:	6-1
6.1.1 Types of Inspection Windows	6-1
6.2 Area:	6-2
6.2.1 What defines the [Area]	6-2
6.2.2 Detection Result	6-2
6.2.3 Example Application of [Area]	6-3
6.2.4 Set up [Area] settings	6-4
6.3 Position:	6-8
6.3.1 What is [Position]	6-8
6.3.2 Detection Result	6-8
6.3.3 Example application of [Position]	6-9
6.3.4 Setup [Position]	6-10
6.4 Count:	6-14
6.4.1 What is [Count]	6-14
6.4.2 Detection Result	6-14
6.4.3 Example application of [Count]	6-15

6.4.4 Setup [Count].....	6-16
6.5 Width:.....	6-20
6.5.1 What is [Width]	6-20
6.5.2 Detection Result	6-20
6.5.3 Example application of [Width].....	6-21
6.5.4 Set up [Width] Detection	6-22
6.6 Pitch:.....	6-26
6.6.1 What is [Pitch].....	6-26
6.6.2 Detection Result	6-26
6.6.3 Example application of [Pitch].....	6-27
6.6.4 Setup [Pitch]	6-28
6.7 Angle:.....	6-32
6.7.1 What is [Angle]	6-32
6.7.2 Detection Result	6-32
6.7.3 Example application of [Angle].....	6-33
6.7.4 Set up [Angle] Detection	6-34
6.8 Pattern Comparison:.....	6-38
6.8.1 What is [Pattern Comparison]	6-38
6.8.2 Detection Result	6-38
6.8.3 Example application of [Pattern Comparison]	6-39
6.8.4 [Pattern Comparison] Detection Settings	6-40
6.9 Shape:.....	6-44
6.9.1 What is [Shape]	6-44
6.9.2 Detection Result	6-44
6.9.3 Example application of [Shape].....	6-45
6.9.4 Set up [Shape] Detection Settings	6-46
6.10 Blob:.....	6-50
6.10.1 What is [Blob]	6-50
6.10.2 Detection Result	6-50
6.10.3 Example application of [Blob].....	6-51
6.10.4 Set up [Blob] Detection Settings	6-52
6.11 Intensity:.....	6-56
6.11.1 What is [Intensity]	6-56
6.11.2 Detection Result	6-56
6.11.3 Example application of [Intensity].....	6-57
6.11.4 Set up [Intensity] Detection Settings	6-58
6.12 Position Trace:	6-62
6.12.1 What is [Position Trace].....	6-62
6.12.2 Detection Result	6-62
6.12.3 Example application of [Position Trace]	6-63

6.12.4 Set up [Position Trace] Detection Settings	6-64
6.13 Width Trace:	6-67
6.13.1 What is [Width Trace].....	6-67
6.13.2 Detection Result.....	6-67
6.13.3 Example application of [Width Trace].....	6-68
6.13.4 Set up [Width Trace] Detection Settings.....	6-69
6.14 Mark:	6-72
6.14.1 What is [Mark].....	6-72
6.14.2 Example application of [Mark]	6-72
6.14.3 Application Setting of [Mark].....	6-73
6.15 Smear Detection:	6-75
6.15.1 What is [Smear Detection].....	6-75
6.15.2 Detection Result.....	6-75
6.15.3 [Smear Detection] Application Example	6-76
6.15.4 [Smear Detection] Settings.....	6-77
6.16 OCV	6-80
6.16.1 What is [OCV]	6-80
6.16.2 Detection Result.....	6-80
6.16.3 [OCV] Application Example	6-81
6.16.4 [OCV] Settings	6-82
6.17 Classification:	6-90
6.17.1 What is [Classification]	6-90
6.17.2 Detection Result.....	6-90
6.17.3 [Character Recognition] Application Example.....	6-91
6.17.4 [Character Recognition] Settings.....	6-92
6.18 Code Reader:	6-94
6.18.1 What is [Code Reader].....	6-94
6.18.2 Detection Result.....	6-95
6.18.3 [Code Reader] Application Example.....	6-95
6.18.4 [Code Reader] Detection setting	6-96

Chapter 7 Calculator, Judge, and Output

7.1 What is [Calculator]:	7-1
7.2 Edit [Calculator]:	7-2
7.2.1 [Calculator] interface	7-2
7.2.2 [Calculator] function list:	7-6
7.3 What is [Judge]:	7-15
7.4 Edit [Judge]:	7-15
7.4.1 [Judge] interface	7-15
7.4.2 [Judge] Window Functions	7-17

7.5 What is [Output]:	7-19
7.6 Edit [Output]:	7-19
7.6.1 Setup [Output]	7-19
7.6.2 Setup [Image output]	7-21
7.6.3 Setup [Status]:	7-22

Chapter 8 I/O Timing

8.1 I/O Timing:	8-2
8.1.1 TRIG (Trigger capture):.....	8-2
8.1.2 Double buffering TRIG (Trigger) capture:.....	8-5
8.1.3 FLASH timer output:	8-10
8.1.4 Output result:	8-12
8.1.5 Result output time:.....	8-16
8.1.6 (Buffer) Image Save:.....	8-17
8.1.7 Function switch: FNC1–4, IN1–8, FRDY, FCH, SW, NSW	8-18
8.1.8 Other: TROFF, TEST, PLINK, RESET	8-22

Chapter 9 Serial Communication

9.1 RS232:	9-1
9.2 Result output mode:	9-2
9.3 PLC-LINK mode:	9-3
9.4 Slave mode:	9-4
9.4.1 Slave mode command table: (DMV communication format).....	9-4
9.4.2 Slave mode commands (DMV communication format).....	9-6
9.4.3 Slave mode command table: (Modbus communication format)	9-15
9.5 RS232 pin definition:	9-29
9.6 ASCII Table:	9-30
9.7 Communication formatting:	9-31
9.7.1 Delta HMI (DOP) data conversion:.....	9-31
9.7.2 Delta PLC (DVP) data conversion:.....	9-33

Chapter 10 Ethernet Communication Commands

10.1 Ethernet Communication Method	10-1
10.2 Description of MODBUS TCP Communication Method	10-1
10.3 MODBUS TCP Communication Commands	10-2
10.4 Ethernet Communication Example	10-2
10.4.1 DMV1000.....	10-8
10.4.2 Delta HMI (DOP).....	10-8
10.4.3 Delta PLC (AS)	10-10

Chapter 11 Appendix

11.1 Pre-processing:	11-1
11.1.1 What is Pre-processing	11-1
11.1.2 Pre-processing Functions.....	11-1
11.2 Edge filtering settings:	11-7
11.2.1 What is Edge Filtering	11-7
11.2.2 Edge Filtering Details	11-8
11.3 Lighting:	11-12
11.3.1 Lighting Method:	11-12
11.4 Four point calibration (Coordinate conversion)	11-14
11.4.1 Description of functions.....	11-14
11.4.2 Use Limitations	11-14
11.4.3 Flow Configuration	11-15
11.5 Trigger Select	11-19
11.5.1 What is Trigger Select.....	11-19
11.5.2 Trigger Select Application Example.....	11-20
11.5.3 Trigger Select Setup	11-22

Chapter 1

Components and Specifications

1.1 Packaging and Optional Parts

A complete DMV system requires the following basic components:

- 1) Controller unit and keypad
- 2) Camera and 4.5 m cable (first set is included with the controller, and there is an optional second set)
- 3) Lens (optional)
- 4) Light source and dimmer (optional)

1.1.1 Controller Packaging

The following is included:

- Controller: DMV1000-80GX
- Operator: DMV1000-KEY
- 0.8 Megapixel (1024*768) grayscale camera: DMV-CD80GS
- 4.5 m 1394a-to-1394b cable: DMV-CA45

1.1.2 Camera (optional second camera)

Spec: 1/3" CCD with C mount

- 0.8 Megapixel (1024*768) grayscale camera: DMV-CD80GS
- 0.3 Megapixel (640*480) grayscale camera: DMV-CD30GS
- 4.5 m 1394a-to-1394b cable: DMV-CA45
- 1 m 1394a trigger cable: DMV-CA10T

1.1.3 Lens (optional)

Megapixel lens: 2/3" image size with C mount

- | | | |
|------------------------------------|------------------------------------|------------------------------------|
| ■ 8 mm focal length:
DMV-LN08M | ■ 16 mm focal length:
DMV-LN16M | ■ 35 mm focal length:
DMV-LN35M |
| ■ 12 mm focal length:
DMV-LN12M | ■ 25 mm focal length:
DMV-LN25M | ■ 50 mm focal length:
DMV-LN50M |

Telecentric Lens:

- 50 mm focal length: DMV-LN50T

1.1.4 LED Light Source (optional)

Ring:

- Red: DMV-DR6736R
 - White: DMV-DR6736W
 - Diffuser: DMV-DR6736D
- 30 degree lighting angle, 36 mm inner diameter, and 67 mm outer diameter for general text surfaces

Coaxial:

- White: DMV-CX40W
- 40 mm * 40 mm glass window for highly reflective (for example metal) surfaces.

Backlight:

- Red: DMV-BL60R
- 60 mm * 60 mm for backlight illumination during size measurement

Power Supply:

- 1-channel output:
DMV-PS12C1
- 2-channel output:
DMV-PS12C2
- Power cable extension:
DMV-CA30

The flashlight controller is built into the power supply and the DMV-CA30 (3 m) is included with the light source.

1.2 Controller unit and Keypad

1.2.1 Specifications

■ General specifications

Input power	24 VDC
Operation voltage	90%–110% of rated voltage
Power consumption	Less than 1A
Vibration resistance	10–55 Hz @ 10 m/s in 3-axis for 10 min
Shock resistance	Max 300 m/s in 3-axis and 6-orientation for 3-repetition
Operating temperature	0–50° C
Storage temperature	-20–65° C
Operating humidity	35%–65% RH (non-condensing)
Operating altitude	Lower than 2,000 m
Battery lifespan	More than 5 years

■ Functionality

Camera	Type	IEEE1394a digital grayscale camera
	Resolution	0.8 Megapixel camera: 1024 (H)*768 (V) @ 80 fps
		0.3 Megapixel camera: 640 (H)*480 (V) @ 30 fps
	Connected systems	Up to 2 units
	Shutter speed	0.05 ms–1s and custom (15 options)
Lens mount	C mount	
Project quantity		Internal memory: 32 (P000–P031); memory card: 968 (P032 – P999) Switch through either I/O or RS232/Ethernet
Inspection window	Quantity	128 per project
	Inspection item	Area, position, count, width, angle, match pattern, shape, intensity, blob, stain, position trace, width trace
	ROI type	Rectangle, circle, polygon, ellipse, ring, arc, rotated rectangle
	Mask quantity	4 per inspection window
Pre-processing	Total	13
	Mode	Gray cut, dilation, erosion, average, median, sharpen, Laplacian, SobelX, SobelY, Sobel, Prewitt, Roberts, subtract
Execute mode		Always execute, never execute, reference execute
Calculation processing	Total	32
	Arithmetic	Add, subtract, multiply, divide
	Function (14 total)	ABS, SQR, SQRT, MOD, POW, DIST, AVEG, MIN, MAX, LE, EQ, SIN, COS, TAN

Chapter 1: Components and Specifications

Judgment processing	Total	32
	Mode	AND, OR, XOR, NOT
Communication port		RS-232 (max 115,200 bps), USB2.0, Ethernet (10BASE-T), Delta PLC-Link
Display	Monitor screen	SVGA 800*600 output
	Display ratio	Adjustable 4–999%
	Operating language	Traditional Chinese, Simplified Chinese, English
Flashlight control		I/O port with 2 independent control sets
Memory card		SD card (max 16 GB)

■ Controller parts

Picture No.	Name	Description
1	Parallel I/O port	Input/output terminal
2	Input I/O terminal block	Input terminal
3	Output I/O terminal block	Output terminal
4	USB 2.0 port	Reserved
5	Ethernet port	10/100 BASE-T communication
6	Operator port	Connects to the keypad
7	RS232 serial port	Supports master/slave serial communication
8	VGA output port	Connects to external aftermarket VGA monitor
9	SD memory card	Saves project configuration and image backup
10	Camera 1 port	For cameras with 1024*768 and 640*480 resolutions
11	Camera 2 port	For cameras with 1024*768 and 640*480 resolutions

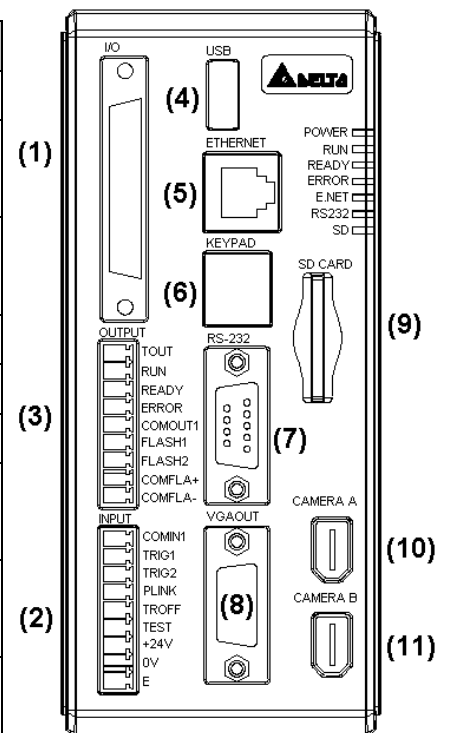

■ Keypad

Serial No.	Name	Description
1	Direction and enter keys	8-way movement and confirm
2	PROG/RUN	Switch between program and run modes
3	TRIGGER	Inspection trigger key
4	FUNC	Mode display while running
5	DISPLAY	Switch screen display between camera 1/2
6	CUSTOM	Switch between image pre-processing (RUN mode)
8	ESCAPE	Quit

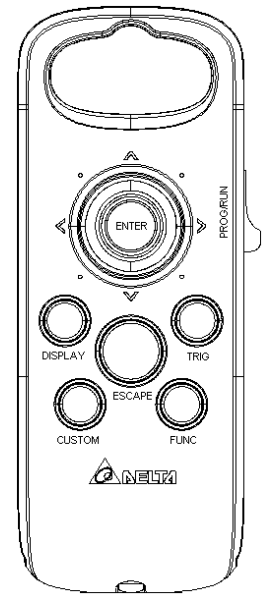

1.3 Camera and Lens

The DMV1000 controller supports the 1394a camera. The Delta DMV-80GS (0.8 Megapixel) and DMV-30GS (0.3 Megapixel) camera models are recommended. Before selecting the lens, confirm the field of view and working distance between the lens and test object. Refer to the table below for a suitable lens.

Field of view (mm) Horizontal (H)*Vertical (V)	Focal length 8 mm		Focal length 12 mm		Focal length 16 mm		Focal length 25 mm		Focal length 35 mm		Focal length 50 mm		Resolution um/pixel	
	Dis.	R	Dis.	R	Dis.	R	Dis.	R	Dis.	R	Dis.	R	640 * 480	1024 * 768
1000(H)*750(V)	1667	0											1562	977
800(H)*600(V)	1333	0	2013	0									1250	781
600(H)*450(V)	1000	0	1513	0	2015	0							938	586
500(H)*375(V)	833	0	1263	0	1683	0							781	488
400(H)*300(V)	667	0	1013	0	1348	0	2181	0					625	391
350(H)*263(V)	583	0	888	0	1181	0	1906	0					547	342
300(H)*225(V)	500	0	763	0	1014	0	1631	0	2253	0			469	293
250(H)*188(V)	417	0	638	0	847	0	1356	0	1878	0			391	244
225(H)*169(V)	375	0	575	0	764	0	1218	0	1690	0			352	220
200(H)*150(V)	333	0	513	0	681	0	1081	0	1503	0	2241	0	313	195
175(H)*131(V)	292	0	450	0	597	0	943	0	1315	0	1963	0	273	171
150(H)*113(V)	244	0	389	0	514	0	806	0	1128	0	1686	0	234	146
140(H)*105(V)	228	0	362	0	480	0	751	0	1053	0	1575	0	219	137
130(H)*98(V)	210	0	334	0	444	0	696	0	978	0	1464	0	203	127
120(H)*90(V)	193	0	307	0	407	0	641	0	903	0	1353	0	188	117

Chapter 1: Components and Specifications

Field of view (mm) Horizontal (H)*Vertical (V)	Focal length 8 mm		Focal length 12 mm		Focal length 16 mm		Focal length 25 mm		Focal length 35 mm		Focal length 50 mm		Resolution um/pixel	
	Dis.	R	Dis.	R	Dis.	R	Dis.	R	Dis.	R	Dis.	R	640 * 480	1024 * 768
110(H)*83(V)	175	0	280	0	371	0	586	0	828	0	1242	0	172	107
100(H)*75(V)	158	0	253	0	336	0	532	0	753	0	1131	0	156	97
90(H)*68(V)	142	0	227	0	300	0	477	0	678	0	1020	0	141	88
80(H)*60(V)	124	0	200	0	265	0	423	0	603	0	909	0	125	78
75(H)*56(V)	115	0.5	183	0	247	0	397	0	565	0	853	0	117	73
70(H)*53(V)	107	0.5	176	0	230	0	370	0	528	0	798	0	109	68
65(H)*49(V)	98	0.5	160	0	212	0	344	0	490	0	742	0	102	63
60(H)*45(V)	90	0.5	147	0	193	1	316	0	453	0	687	0	94	59
55(H)*41(V)	81	0.5	133	0.5	175	1	290	0	417	0	631	0	86	54
50(H)*38(V)	72	1	120	0.5	158	1	262	0	378	0	576	0	78	48.8
45(H)*34(V)	63	1	106	0.5	142	1.5	235	0	341	0	520	0	70	43.9
40(H)*30(V)	55	1	93	1	123	1.5	208	0	304	0	465	0	63	39.1
35(H)*26(V)	47	1	79	1	108	1.5	183	1	268	0	409	0	55	34.2
32.5(H)*24.4(V)	42	1	72	1	99	2	168	2	247	0	382	0	51	31.7
30.0(H)*22.5(V)	37	1.5	66	1.5	89	2	153	2	229	0	354	0	46.9	29.3
27.5(H)*20.6(V)	33	1.5	58	1.5	80	2	139	2	211	0	325	0	43.0	26.9
25.0(H)*18.8(V)	28	1.5	53	2	72	2	126	2	189	5	298	0	39.1	24.4
22.5(H)*16.9(V)	23	2	45	2			111	5	170	5	272	0	35.2	22.0
20.0(H)*15.0(V)	19	2	40	2			94	5	153	5	243	0	31.3	19.5
18.0(H)*13.5(V)	16	2	33	2			87	5	137	5	221	0	28.1	17.6
17.0(H)*12.8(V)	14	2					81	5	130	5	210	5	26.6	16.6
16.0(H)*12.0(V)					40	5	76	6	122	5	199	5	25.0	15.6
15.0(H)*11.3(V)					36	5	70	6	116	5	189	5	23.4	14.6
14.0(H)*10.0(V)			23	5	32	5	64	7	106	10	177	5	21.9	13.7
13.0(H)*9.8(V)			21	5	29	6	59	7	99	10	166	5	20.3	12.7
12.0(H)*9.0(V)			18	5	25	6	54	8	92	10	153	10	18.8	11.7
11.0(H)*8.3(V)			15	5	23	7	49	9	85	15	145	10	17.2	10.7
10.0(H)*7.5(V)			13	5	19	8	44	10	77	15	133	10	15.6	9.77
9.0(H)*6.75(V)			11	6	16	9	39	11	68	15	122	15	14.1	8.79
8.0(H)*6.00(V)			8	7	13	10	34	13	63	20	111	20	12.5	7.81
7.5(H)*5.63 (V)			8	7	10	10	31	14	58	20	104	20	11.7	7.32
7.0(H)*5.25(V)					7	11	27	16	53	20	99	25	10.9	6.84
6.5(H)*4.88(V)							25	18	51	25	92	25	10.2	6.35
6.0(H)*4.50(V)							23	20	46	25	88	30	9.38	5.86
5.5(H)*4.13(V)							21	22	44	30	84	35	8.59	5.37

Field of view (mm) Horizontal (H)*Vertical (V)	Focal length 8 mm		Focal length 12 mm		Focal length 16 mm		Focal length 25 mm		Focal length 35 mm		Focal length 50 mm		Resolution um/pixel	
	Dis.	R	Dis.	R	Dis.	R	Dis.	R	Dis.	R	Dis.	R	640 * 480	1024 * 768
5.0(H)*3.75(V)							17	24	39	30	76	40	7.81	4.88
4.5(H)*3.38(V)							14	26	35	35	72	45	7.03	4.39
4.0(H)*3.00(V)							12	30	33	40	66	50	6.25	3.91
3.5(H)*2.63(V)							9	34	27	45	60	60	5.47	3.42

 Remark Dis. is the working distance and R is the size of the extension ring

When the depth of field increases, the focal range also increases. The following conditions affect the depth of field.

- The longer the extension ring, the shallower the depth of field. The depth of field increases with the shorter extension ring.
- A longer working distance results in a greater depth of field.
- A smaller aperture results in a greater depth of field.
- A shorter focal distance of the lens results in a greater depth of field.

Chapter 2

Input and Output Interface

The DMV input and output interfaces include:

1. I/O terminal
2. RS232
3. USB
4. Ethernet
5. SD card

The pin definition and wiring connection are detailed below.

2.1 I/O Terminal Block

The I/O terminals are 9-pin and 50-pin type. The most used signals are on the 9-pin removable terminal and the remaining signals are on the 50-pin.



Reference

Refer to Chapter 8 for the purpose and timing of each terminal.

2.1.1 9-pin input terminals

Picture No.	Name	Description
1	COMIN1	9-pin common input (NPN / PNP)
2	TRIG1	Camera 1 trigger
3	TRIG2	Camera 2 trigger
4	PLINK	PLC data communication enable flag
5	TROFF	Trigger disabled (inspection disabled)
6	TEST	Status test (all results are not shown)
7	+24V	Positive input power
8	0V	Negative input power
9	E	Grounding

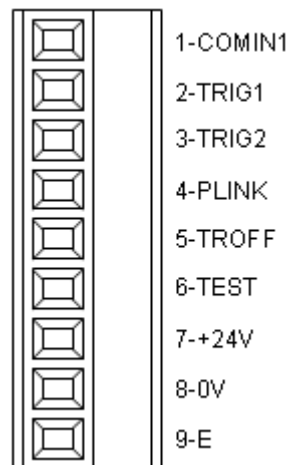

Input schematic (NPN input)

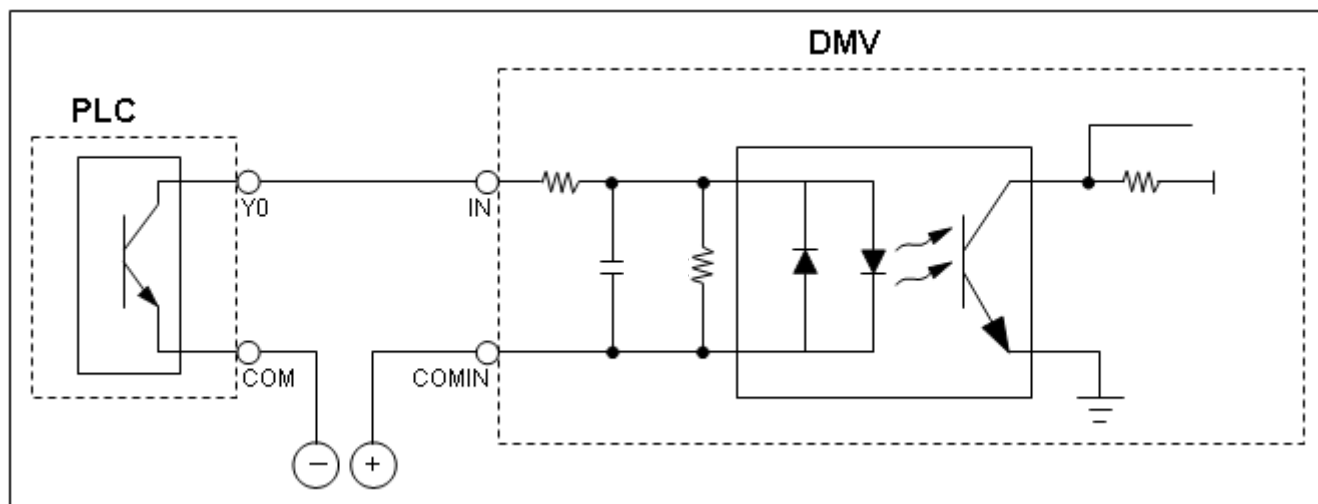

Input schematic (PNP input)

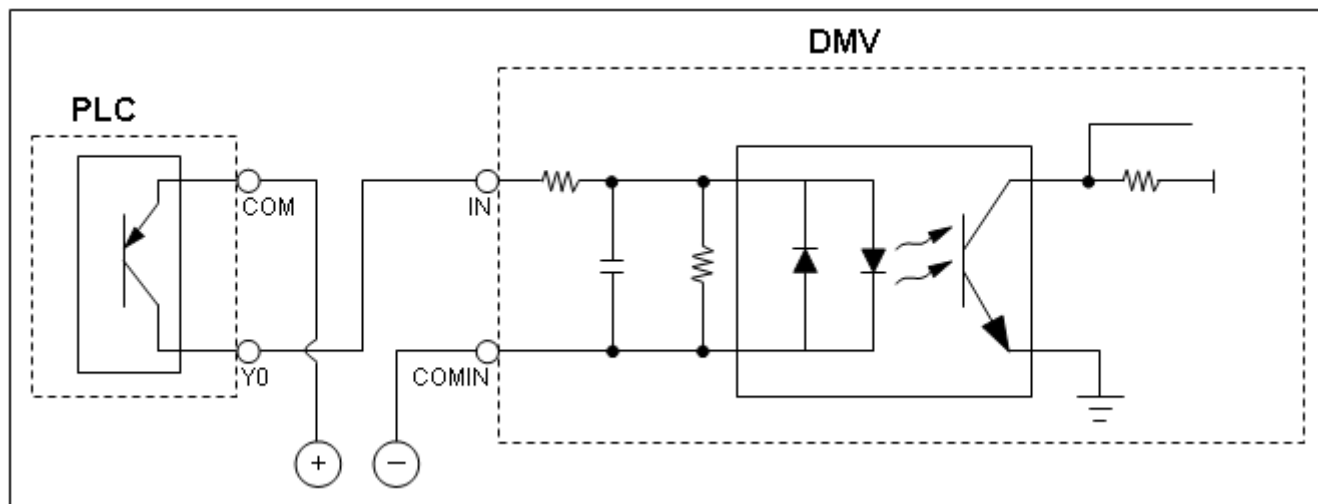

2.1.2 9-pin output terminals

Picture No.	Name	Description
1	TOUT	Overall result output (shows as OK/NG running on display)
2	RUN	Operation status indicator
3	READY	Controller in standby waiting for command and image inspection
4	ERROR	Error status indicator
5	COMOUT1	9-pin output common contact (please connect the NPN type to negative power source)
6	FLASH1	Camera 1 flash light output
7	FLASH2	Camera 2 flash light output
8	COMFLA+	Flash light common positive output
9	COMFLA -	Flash light common negative output

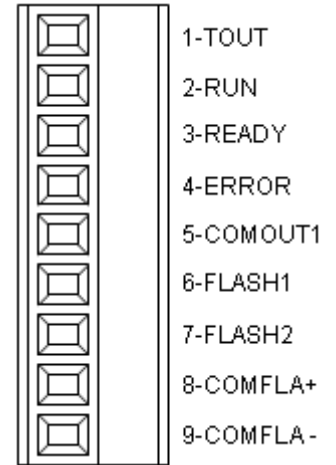

■ Output schematic (NPN output) (excluding FLASH1 and FLASH2)

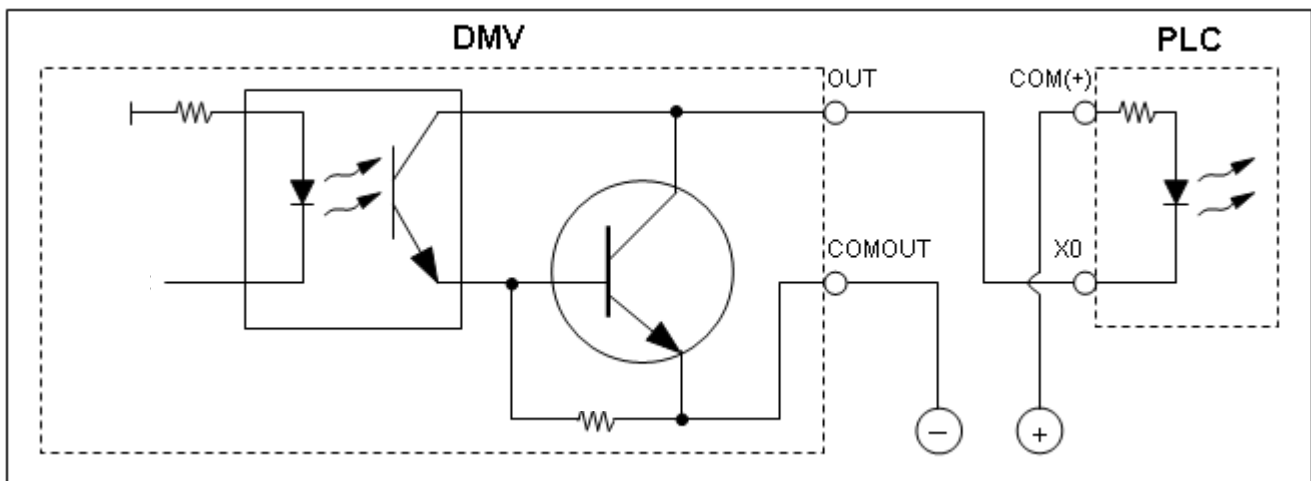

■ Light control FLASH1/2 output schematic (NPN output)

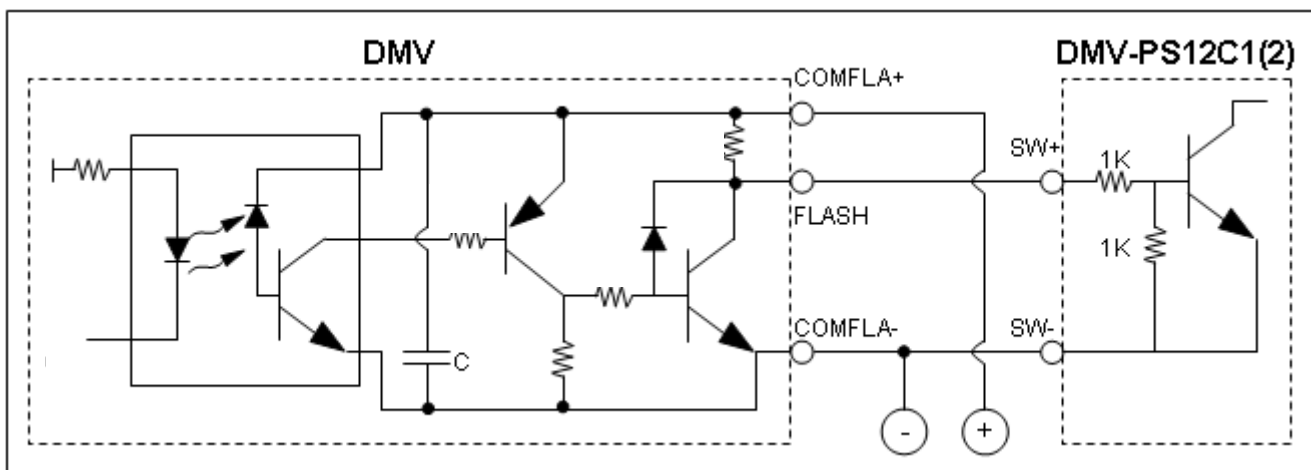

Reference DMV-PS12C1(2) is the light controller for the DMV series.

2.1.3 50-pin I/O mixed terminal

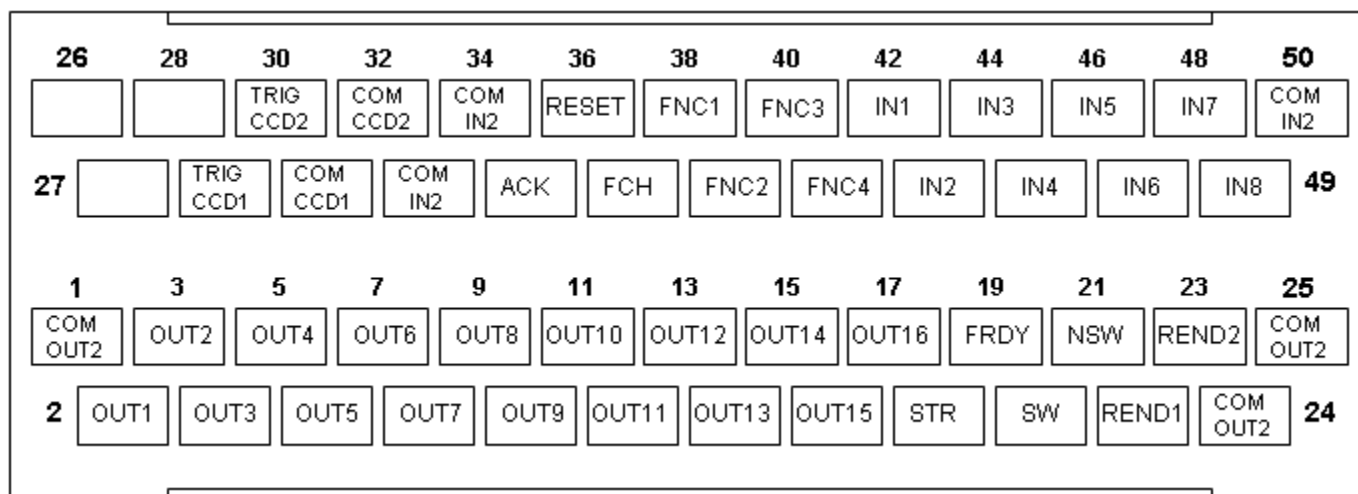

(Pinouts of the I/O male connector)

Input and output connection described in sections 2.1.1 and 2.1.2

Pin	Name	Description	Type
1	COMOUT2	Common 50-pin output	Output
2	OUT1	Parallel output 1	Output
3	OUT2	Parallel output 2	Output
4	OUT3	Parallel output 3	Output
5	OUT4	Parallel output 4	Output
6	OUT5	Parallel output 5	Output
7	OUT6	Parallel output 6	Output
8	OUT7	Parallel output 7	Output
9	OUT8	Parallel output 8	Output
10	OUT9	Parallel output 9	Output
11	OUT10	Parallel output 10	Output
12	OUT11	Parallel output 11	Output
13	OUT12	Parallel output 12	Output
14	OUT13	Parallel output 13	Output
15	OUT14	Parallel output 14	Output
16	OUT15	Parallel output 15	Output
17	OUT16	Parallel output 16	Output
18	STR	Parallel output handshaking flag	Output
19	FRDY	Allow function switching flag	Output
20	SW	Function switching success flag	Output
21	NSW	Function switching failed flag	Output
22	REND1	Camera 1 captured	Output
23	REND2	Camera 2 captured	Output
24	COMOUT2	Common 50-pin output	Output
25	COMOUT2	Common 50-pin output	Output

Pin	Name	Description	Type
26		Reserved	---
27		Reserved	---
28		Reserved	---
29	TRIGCCD1	Camera 1 internal trigger	Internal
30	TRIGCCD2	Camera 2 internal trigger	Internal
31	COMCCD1	Common TRIGCCD1	Internal
32	COMCCD2	Common TRIGCCD2	Internal
33	COMIN2	Common 50-pin input	Input
34	COMIN2	Common 50-pin input	Input
35	ACK	Parallel output handshaking flag	Input
36	RESET	System reset	Input
37	FCH	Function select trigger	Input
38	FNC1	Function select 1	Input
39	FNC2	Function select 2	Input
40	FNC3	Function select 3	Input
41	FNC4	Function select 4	Input
42	IN1	Number input 1	Input
43	IN2	Number input 2	Input
44	IN3	Number input 3	Input
45	IN4	Number input 4	Input
46	IN5	Number input 5	Input
47	IN6	Number input 6	Input
48	IN7	Number input 7	Input
49	IN8	Number input 8	Input
50	COMIN2	Common 50-pin input	Input

2.2 Grounding and Installation

2.2.1 Grounding

Precautions:

- Do not connect or disconnect the wires while the system is powered on.
- The grounding wire should be as short as possible using the regulation wire gauge. The grounding resistance must be under 100 Ω .
- Ground the grounding terminal using the correct method (example on left below). Do not directly connect to other power devices.

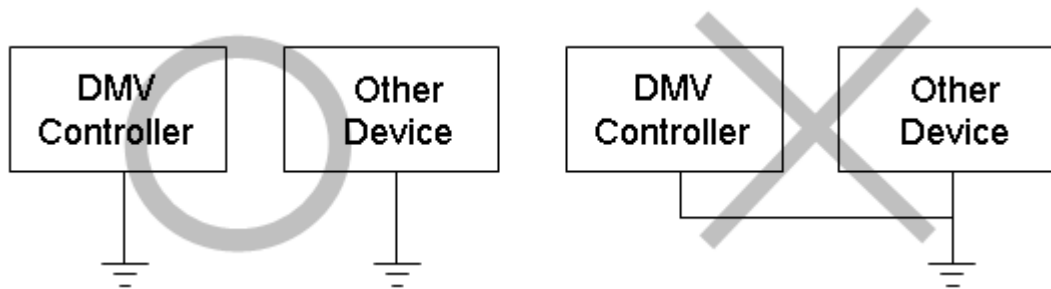

2.2.2 Installation

The DMV supports the DIN rail-type and screw-type installations.

- DIN rail-type:
 - To install: (Install in the 35 mm rail groove)
 1. Place the controller onto the DIN rails.
 2. Gently push down on the controller to fit it onto the DIN rails.
 - To uninstall:
 1. Insert a screwdriver into the DIN rail latch.
 2. Push down on the latch and lift the controller away.

Reserve at least 50 mm above and 30 mm to the left and right of the controller for proper ventilation. Excessive operating temperature due to insufficient cooling will damage the controller. Reserve at least 100 mm in front of the wiring panel for ease of access.

Chapter 3

Basic Operation

3.1 Keypad

You can use the DMV keypad unit to configure the interface. This chapter covers using the keypad to adjust the size of the viewing window.

3.1.1 What is the Region of Interest (ROI)?

Each inspection function must be configured with the imaging area to be inspected. This area is called the region of interest (ROI). You configure the ROI as described in the following steps.

- 1) [Program] > [Camera] > [Camera 1] and [Camera 2] > [Setup Area] to adjust the effective imaging window size.
- 2) [Program] > [Window] > [ROI] to adjust the ROI.
- 3) [Program] > [Window] > [ROI] to adjust the Mask [1–4].
- 4) [Program] > [Window] > [Shape] > [Parameter] > [Add Pattern] to set the pattern size.

You can use the following window shapes for different imaging requirements:

- 1) Rectangle
- 2) Circle
- 3) Polygon
- 4) Ellipse
- 5) Ring
- 6) Arc
- 7) Rotated rectangle

3.2 Draw the ROI (Region of Interest)

3.2.1 Draw a Rectangle

Follow these steps to draw a rectangle.

- 1) Initial rectangle; press **Enter** to show the top/bottom positions.
Use **Up** / **Down** / **Left** / **Right** on the keypad to move the entire object.

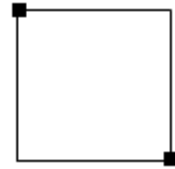

- 2) Press **Enter** to switch to the top left corner.
Use **Up** / **Down** / **Left** / **Right** on the keypad to move the top left corner.

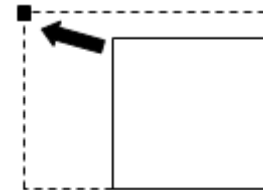

- 3) Press **Enter** to switch to the bottom right corner.
Use **Up** / **Down** / **Left** / **Right** on the keypad to move the bottom right corner.

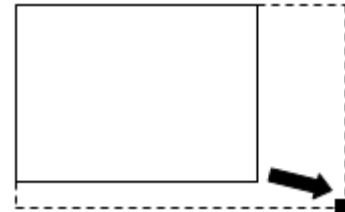

- 4) Press **Enter** to set the position of the rectangle.



- 5) Use the keypad to select the  icon on the right side of the screen, and then press **Enter** to finish drawing the rectangle and go back.

3.2.2 Draw a Circle

Follow these steps to draw a circle.

- 1) Initial circle; press **Enter** to show the center and right positions.
Use **Up** / **Down** / **Left** / **Right** on the keypad to move the entire object.

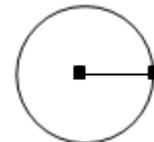

- 2) Press **Enter** to switch to the right position on the circumference.
Use **Up** / **Down** on the keypad to adjust the radius of the circle.

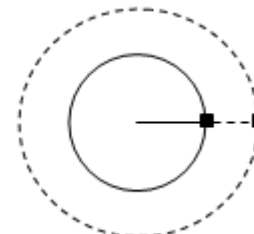

- 3) Press **Enter** to set the radius of the circle.



- 4) Use the keypad to select the  icon on the right side of the screen, and then press **Enter** to finish drawing the circle and go back.

3.2.3 Draw a Polygon

Follow these steps to draw a polygon (up to 12 sides).

- 1) Press **Enter** to show three vertices.
Use **Up** / **Down** / **Left** / **Right** on the keypad to move the entire object.

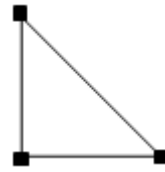

- 2) Press **Enter** to switch to the top (first) vertex.
Use **Up** / **Down** / **Left** / **Right** on the keypad to move the top vertex.



- 3) Press **Enter** to switch to the second vertex (moving clockwise).
Use **Up** / **Down** / **Left** / **Right** on the keypad to move the second vertex.

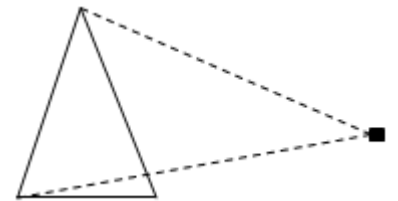

- 4) Repeat for the remaining third vertex.
In this state (no vertex labels), the [region] at the right becomes available.

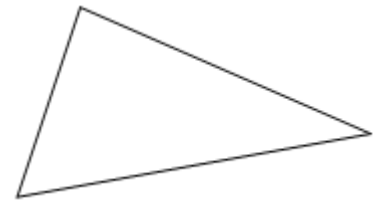

- 5) Use the keypad to select  to add the fourth vertex counter-clockwise to the first vertex. Press **Enter** to show the four vertices.

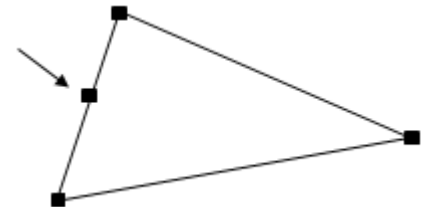

- 6) Follow steps 1–5 above to configure the polygon.

- 7) Use the keypad to select  again to delete the last vertex.

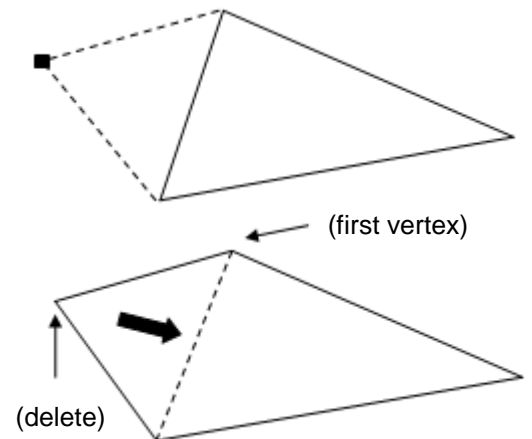

- 8) Use the keypad to select the  icon on the right side of the screen, and then press **Enter** to finish drawing the polygon and go back.

3.2.4 Draw an Ellipse

Follow these steps to draw an ellipse.

- 1) Initial ellipse; press **Enter** to show the center and four positions.
Use **Up** / **Down** / **Left** / **Right** on the keypad to move the entire object.

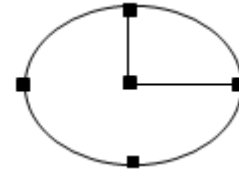

- 2) Press **Enter** to switch to the left/right positions.
Use **Up** / **Down** on the keypad to adjust the width of the ellipse.

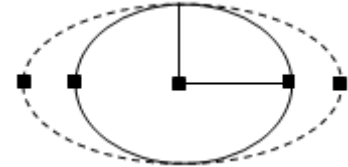

- 3) Press **Enter** to switch to the top/bottom positions.
Use **Up** / **Down** on the keypad to adjust the height of the ellipse.

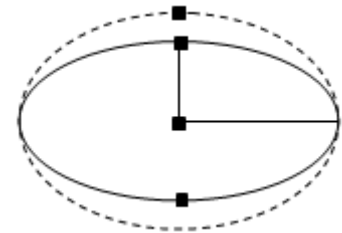

- 4) Press **Enter** to select all positions.
Use **Up** / **Down** on the keypad to adjust the orientation angle of the ellipse.

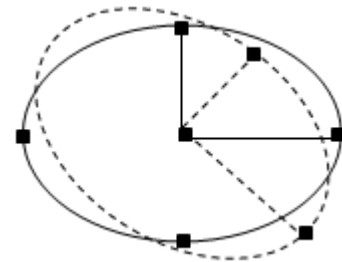

- 5) Press **Enter** to set the position of the ellipse.

- 6) Use the keypad to select the  icon on the right side of the screen, and then press **Enter** to finish drawing the ellipse and go back.

3.2.5 Draw a ring ROI

Follow these steps to draw a ring.

- 1) Initial ring; press **Enter** to show the center and inner/outer positions.
Use **Up** / **Down** / **Left** / **Right** on the keypad to move the entire object.

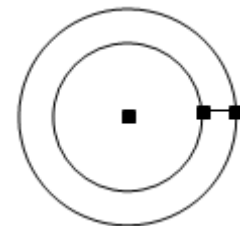

- 2) Press **Enter** to switch to the inner position.
Use **Up** / **Down** on the keypad to adjust the inner radius.

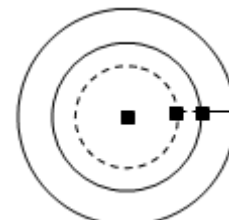

- 3) Press **Enter** to switch to the outer position.
Use **Up** / **Down** on the keypad to adjust the outer radius.

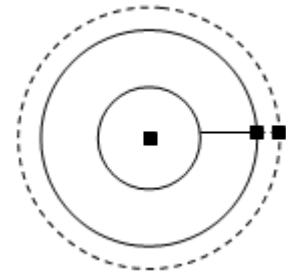

- 4) Press **Enter** to set the position of the ring.



- 5) Use the keypad to select the  icon on the right side of the screen, and then press **Enter** to finish drawing the ring and go back.

3.2.6 Draw an Arc

Follow these steps to draw an arc.

- 1) Initial arc; press **Enter** to show the center and inner/outer positions.
Use **Up** / **Down** / **Left** / **Right** on the keypad to move the entire object.



- 2) Press **Enter** to switch to the inner position.
Use **Up** / **Down** on the keypad to adjust the radius of the inner ring.



- 3) Press **Enter** to switch to the outer position.
Use **Up** / **Down** on the keypad to adjust the outer radius.

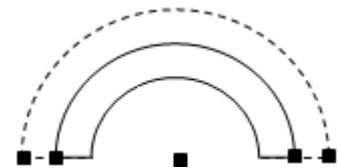

- 4) Press **Enter** to switch to the inner/outer positions on the right (arc length).
Use **Up** / **Down** on the keypad to adjust the right arc length.



- 5) Press **Enter** to switch to the inner/outer positions on the left.
Use **Up** / **Down** on the keypad to adjust the left arc length.



- 6) Press **Enter** to set the position of the arc.



- 7) Use the keypad to select the  icon on the right side of the screen, and then press **Enter** to finish drawing the arc and go back.

3.2.7 Draw a Rotated rectangle

Follow these steps to draw a rotated rectangle.

- 1) Initial rectangle; press **Enter** to show the center and four positions.
Use **Up** / **Down** / **Left** / **Right** on the keypad to move the entire object.

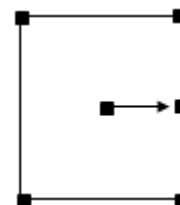

- 2) Press **Enter** to switch to the left/right positions.
Use **Up** / **Down** on the keypad to adjust width of the rectangle.

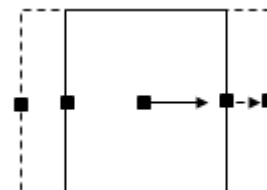

- 3) Press **Enter** to switch to the top/bottom positions.
Use **Up** / **Down** on the keypad to adjust height of the rectangle.



- 4) Press **Enter** to switch to the center and four positions.
Use **Up** / **Down** on the keypad to adjust the orientation angle of the rectangle.

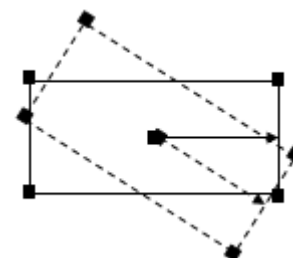

- 5) Press **Enter** to set the position of the rectangle.

- 6) Use the keypad to select the  icon on the right side of the screen, and then press **Enter** to finish drawing the rectangle and go back.

3.3 Region of Interest (ROI) Zoom

3.3.1 What is zoom?

When drawing the ROI as described in Section 3.2, you can zoom in/out and shift the image for more precise drawing.

As shown below, to fit the letter "E" in DELTA into the ROI you can zoom in on the image for more precise adjustments.

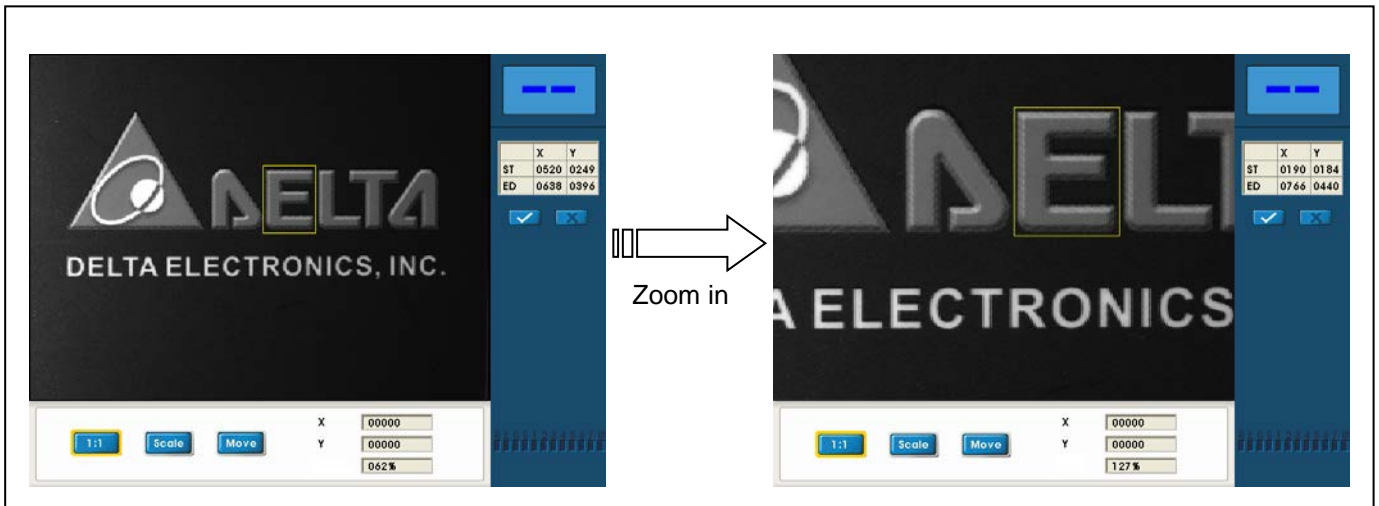

3.3.2 How to zoom

The Zoom function is available in the following five ROI states.

- 1) [Program] > [Camera 1–2] > [Setup Area] to adjust the window size.
- 2) [Program] > [Window] > [ROI] to set up.
- 3) [Program] > [Window] > [Mask Area 1–4] for set up.
- 4) [Program] > [Window] to setup the pattern for [Shape].
- 5) [System] > [Display] > [Screen] to move the group.



- **Open the ROI adjustment screen, [Program] > [Window] > [ROI] to set up.**

The initial screen is a 1:1 image.

■ Press [DISPLAY]

Adjust the zoom controls at the bottom of the screen, select using the **[Left]** / **[Right]** keys.

[1:1]: Return to original image.

[Scale]: Press **[ENTER]** and use the **[Up]** / **[Down]** keys to zoom (range is 1%–999%).

[Move]: Press **[ENTER]** and use **[Up]** / **[Down]** / **[Left]** / **[Right]** to move the image.

[X] [Y] [SIZE]: Shows the current position and zoom level.



i Remark

At 1:1, the zoom level is 62% due to the difference between 640*480 image resolution and 1024*768 camera resolution.

■ Edit the ROI

Adjust the image to size and then press **[Escape]** to close the configuration screen.

While zoomed in, refer to Section 3.2 "Draw Region of Interest (ROI)" to create the required ROI.



Chapter 4

Set Up the Inspection Process

The initial Controller Setup screen displays [Project list], [Program], and [System]. [Project list] and [Program] process flow are described in this chapter.

- [Project list] Settings
The controller internal memory can store up to 32 projects. You can create, edit, rename, copy, and delete projects. You can increase the total number of projects to 999 if you use a memory card.
- [Program] Settings
You can modify program parameters for the currently selected project. The six settings are [Camera], [Image], [Window], [Calculator], [Judgment], and [Output]. You configure all items to complete setting up an inspection program.
- [System] Settings
These are the parameters applied to all inspection projects. The settings are not affected by the individual project you select.

 **Reference** Refer to Chapter 5 for [System].

- Block diagram:

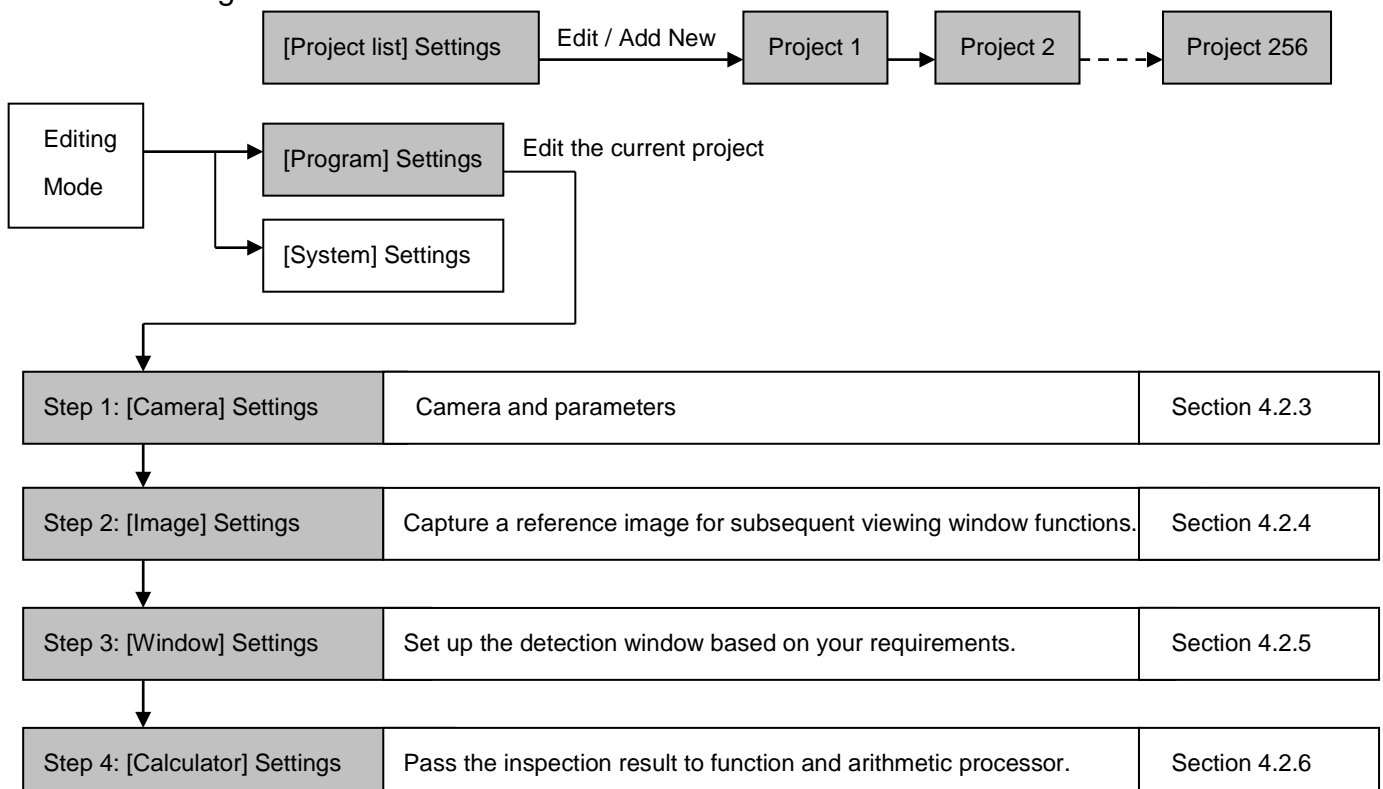

↓		
↓		
Step 5: [Judgment] Settings	Perform Boolean logic on the inspection and calculator results.	Section 4.2.7
↓		
Step 6: [Output] Settings	Set up the device and data output.	Section 4.2.8

4.1 [Project list]

4.1.1 What is a project?

Each complete inspection cycle is a project. You set up a new project specifically for different test subjects, and project settings are not shared.

For example, you might set up two projects: counter and width measurement for test subject A, positioning and defect detection for test subject B. The inspection functions for A and B are different, and they are individual projects.

4.1.2 Project setup (add project)

Select [Project list] in the edit screen:

The controller internal memory supports up to 32 projects can be expanded to 999 with a memory card.

Remark Use the **left** and **right** arrow keys can to quickly flip back and forth between multiple display pages.

■ Select [New] to open a new dialog box where you enter the project ID and name and then select [OK].

Set the ID to P000–P031 for internal memory.

Set the ID to P032–P999 for memory card.

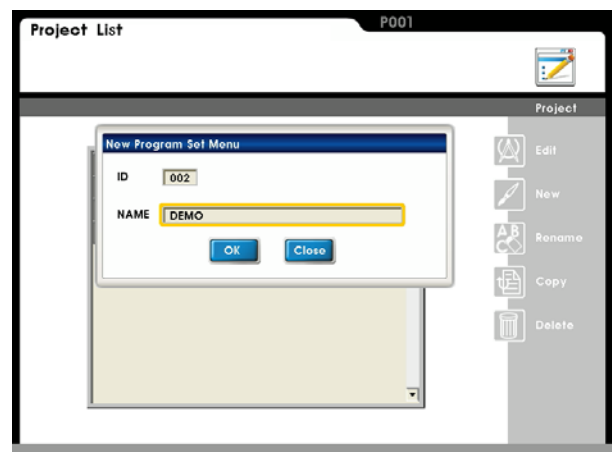
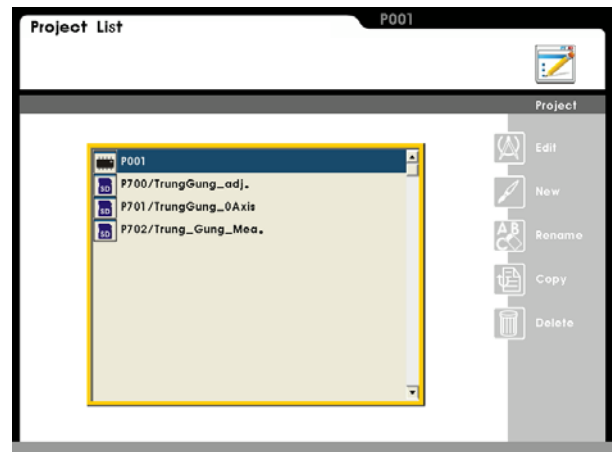

If an ID is already in use, the red * displays to the right of the ID. Enter a different ID for the project. A warning message displays if you try to add a duplicate ID.

- Select [Rename] to rename the project.

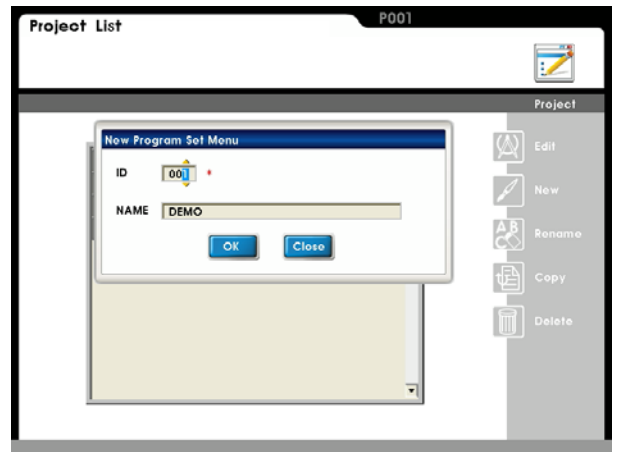

- Select [Copy] to copy an existing project. As shown to the right: Entering '001' for [From ID] and '010' for [To ID], and then selecting [OK] copies the project contents from project P001 to project P010. The project name is also copied.

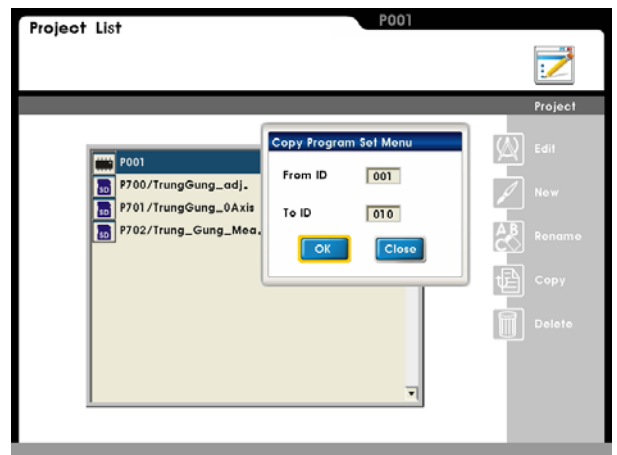

- Select [Delete] to delete the project's name and all project settings.

- Select [Edit] to select the project you want to edit. Select the ID and press [Enter] to switch to the editing project window.

The current project ID and name are listed to the right. For example, the picture shows switching from P000 ABC to P004 DELTA.

In addition to switching projects from the keypad, you can also use the RS232 (serial) and I/O (parallel) communication to switch projects.

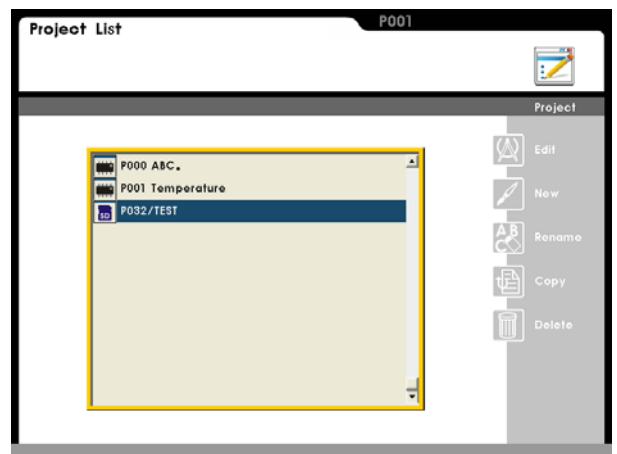

Reference

Refer to Sections 8.1.7 and 9.4 for RS232 and I/O project switching.

4.2 [Program] Settings

4.2.1 What is a [Program]?

[Program] includes the complete settings for an inspection cycle including [Camera], [Image], [Window], [Calculator], [Judgment], and [Output]. These settings constitute a program.

4.2.2 [Program] Setup

- Select [Program] from the edit screen

There are six options on top of the screen: [Camera], [Image], [Window], [Calculator], [Judgment], and [Output]. Set up each option from left to right to fully program a project.



4.2.3 [Camera] setup

The DMV supports two cameras working simultaneously, so there are separate settings for [Camera 1], [Camera 2], [Trigger], and [Flash].

- [Camera 1] and [Camera 2] are set up the same way. Select [Camera 1] or [Camera 2].

- [Gain Set]:

Range 0–100 (default is 50). Higher gain results in a brighter image but may generate more noise.

- [Brightness Set]:

Range 0–100 (default 50). Higher brightness results in a brighter image but is less effective than the Gain setting in terms of actual luminosity.

- [Trigger Mode]:

If the cameras are triggered externally, Camera 1 takes priority when you use the same trigger source for both Camera 1 and Camera 2.

- [Scan Mode]:

Progressive: Scan all lines in the image. All 0.80 M pixels are transferred for a 1024*768 image.

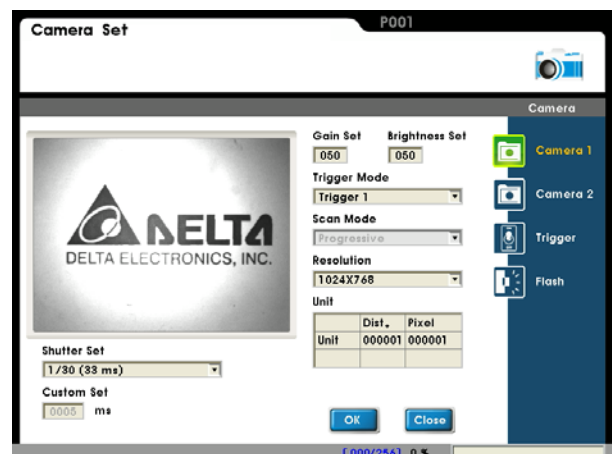

Interlaced: Scan every other line in the image. Only 1024*384 pixels are transferred for a 1024*768 image to reduce data and transfer time. Although image quality is reduced, the overall inspection speed increases if the quality is within tolerance.

- [Resolution]:

Select the resolution to display on the screen (1024*768, 800*600, or 640*480).

- [Unit]:

Select the ratio of image pixels to actual distance.

- [Shutter Set]:

Select the shutter settings (default 33 ms). A slower shutter speed (a longer exposure time) is better for dimly lit environments.

However, using a longer shutter speed when there is movement may result in blurry images.

- [Custom Set]:

Select a custom shutter speed when the default options do not meet the requirements. Set the custom shutter speed in milliseconds (ms).

The top left image refreshes when you change the [Gain], [Brightness], and [Shutter] settings. You can check to ensure that the final settings satisfy the requirements.

 **Reference** Refer to Section 3.2.3 for instructions on drawing the rectangle in the inspection area.

Select [Trigger].

- [Trigger Select]:

Select the camera trigger to be an External or Internal Trigger.

- [External trigger]:

Select the check boxes to enable the external trigger(s).

Keypad: Press the [Trigger] button to capture an image.

IO: Trigger the camera through the external I/O terminal.

RS232: Trigger the camera through the serial port.

USB: Trigger the camera through the USB port.

Ethernet: Trigger the camera through the Ethernet port.

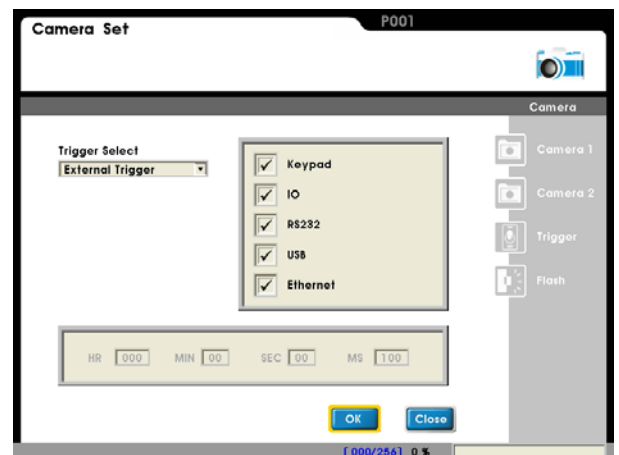

Chapter 4: Set Up the Inspection Process

- [Internal trigger]:

Auto-trigger periodically for a timed inspection application.

Note that the trigger interval must be longer than the image inspection time. If the trigger interval is shorter than the inspection time, the current inspection cycle must complete before the next cycle can start. As a result, the trigger interval is delayed waiting for the inspection to complete.

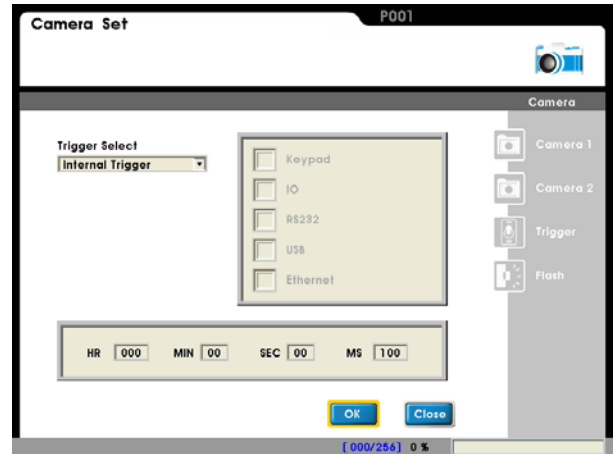

Select [Flash].

- [Flash]:

Flash controls the lighting output in sync with the camera shutter. As an LED's lifespan is greatly affected by the operating temperature, most LED dimmers feature the flash trigger input.

Camera 1 and Camera 2 are configured independently.

- [Flash 1] [Flash 2]

Select ON to enable flash output separately for each camera.

- [Flash Action Select]

Before: Trigger the flash before the shutter.

After: Trigger the flash after the shutter.

- [Flash Action Time]

Relative time interval between the flash and shutter trigger. The action depends on the [Flash Action Select] setting.

Before: Delay triggering the shutter after the flash output by this time interval.

After: Delay triggering the flash rafter the shutter has activated by this time interval.

- [Output time]

The length of the flash output. Set the flash output time for both Before and After actions.

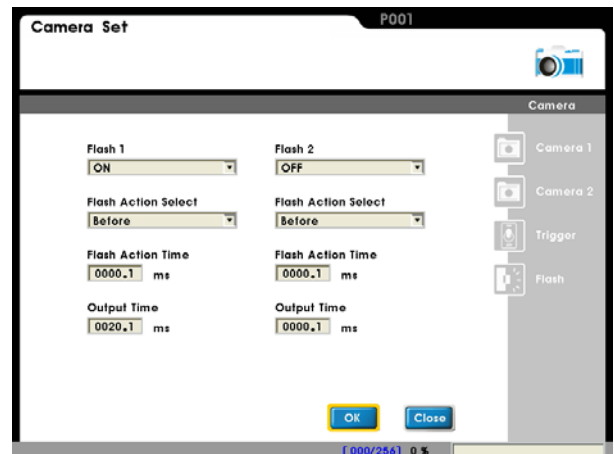

Flash output is generally triggered before the shutter for stable and sufficient illumination. The flash controller (DMV-PS12C2) has a 2 ms latency to the LED output after receiving the trigger signal. The following settings are therefore recommended when you set the shutter time to 33 ms:

- 1) Set [Flash Action Select] to Before.
- 2) Set [Flash Action Time] to greater than 2 ms so that the shutter is activated only after the LED output is fully lit.
- 3) Set [Output Time] to a minimum of 35 ms (2 ms + 33 ms) to match the shutter with the flash output.

**Reference**

Refer to Section 8.1.3 for the flash timing sequence.

4.2.4 [Image] Settings

Save an image as a reference for subsequent inspection processes.

- The image list contains the saved reference images and file names.

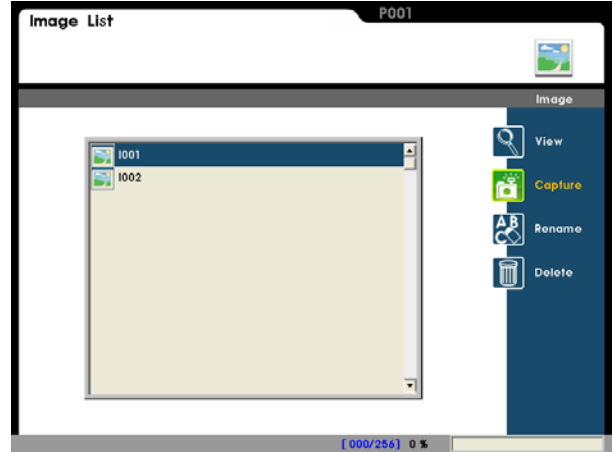

- Select an image and then select [View] to preview the saved image.

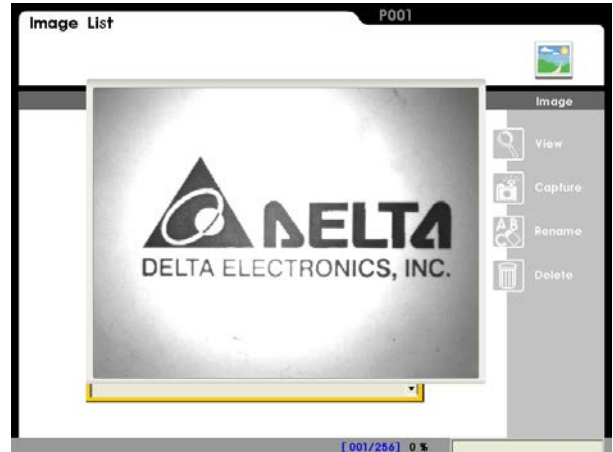

- Select [Capture] to add a new image. Choose the camera in [Camera Select] and then click the  button to capture the camera image. Select the [Live] check box to display a live image. The image refreshes continuously, so you can make real-time adjustments.



- Enter the image ID and Name. If the ID is already used, a red * appears to the right of the ID. Click



to save the image.

To use an existing ID, delete the existing image and then recapture the image. You cannot directly overwrite an image with an existing ID.

- Select [Rename] to rename the saved image.
- Select [Delete] to delete the saved image.



4.2.5 [Detection Window] settings

Each project supports 128 (W000–W127) detection windows. Each detection window performs one inspection function. As the windows are processed in ascending order, use a lower ID for the position-finding functions so that the position can be referenced later by the system. Reserve the first few IDs for detection window positioning functions. We recommend starting from ID W005.

- Detection Window setup
 - [Edit]: Edit the window function. The function selection dialog is automatically opened for a new inspection window.
 - [New]: Open the function selection dialog of the detection window to select a new item.
 - [Copy]: Use copy to copy the inspection settings from the current detection window to other detection windows, as explained below.
 - [Delete]: Delete the detection window.

A red exclamation mark indicates an incomplete detection window.

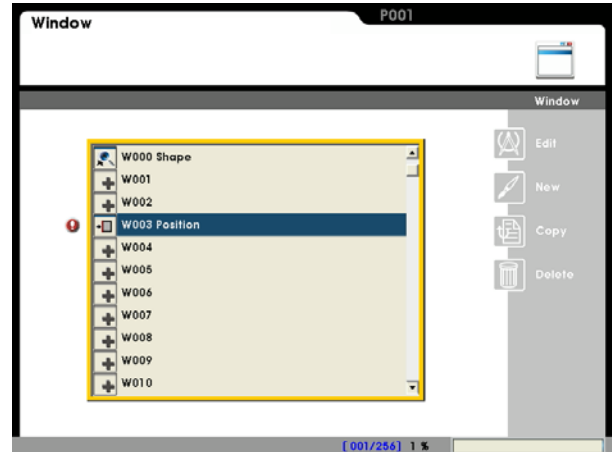

- [Copy] a detection window

Select a single detection window (source) and then select multiple windows (targets) for copying.

As shown: First select W000 Shape and then select W004, W005, and W006 to copy W000 to W004–W006.

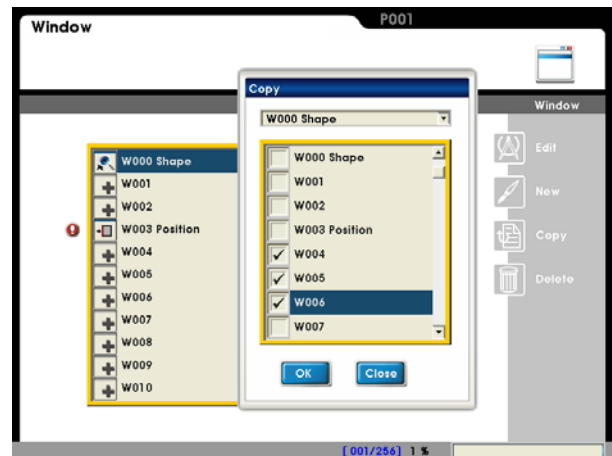

- Select [Edit] > [Setup]

Set up the functions from top to bottom: [Source], [Pre-processing], [ROI], [Parameters], [Limit], [Coordinate], and [Execute].

Reference Refer to Chapter 6 for detailed description on each function.



4.2.6 [Calculator] settings

Each project supports 32 (C00–C31) calculators to be applied to the inspection results. The calculator includes functions that can perform algebra and trigonometry calculations, and the result can also be used by the subsequent calculators, [Judgment] and [Output] programs. For example: you can use [Edge position] twice to determine the sides and angles of a triangle. Then the third side and angle can be calculated to simplify inspection functions and reduce overall inspection time.

- Calculator setup
 - [Edit]: Edit the selected calculator.
 - [Rename]: Set or modify the calculator name (up to 20 characters).
 - [Copy]: Copy the selected calculator to other calculators (as explained below)
 - [Delete]: Clear all calculator contents.

A red exclamation mark indicates that the calculator contains invalid settings.

■ [Copy] calculator

Select a single source and then select multiple destinations to copy.

As shown: Select [Copy], then select calculator C00, and then select C04, C05, and C06 to copy the C00 calculations to C04–C06.

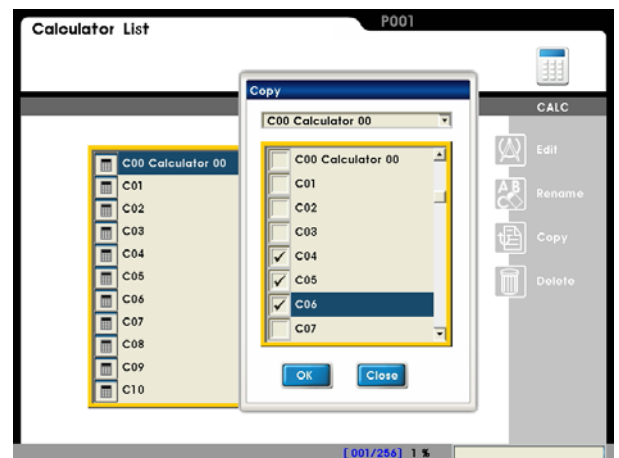
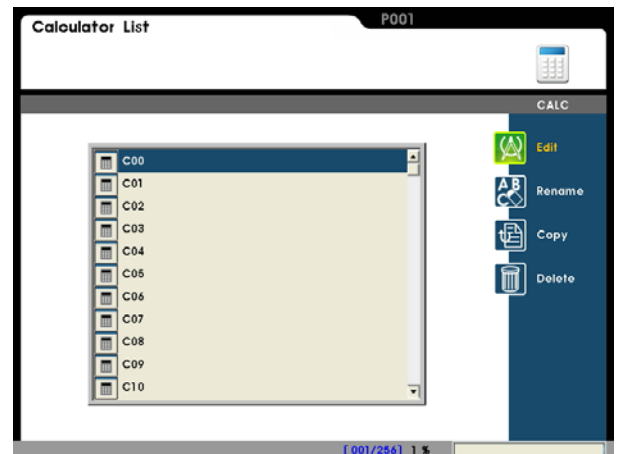

Chapter 4: Set Up the Inspection Process

■ [Edit] calculator

This opens the calculator editor. Use the buttons to enter the equation as shown in the picture.

The system can compare the calculator results to the [Upper] and [Lower] bounds. The system can also use the Boolean result of the comparison OK (1) and NG (0) in the subsequent [Judgment] and [Output] programs.

Calculator results can also be used by subsequent calculators. For example, if the C00 output is 500 and $C01 = C00 + 200$, then C01 output is 700.

Reference Refer to Chapter 7 for a detailed description on [Calculator].

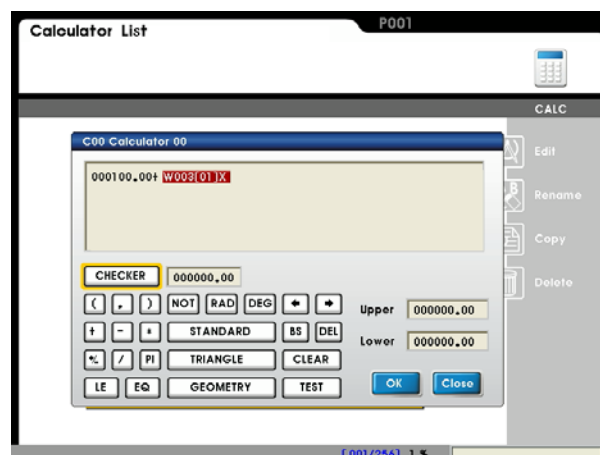

4.2.7 [Judgment] settings

Each project supports 32 (J00–J31) judgments for the inspection function and calculator results. The Boolean result OK (1) and NG (0) from a judgment can also be used by the subsequent [Output] process.

- Judgment editor:
 - [Edit]: Edit the selected judgment.
 - [Rename]: Set or modify the judgment name (up to 20 characters)
 - [Copy]: Copy the selected judgment to other judgments (as explained below)
 - [Delete]: Clear all judgment contents.

A red exclamation mark indicates that the judgment contains invalid settings.

- [Copy] Judgment:

Select a single source and then select multiple destinations to copy.

As shown: Select [Copy], then select judgment J01 and then select J04, J05, and J06 to copy the J00 judgments to J04–J06.

- [Edit] Judgment:

This opens the judgment editor. Use the buttons to enter the logic equation as shown in the picture.

The system can use judgment results in subsequent judgments. For example, if J00 output is OK (1) and $J01 = J00 \text{ OR } 0$, then J01 output is 1.

 **Reference** Refer to Chapter 7 for a detailed description on [Judgment].

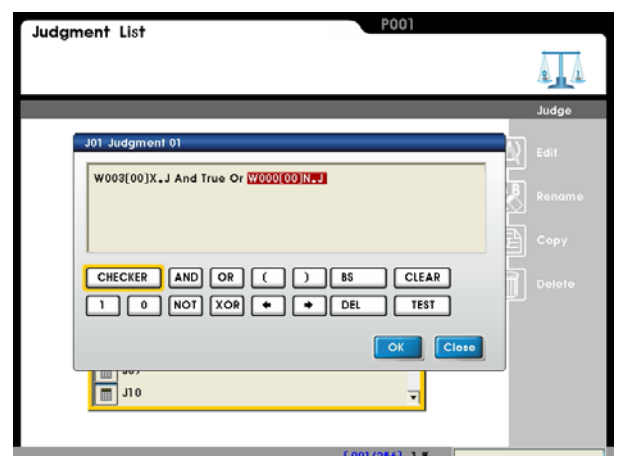
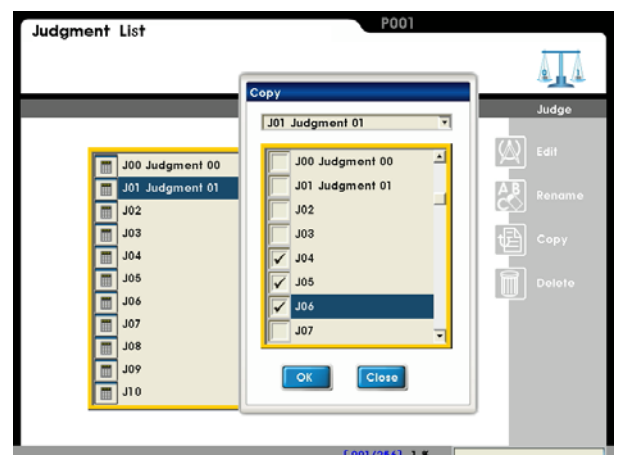
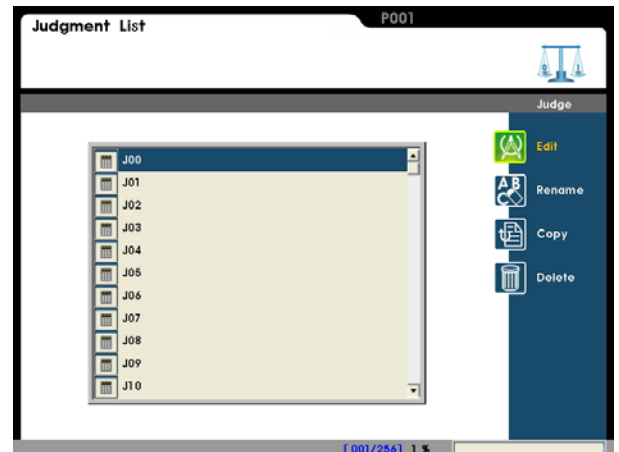

4.2.8 [Output]

After inspection and calculation are completed, you can select the [Window], [Calculator], and [Judgment] results for output. Output supports multiple interfaces and display methods, including [Memory], [Status], [Parallel], [RS232], [Ethernet], [SD Card], and [Image].

You can select interfaces independently or in multiples simultaneously based on requirements. For example, send only the inspection result to a PLC through RS232, and send all data to the PC through Ethernet for database management.

■ [Memory] Settings

There are 16 internal registers for output data.

- For example, if you set Field02 to C00(00)V, it stores the result of calculator C00 in this internal register.

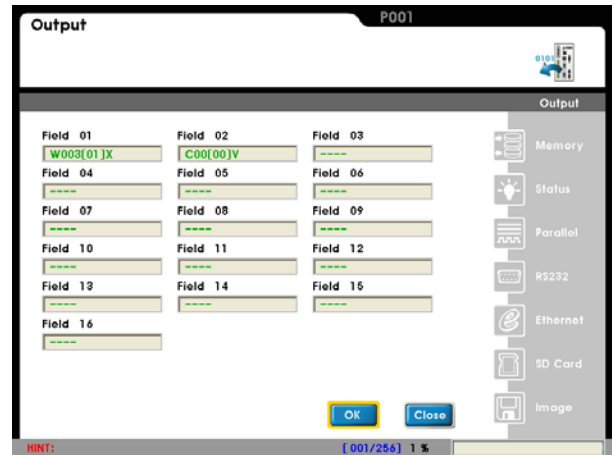

■ [Status] Settings

The following status indicators are accessible at the RUN screen.

- Summary output for the inspection - OK (green) and NG (red) status indicators in the top right corner.
- Logic state display - Gray (pending), green (OK), and red (NG) status indicators along the bottom.

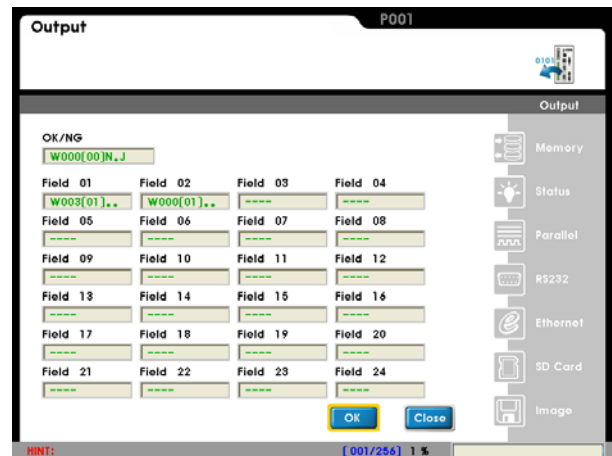

■ Output interfaces

- [Parallel]: Output to the 16 I/O terminals.
- [RS232]: Output to the RS232 port either directly or to PLC-link.
- [Ethernet]: Output data to the Ethernet port.
- [USB]: Output data to the USB port.
- [SD Card]: Save data to an SD memory card in the CSV format that you can open in Microsoft Excel on a PC.
- [Image]: Save image source and interface (Ethernet, USB, SD Card).

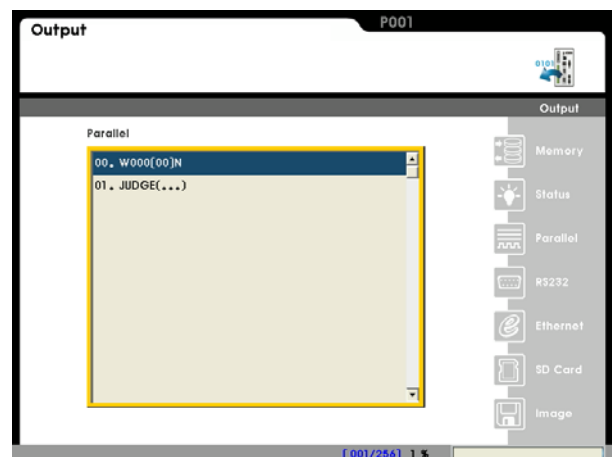

■ Set up output to an interface

Select the output interface. Use the [Add Parameter] and [Add Judgment] options to output to the following interfaces: [Parallel], [RS232], [Ethernet], [USB], and [SD Card].

The output sequence starts from the top of the list and goes down in order. Select an output and then use the [Up] and [Down] options to change the output ordering.

Use [Delete] to delete the selected output.

■ [Image] Settings

You can use the Image output to determine if the image is properly saved during the inspection. You can also reference the image later for statistics and defect analysis.

Reference Refer to Chapter 7 for a detailed description of [Output].

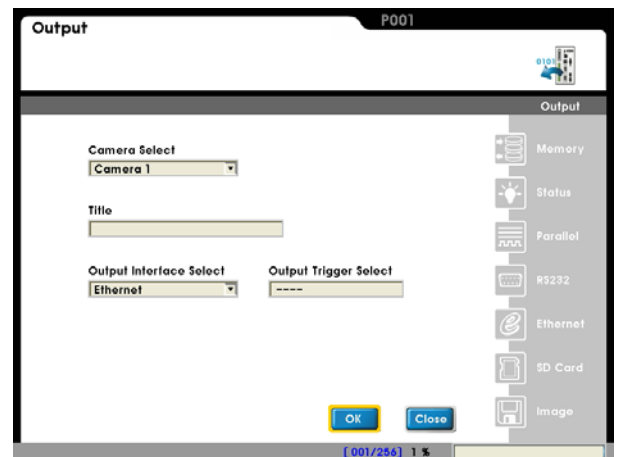
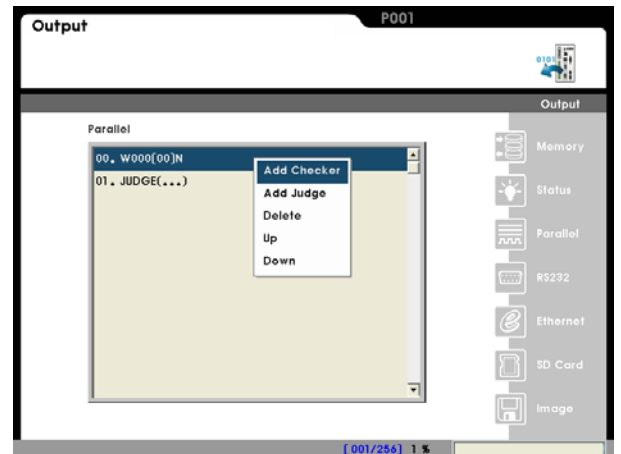

Chapter 5

System Setup

The initial Controller Setup screen displays [Project list], [Program], and [System]. The [System] settings are described in this chapter.

[Project list] Settings

The controller internal memory stores up to 32 projects. You can create, switch, edit, rename, copy, and delete the projects. You can increase the total number of projects to 999 if you use an SD card.

 **Reference** Refer to section 4.1 for [Project list].

[Program] Settings

You can modify project parameters for the currently selected project. The six settings are [Camera], [Image], [Window], [Calculator], [Judge], and [Output]. You configure all items to complete setting up an inspection project.

 **Reference** Refer to section 4.2 for [Program].

[System] Settings:

These are the parameters that are applied to all inspection projects. These settings are not affected by individual project you select.

Block diagram:

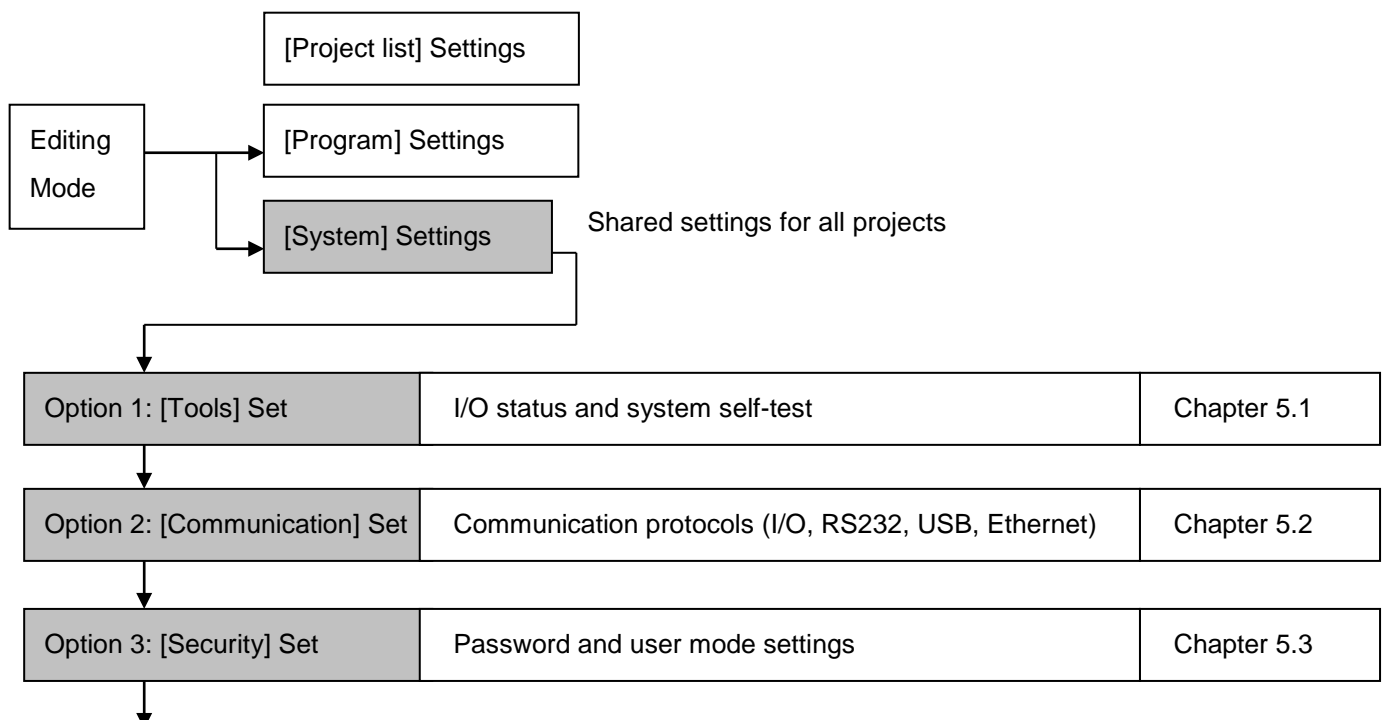

Option 4: [Display] Set	Display language, ROI sync, and imaging display method settings	Chapter 5.4
Option 5: [Global] Set	Startup state and system calendar	Chapter 5.5
Option 6: [Information]	System information and factory default	Chapter 5.6

5.1 [Tools] Set

Option 1: [I/O Status]

Manually set the output state and view the current input states for initial troubleshooting.

You can manually set the output state to ON or OFF. The output is ON when selected, which enables the hardware output.

The input state is read-only. External input signals are immediately updated on the screen.

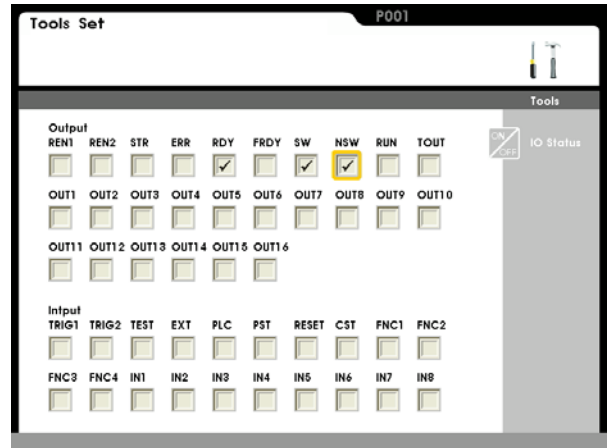

5.2 [Communication] Set

Option 1: [Memory]

Configure and review the 16 built-in internal memory fields.

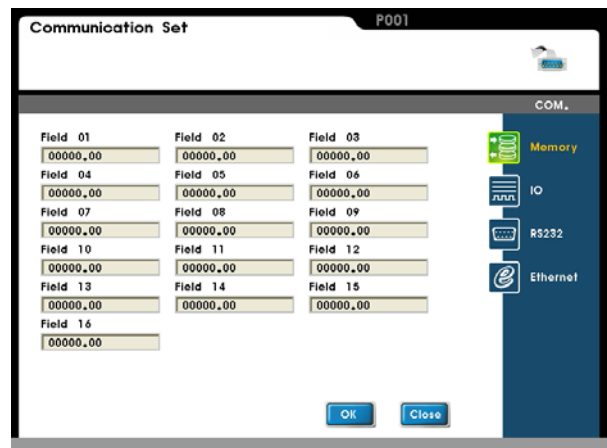

■ **Option 2-1: [External terminal] > [Handshake Select] = OFF**

When the external terminal (I/O output) signal handshake is OFF, the STR and result output signals are transmitted according to a timer.

STR start delay: STR start delay time after data output (T1).

STR Output Time: Allows time for DMV STR duration to ensure that PLC data output is complete (T2).

Data Output Time: Required output time for each data entry (T3).

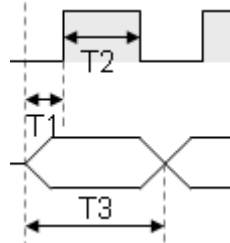

Reference Refer to section 8.1.4 for detailed timing sequence.

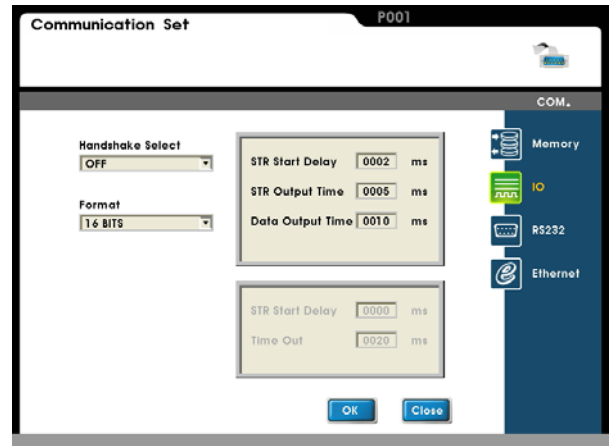

■ **Option 2-2: [External terminal] > [Handshake Select] = ON**

When the external terminal (I/O output) signal handshake is ON, the STR and ACK signal handshakes control the result output.

STR start delay: STR start delay time after data output (T1).

Time Out: PLC returns the ACK signal after STR output. Communication error occurs when this timeout is reached.

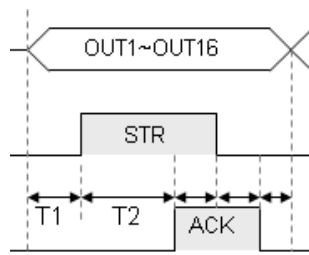

Reference Refer to section 8.1.4 for the detailed timing sequence.

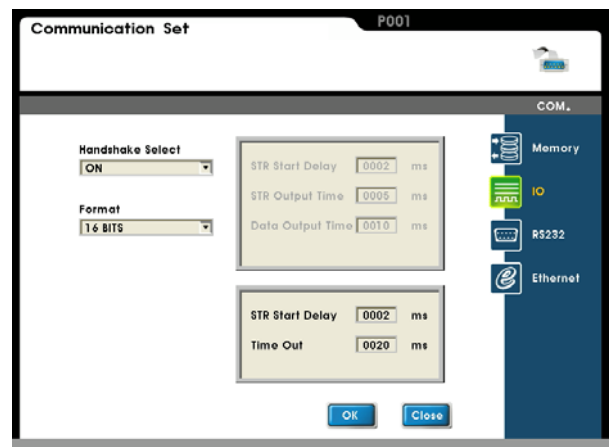

■ Option 3: [RS232]

Sets the RS232 communication format for PLC-link function to console.

Default: 9600, 7, E, 1 (Delta PLC default communication format)

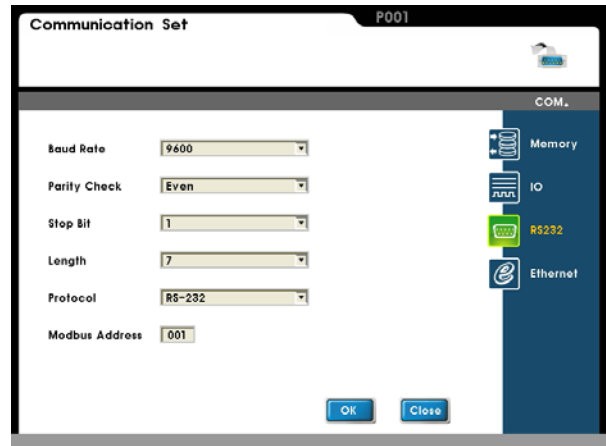

■ Option 4: [Ethernet]

Sets the Ethernet IP address.

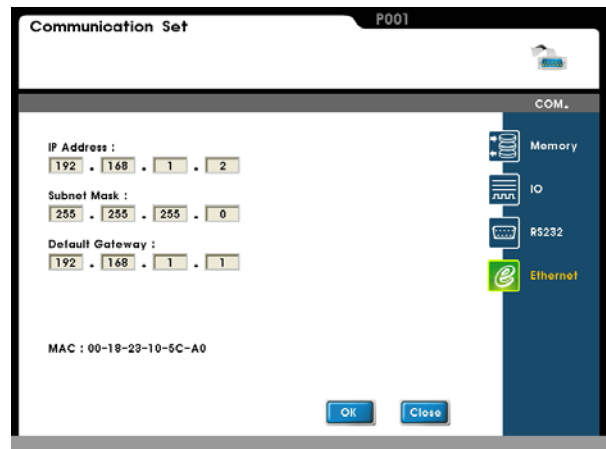

5.3 [Security] Set

■ Option 1: [Password]

Sets the user password. The system features a password protection user mode. When the password is enabled, you must enter the password in order to access the operation mode.

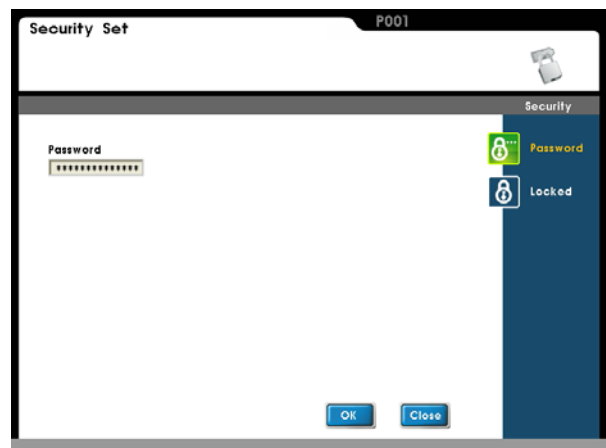

■ Option 2: [Locked]

Enables the user protection mode. The password is required to enable/disable the lock.

System Lock: The password is required to switch between RUN and PROG modes.

Write protect: The password is required to change this setting.

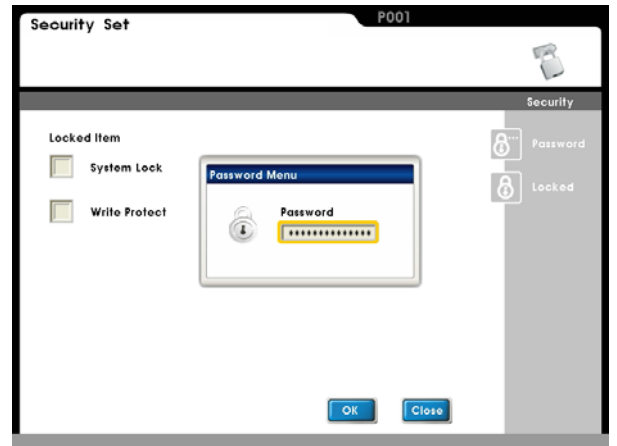

5.4 [Display] Set

■ Option 1: [Language]

Selects one of the three built-in languages: English, Traditional Chinese, and Simplified Chinese.

Select a different language mode to immediately change the displayed language.

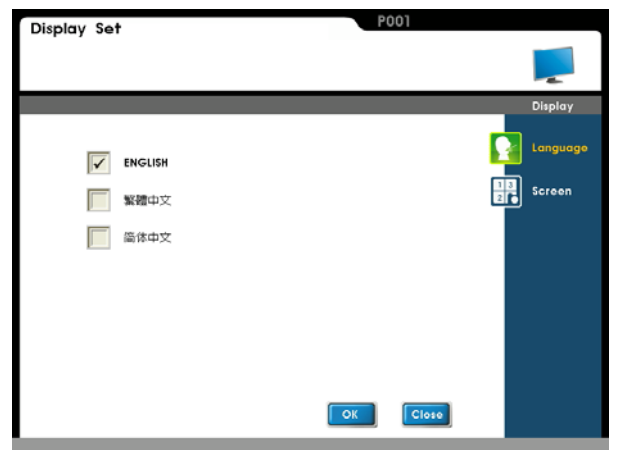

■ Option 3: [Screen]

Sets the Setting and RUN mode to control auto/trigger camera capture.

● Setting Mode

Keypad: Press [TRIG] on the keypad to capture an image.

Live: The system automatically and continuously updates the image.

● RUN mode

Trigger: Press [TRIG] on the keypad to capture and inspect an image.

Live: The system automatically and continuously updates the image before inputting [TRIG]. After entering [TRIG], captures a new image for inspection.

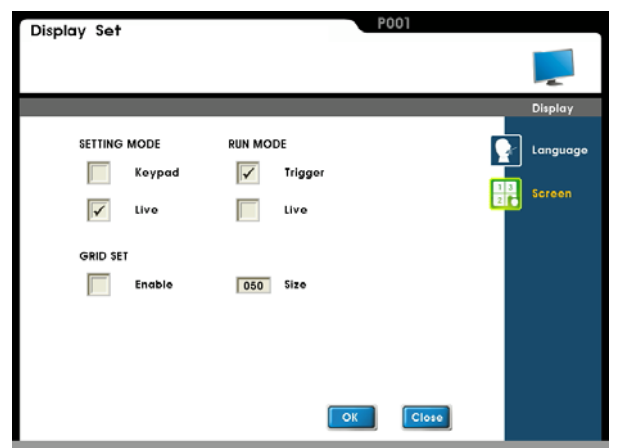

5.5 [Global] Set

■ Option 1: [Start Set]

Specifies the preferred startup mode for the system (Program mode or RUN mode).

- Setting Mode: Enter program mode at system startup.
- RUN Mode: Enter RUN mode at system startup.

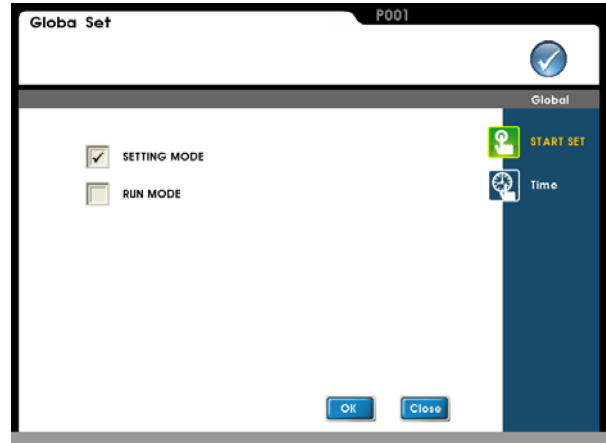

■ Option 2: [Time]

Sets the system calendar date and time.

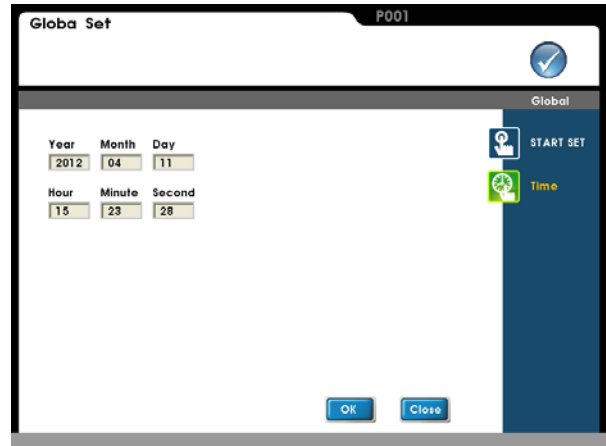

5.6 [Information]

■ Option 1: [Information]

Shows the current machine vision MCU, DSP, and FPGA modules versions.



■ Option 2: [Factory]

Restores the system to the factory default settings.

Projects stored in internal memory are deleted.

Projects on SD Card are not deleted.

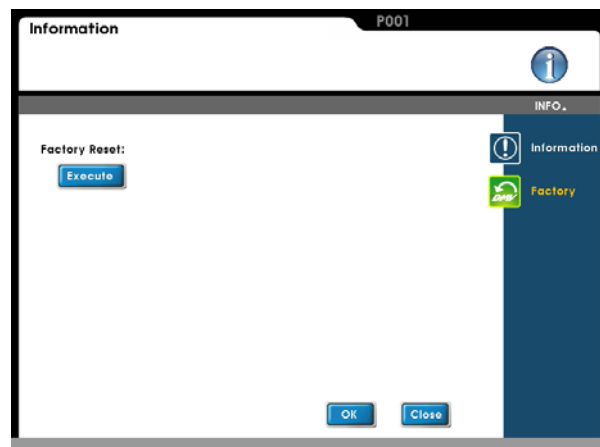

Chapter 6

Inspection Setting

6.1 Window Functionality

The main visual items to detect are "quantity", "defects", "coordinates", and "size." The VIS100 includes detection functions to meet a variety of custom requirements. In real-world applications, a reliable inspection system commonly depends on a combination of detection functions rather than a single detection function. For example, the system must determine the coordinates of an object in motion before measuring the size. This is a mixed combination of "coordinates" and "size."

Pay attention to the characteristics and targets of the items to be detected before designing the system, as the length of time for processing of each item may vary. Choosing the optimal function not only improves system reliability, but also decreases the detection cycle and so improves productivity.

6.1.1 Types of Inspection Windows

Detection function	Description
Area	Counts the number of black/white binarized pixels in the window.
Position	Finds a specific edge where the grayscale gradient exceeds the threshold in a grayscale image.
Count	Finds the number of edges where the grayscale gradient exceeds the threshold in a grayscale image.
Width	Finds the distance between two edges where the grayscale gradient exceeds the threshold in a grayscale image.
Pitch	Finds all edges where the grayscale gradient exceeds the threshold in a grayscale image, and then calculates the maximum and minimum width between each edge.
Angle	Calculates the angle between two edges where the grayscale gradient exceeds the threshold in two areas of a grayscale image.
Match pattern	Finds the coordinates and angle of a pattern in a designated window referenced to the sample pattern.
Blob	Counts the number of clusters of black/white pixels in the window and then calculates the coordinates and center of weight of each cluster.
Intensity	Calculates the mean of all the grayscale pixels in window.
Position Trace	Finds all edges where the grayscale gradient exceeds the threshold in a grayscale image.
Width Trace	Finds all distances between two edges where the grayscale gradient exceeds the

	threshold in a grayscale image.
Mark	Marks a line, pattern, or text on the detection function result screen.

Sections 6.2–6.10 describe each detection function in further detail.

6.2 Area

6.2.1 What defines the [Area]?

The purpose of the Area function is to measure the number of black or white pixels in the specified window. Because the camera image has 256 gray levels (0–255), it function first binarizes the image into pure black and pure white pixels before measuring the area. The result is OK if the number of pixels falls in designated range; otherwise, the result is NG.

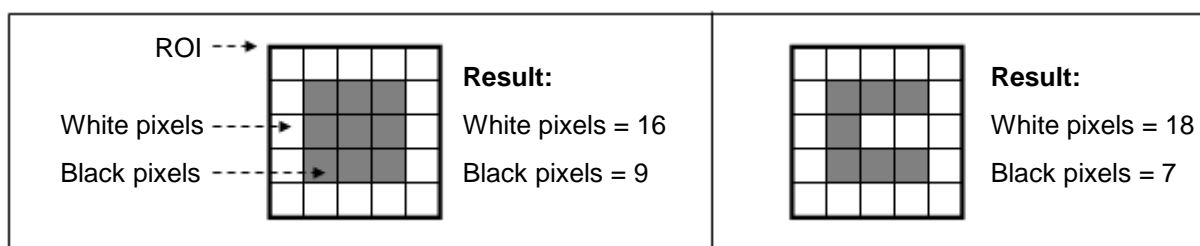

6.2.2 Detection Result

Area output report

■ "Value" Output

- Number of black/white pixels
For a 0.30 megapixel camera: 0–307,200 (640*480)
For a 0.80 megapixel camera: 0–786,432 (1024*768)

■ "Logic output (OK/NG)"

- The pixel count is OK = 1 if it is in the [Limit] range; otherwise the result is NG = 0.

6.2.3 Example Application of [Area]

The following picture shows the Area function checking the 7-segment display for defective LED segments and decimal points.

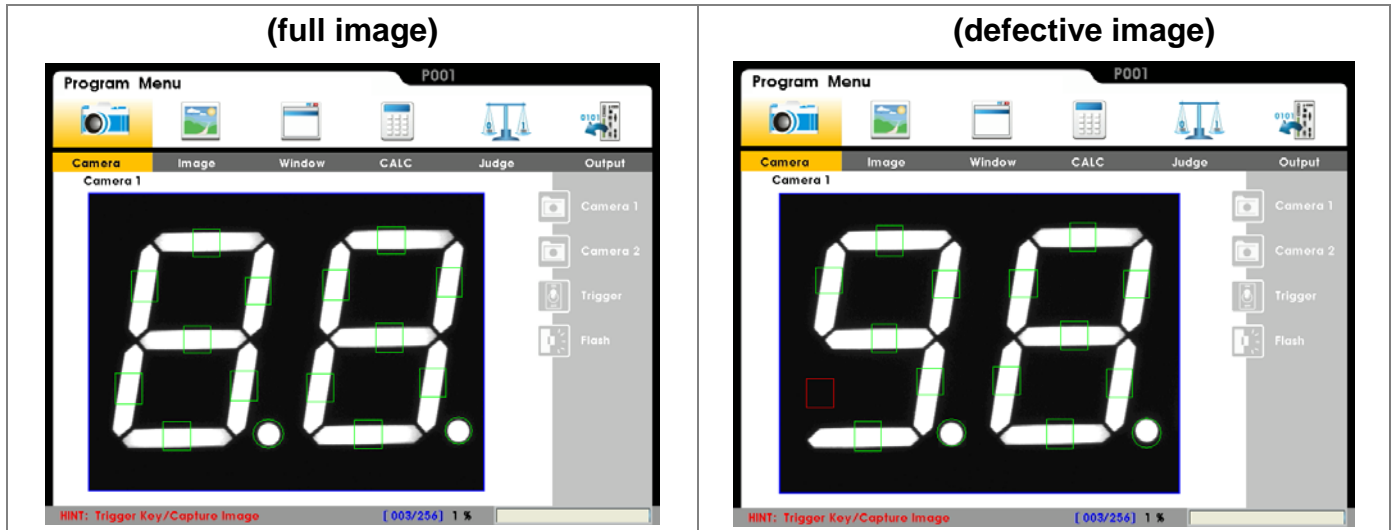

■ Detection method:

Individually detects the area for each LED segment. If the LED is properly lit, the white pixel count exceeds an acceptable range and the detection result is OK. If the LED is defective then the white pixel count is insufficient and the detection result is NG.

6.2.4 Set up [Area] settings

- From [Select Function], select the [Area] detection function.

Select [Edit] or [New].

Set up the following items in this sequence: [Source], [Preprocess], [ROI], [Parameter], [Limit], [Coordinate], and [Execute].

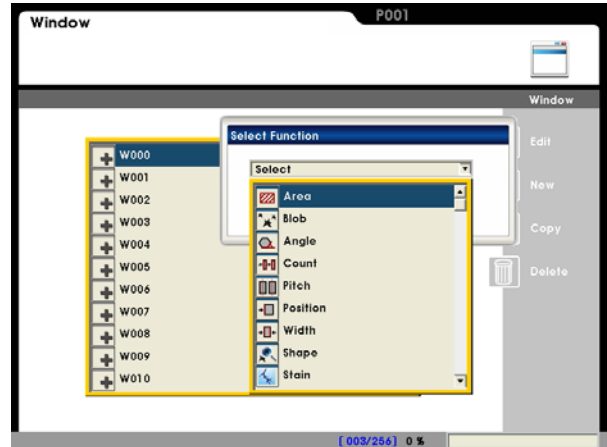

- Item 1: [Source]

Select camera

The system supports up to two cameras simultaneously. Select Camera 1 or Camera 2 for this detection.

Select image

Select a pre-captured image as the reference sample for this detection.

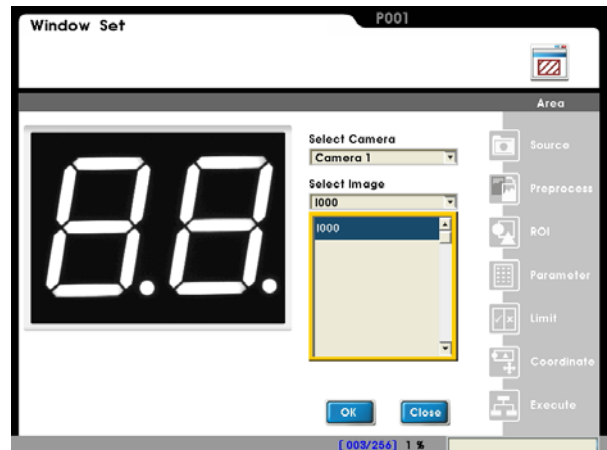

- Item 2: [Preprocess]

Use a software filter to first enhance the image to better meet the requirements. An appropriate preprocess filter can improve inspection accuracy and reliability.

The system includes more than a dozen preprocess filters, including binarization, dilation, and erosion.

You can apply up to six preprocess filters (numbered 1–6) in order.

Reference For more information about preprocess, refer to Chapter 11.



■ **Item 3: [ROI]**

ROI

Use the ROI to define a smaller area that covers fewer black/white pixels so that less time is required for the detection.

You can draw different measurement window shapes, including rectangles, ellipses, polygons, and circles.

 **Reference** Refer to Section 3.2 [Draw ROI (Region Of Interest)].

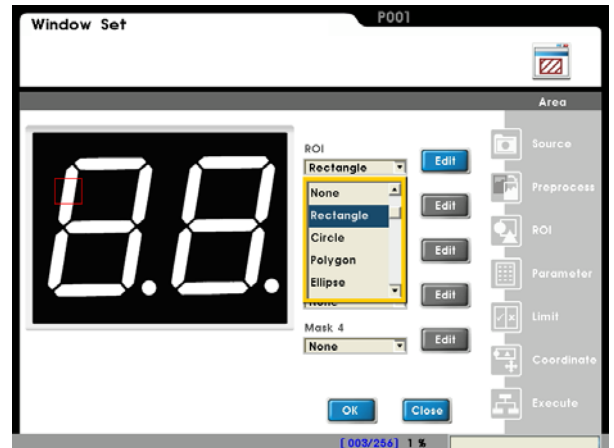

Mask 1–Mask 4

The mask is the area to exclude from measurement. You can set a mask in the [ROI] to exclude an area from detection.

In the example to the right, the red circle is a mask.

Each [Window] program supports up to four masks.

You can draw different mask shapes, such as rectangles, ellipses, polygons, and circles.

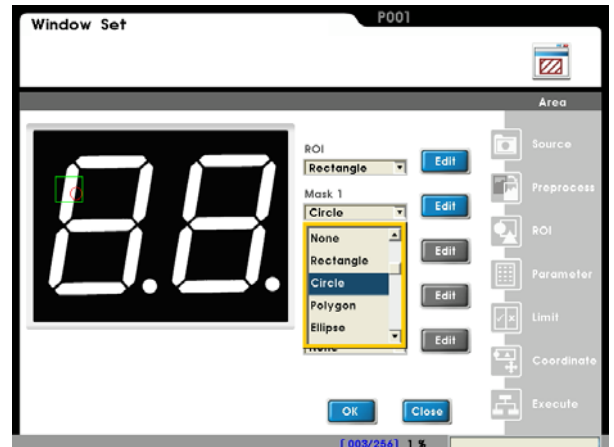

■ **Item 4: [Parameter]**

Binarization

The function binarizes the grayscale image into black and white pixels for area inspection.

Detect Object

Count the black pixels or the white pixels.

Origin

Define the position of the origin.

 **Reference** For more information about binarization, refer to Chapter 11.

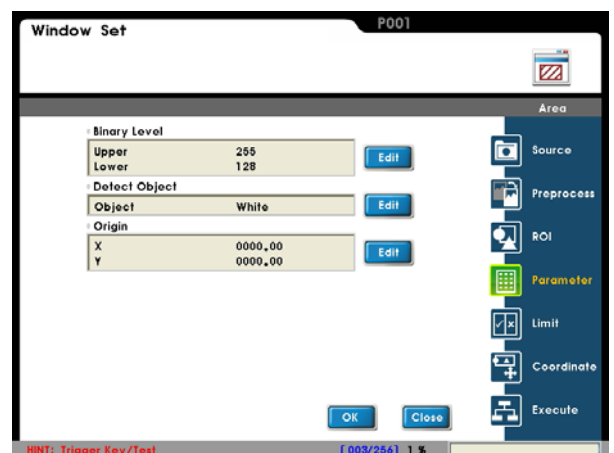

Set up binarization

Select [Edit] and adjust the upper/lower limits. The resulting image changes dynamically.

White pixels indicate the grayscale image inside the ROI, and black pixels are outside the area.

The grayscale level histogram is in the lower left of the screen.

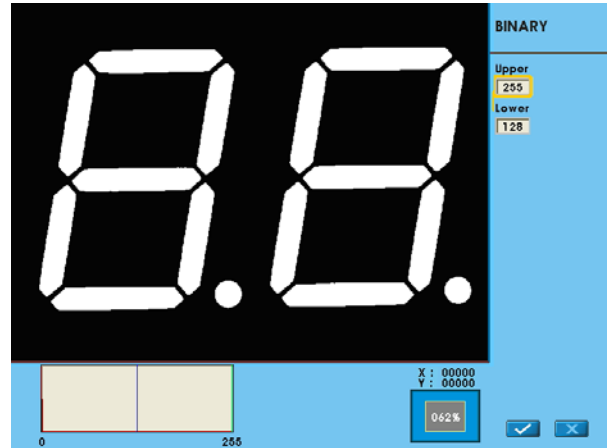

Set up origin

Select [Edit] to open the Origin Menu.

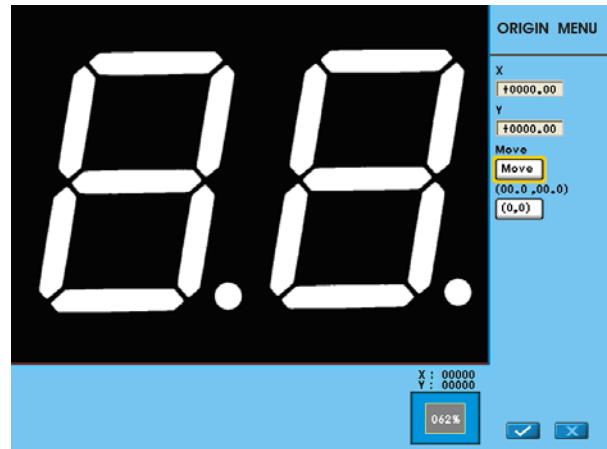

■ Item 5: [Limit]

Set the range for OK/NG detection. The result is OK if in the limit and NG otherwise.

The factory default setting is the maximum range and so the result is 1 (OK).

The system can pass this logic output result of OK = 1 and NG = 0 to the subsequent [Judge] program.

Reference Refer to Chapter 7 for a detailed description of [Judge].



■ Item 6: [Coordinate]

Specify whether to adjust the coordinates (X/Y) and angle (Theta) to match the [Window] result in the [ROI] window. As shown to the right, the [Shape] detection results automatically adjust the window X/Y/θ parameters. You can configure the [ROI] and [Mask 1]–[Mask 4] for the detection window.

 **Reference** For more information on coordinates, refer to Section 6.9.



■ Item 7: [Execute]

Execute or disable the [Window] function.

[Always Execute]: Always execute the current [Window] while running.

[Never Execute]: Never execute the current [Window] while running. This is useful during initial testing.

[Reference Execute]: Set the [Reference Window Item] and [Execute Condition] for flow control. Execution of [Window] is determined by the OK/NG results of the prior inspections.



6.3 Position

6.3.1 What is [Position]?

The Position function finds where the grayscale gradient satisfies the threshold. If the threshold is satisfied, that position is determined to be the ending position; the X/Y coordinates are calculated and the result is OK. If the grayscale gradient does not satisfy the threshold in the ROI, the result is NG.

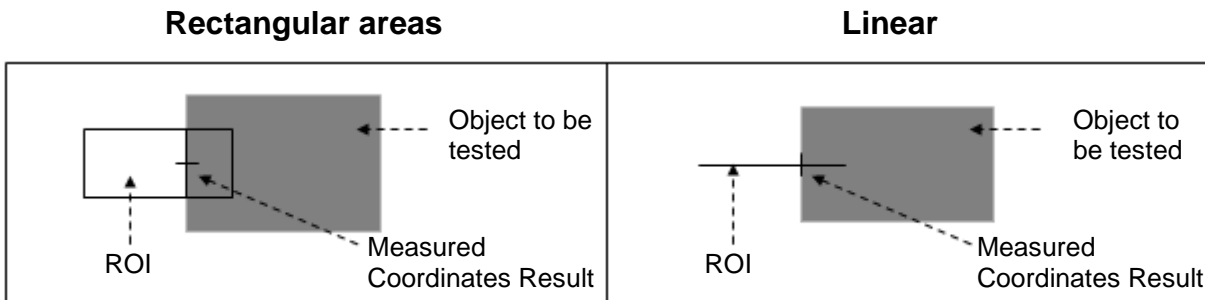

6.3.2 Detection Result

Position output report

■ "Value" Output

- For a 0.30 megapixel camera: (640*480)
X (horizontal) coordinates: 0–639
Y (vertical) coordinates: 0–479
- For a 0.80 megapixel camera: (1024*768)
X (horizontal) coordinates: 0–1023
Y (vertical) coordinates: 0–767

■ "Logic output (OK/NG)"

- Detection result
A successful detection is 1 = OK; otherwise the result is 0 = NG.
- X (horizontal) coordinates: When used with [Limit], the detection result is OK = 1 if in the limit; otherwise it is NG = 0.
- Y (vertical) coordinates: When used with [Limit], the detection result is OK = 1 if in the limit; otherwise it is NG = 0.

6.3.3 Example application of [Position]

The following picture show the object position offset of detection.

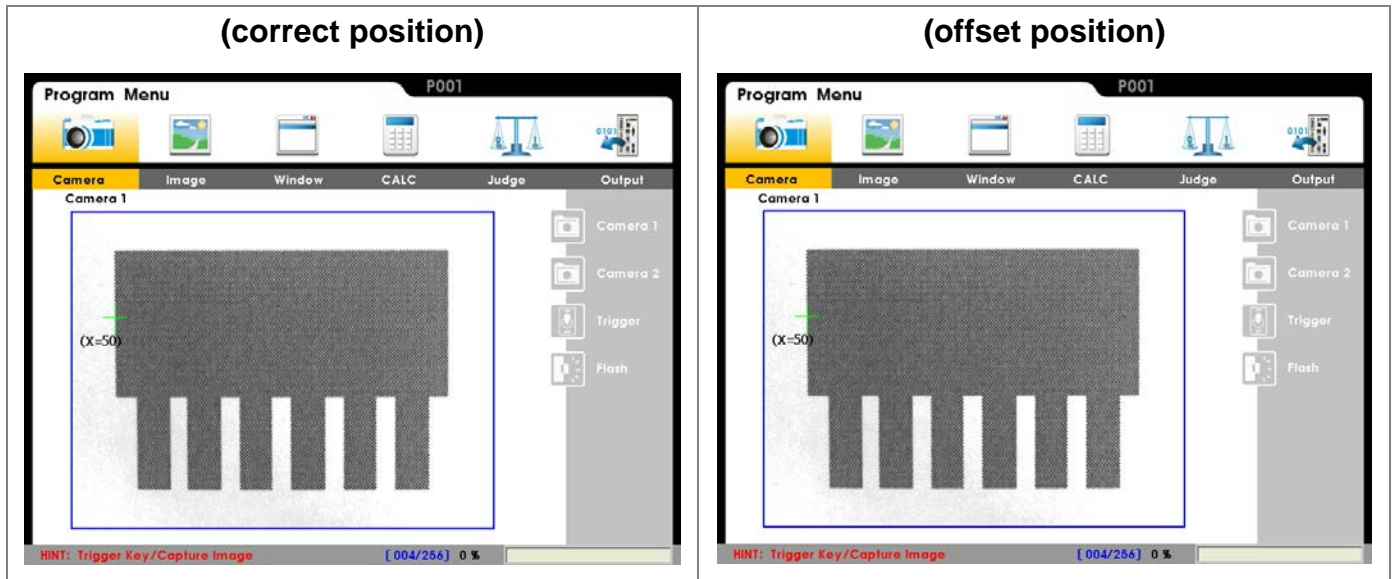

■ Detection method

Edge scan in the X-axis from left to right in the image. The detection result is OK if the X coordinates fall in the limit range; otherwise, the detection result is NG if it exceeds the limit range because the position offset is too large.

The system can pass the detected Position XY coordinates to subsequent programs as reference.

6.3.4 Setup [Position]

- From [Select Function], select the [Position] detection function.

Select [Edit] or [New].

Set up the following items in this sequence: [Source], [Preprocess], [ROI], [Parameter], [Limit], [Coordinate], and [Execute].

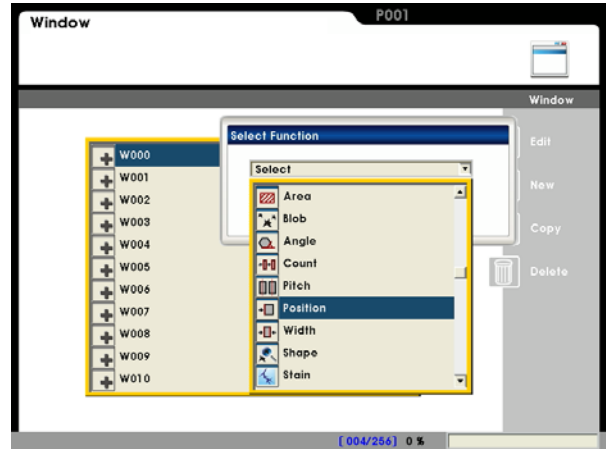

- Item 1: [Source]

Select camera

The system supports up to two cameras simultaneously. Select Camera 1 or Camera 2 for this detection.

Select image

Select a pre-captured image as the reference sample for this detection.

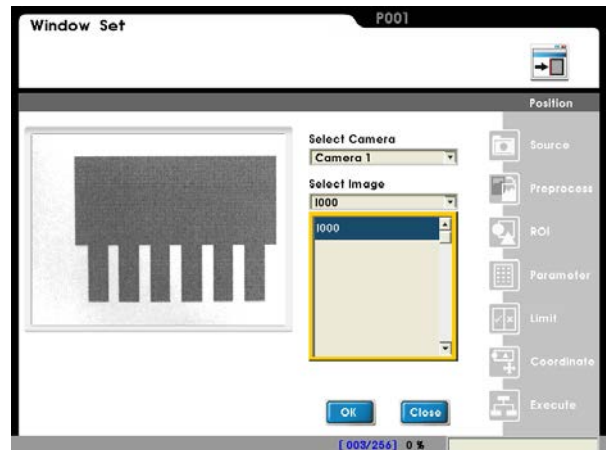

- Item 2: [Preprocess]

Use a software filter to first enhance the image to better meet the requirements. An appropriate preprocess filter can improve inspection accuracy and reliability.

The system includes more than a dozen preprocess filters, including binarization, dilation, and erosion.

You can apply up to six preprocess filters (numbered 1–6) in order.

Reference For more information about preprocess, refer to Chapter 11.

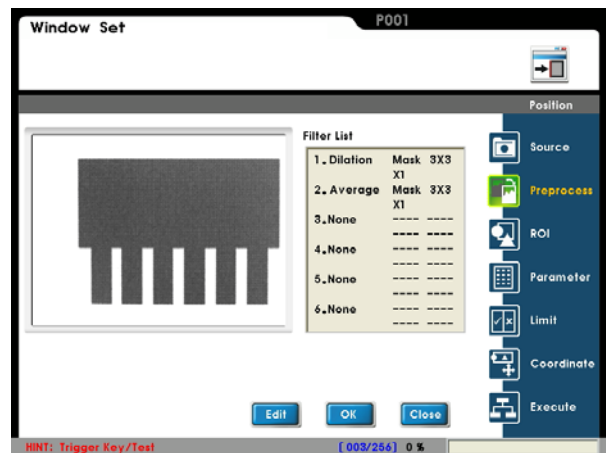

■ **Item 3: [ROI]**

ROI

Set the ROI for edge detection.

You can draw different measurement window shapes including rectangles, ellipses, polygons, and circles.

 **Reference** Refer to Section 3.2 [Draw ROI (Region of Interest)].

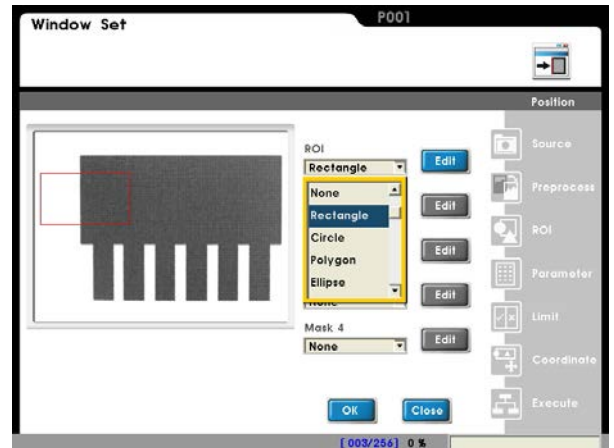

Mask 1–Mask 4

The mask is the area to exclude from measurement. You can set a mask in the [ROI] to exclude an area from detection.

In the example to the right, the red circle is a mask.

Each [Window] program supports up to four masks.

You can draw different mask shapes, such as rectangles, ellipses, polygons, and circles.

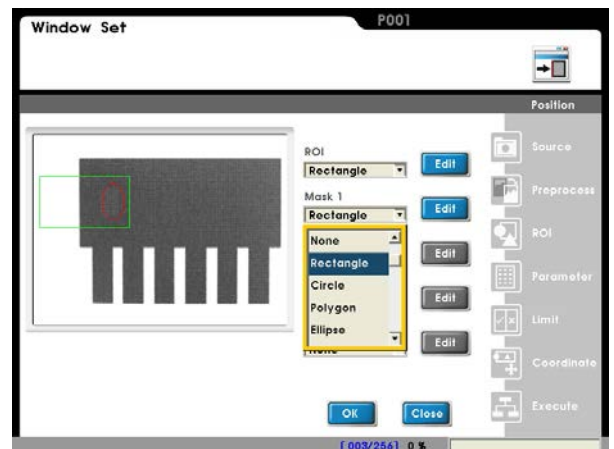

■ **Item 4: [Parameter]**

Edge filter

Set the direction for the detection search and edge filter parameters.

Examine the waveform to find the optimal parameter settings.

Origin

Define the position of the origin.

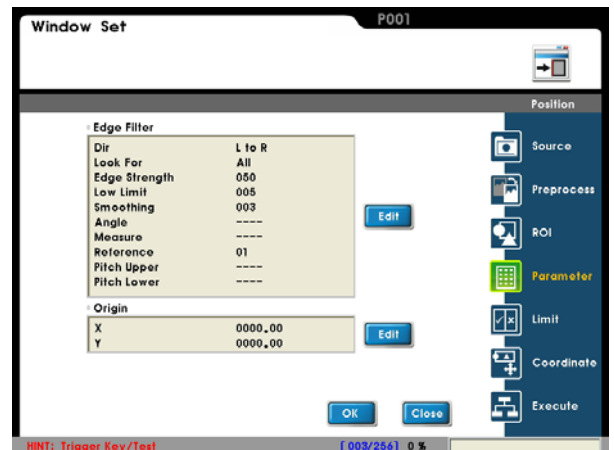

Set up origin

Select [Edit] to open the Origin Menu.

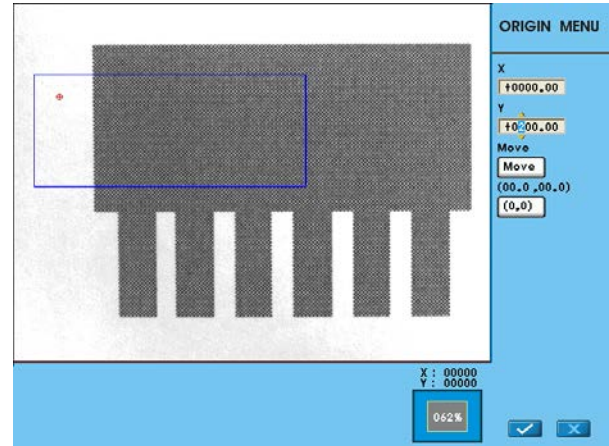

Item 5: [Limit]

Set the range for OK/NG detection. The result is OK if in the limit and NG otherwise.

The factory default setting is the maximum range and so the result is 1 (OK).

The system can pass this logic output result of OK = 1 and NG = 0 to the subsequent [Judge] program.

Reference Refer to Chapter 7 for a detailed description of [Judge].

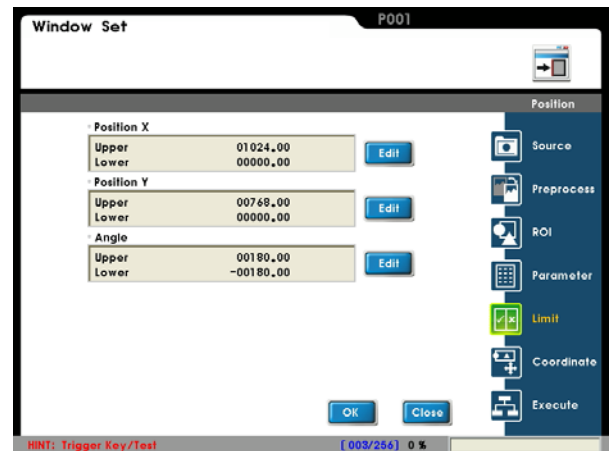

Item 6: [Coordinate]

Specify whether the function adjusts the coordinates (X/Y) and angle (Theta) to match the [Window] result in the [ROI] window. As shown to the right, the [Shape] detection results automatically adjust the window X/Y/θ parameters. You can configure the [ROI] and [Mask 1]–[Mask 4] for the detection window.

If you select [Capture], the system can pass the XY position coordinates to subsequent programs for reference.

Reference For more information on coordinates, refer to Section 6.9.

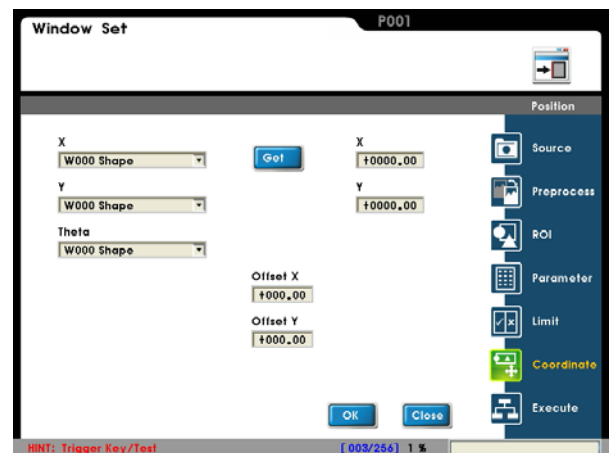

Item 7: [Execute]

Execute or disable the [Window] function.

[Always Execute]: Always execute the current [Window] while running.

[Never Execute]: Never execute the current [Window] while running. This is useful during initial testing.

[Reference Execute]: Set the [Reference Window Item] and [Execute Condition] for flow control. Execution of [Window] is determined by the OK/NG results of the prior inspections.



6.4 Count

6.4.1 What is [Count]?

The Count function counts the number of edges where the grayscale gradient exceeds the threshold in the image. The result is OK if edge the count satisfies the limit; otherwise the result is NG.

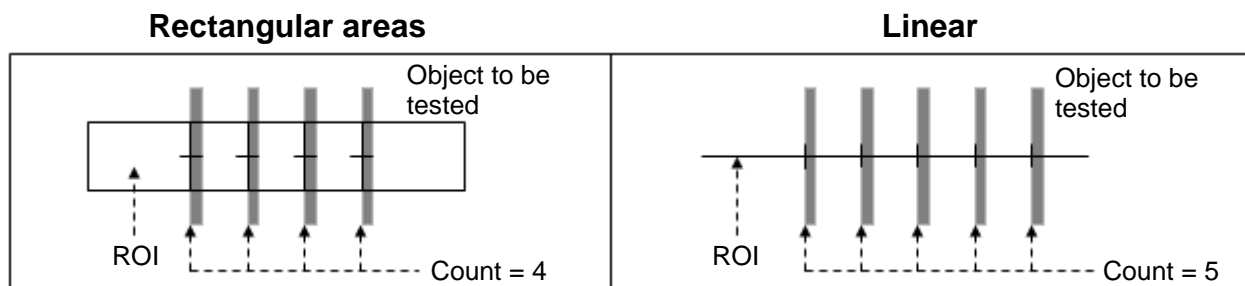

6.4.2 Detection Result

Count output report

■ "Value" Output

- Number of detected edges: Range: 0–999

■ "Logic output (OK/NG)"

- Edge count: When used with [Limit], the detection result is OK = 1 if within the limit; otherwise it is NG = 0.

6.4.3 Example application of [Count]

The following picture shows counting the number of detected terminals to ensure accuracy.

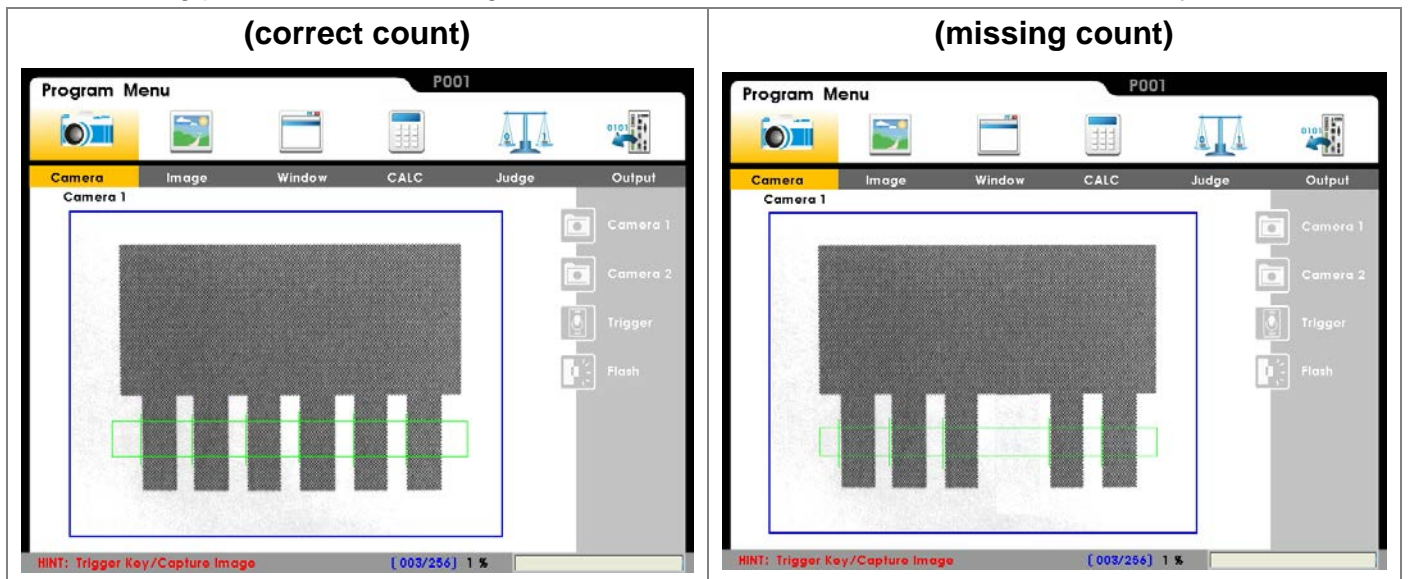

■ Detection method

The function calculates the number of terminals from the edge count. As shown above when used with a [Limit], the result is OK when edge count is 6; otherwise, the result is NG when the edge count is not 6.

6.4.4 Setup [Count]

- From [Select Function], select the [Position] detection function.

Select [Edit] or [New].

Set up the following items in this sequence: [Source], [Preprocess], [ROI], [Parameter], [Limit], [Coordinate], and [Execute].

- Item 1: [Source]

Select camera

The system supports up to two cameras simultaneously.

Select Camera 1 or Camera 2 for this detection.

Select image

Select a pre-captured image as the reference sample for this detection.

- Item 2: [Preprocess]

Use a software filter to first enhance the image to better meet the requirements. An appropriate preprocess filter can improve inspection accuracy and reliability.

The system includes more than a dozen preprocess filters, including binarization, dilation, and erosion.

You can apply up to six preprocess filters (numbered 1–6) in order.

 **Reference** For more information about preprocess, refer to Chapter 11.

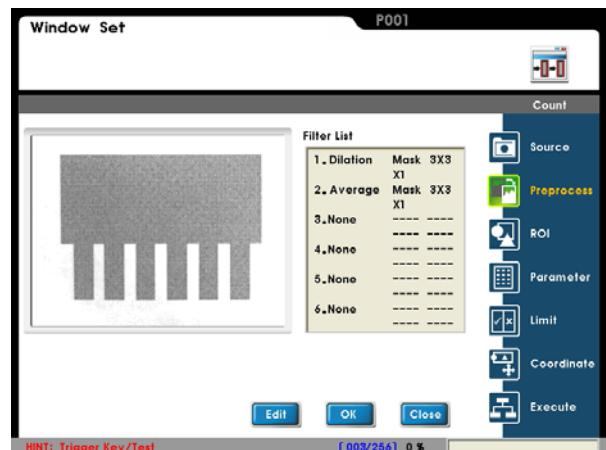
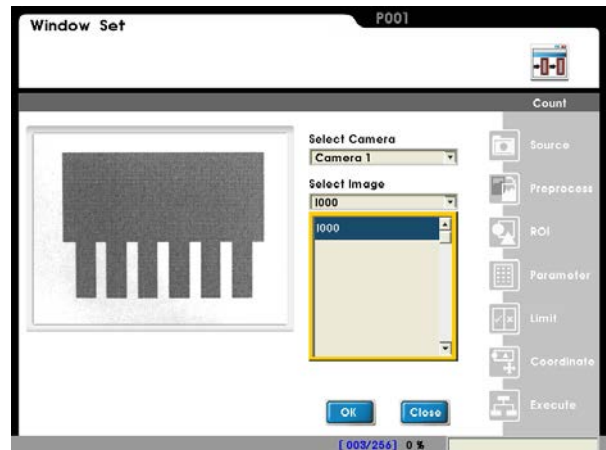
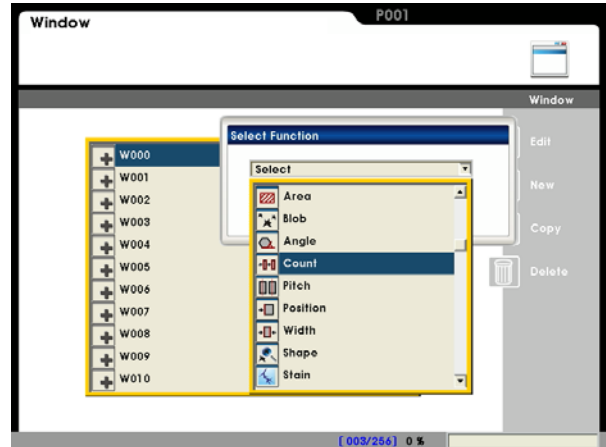

■ **Item 3: [ROI]**

ROI

Set the ROI for edge detection.

You can draw different measurement window shapes, including rectangles, ellipses, polygons, and circles.

 **Reference** Refer to Section 3.2 [Draw ROI (Region Of Interest)].

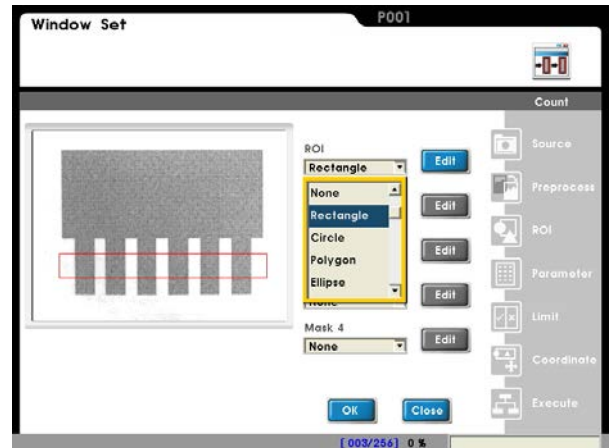

Mask 1–Mask 4

The mask is the area to exclude from measurement. You can set a mask in the [ROI] to exclude an area from detection.

In the example to the right, the red rectangle is a mask.

Each [Window] program supports up to four masks.

You can draw different mask shapes, such as rectangles, ellipses, polygons, and circles.

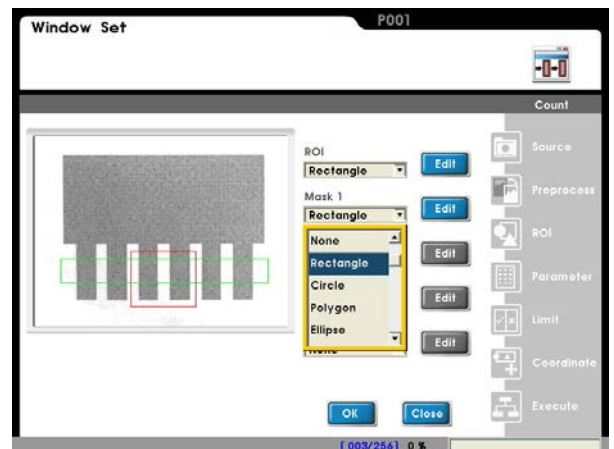

■ **Item 4: [Parameter]**

Edge filter

Set the direction for the detection search and edge filter parameters.

Examine the waveform to find the optimal parameter settings.

Origin

Define the position of the origin.

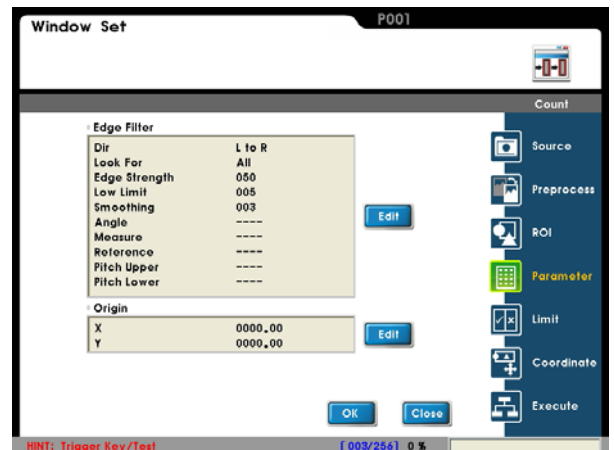

Chapter 6: Inspection Setting

Direction: Select the edge scanning direction.

Look For: Select the grayscale gradient type for the target edge.

Edge Strength: Set the target edge threshold (range: 0–100%)

Smoothing: Average out the edge strength to avoid false positives due to noise.

 **Reference** For more information about the Edge filter, refer to Section 10.2.

Set up origin

Select [Edit] to open the Origin Menu.

■ Item 5: [Limit]

Set the range for OK/NG detection. The result is OK if in the limit and NG otherwise.

The factory default setting is the maximum range and so the result is 1 (OK).

The system can pass this logic output result of OK = 1 and NG = 0 to the subsequent [Judge] program.

 **Reference** Refer to Chapter 7 for a detailed description of [Judge].

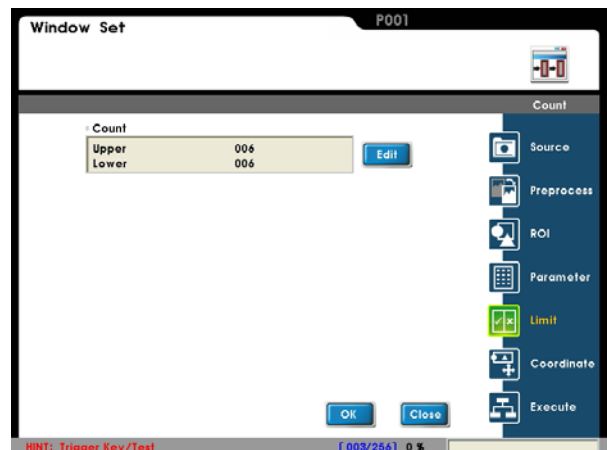
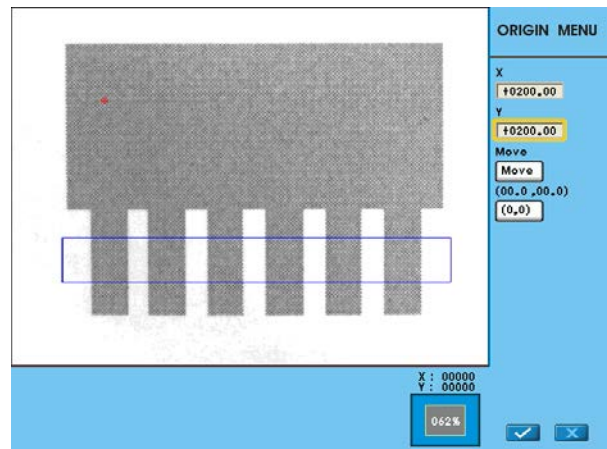
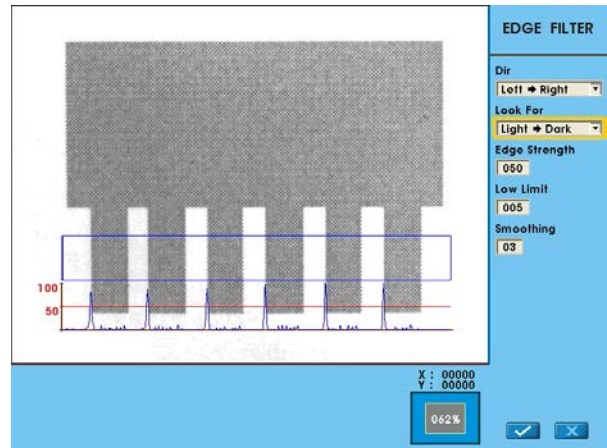

■ Item 6: [Coordinate]

Specify whether the function adjusts the coordinates (X/Y) and angle (Theta) to match the [Window] result in the [ROI] window. As shown to the right, the [Shape] detection results automatically adjust the window X/Y/θ parameters. You can configure the [ROI] and [Mask 1]–[Mask 4] for the detection window.

 **Reference** For more information on coordinates, refer to section 6.9.

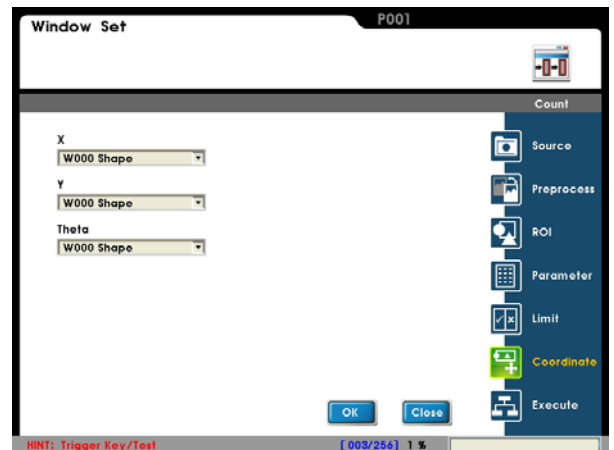

■ Item 7: [Execute]

Execute or disable the [Window] function.

[Always Execute]: Always execute the current [Window] while running.

[Never Execute]: Never execute the current [Window] while running. This is useful during initial testing.

[Reference Execute]: Set the [Reference Window Item] and [Execute Condition] for flow control. Execution of [Window] is determined by the OK/NG results of the prior inspections.



6.5 Width

6.5.1 What is [Width]?

The Width function determines the inner/outer edge-to-edge distance. The measurement result is OK if the width satisfies the limit; otherwise, the result is NG.

Outer edge measurement

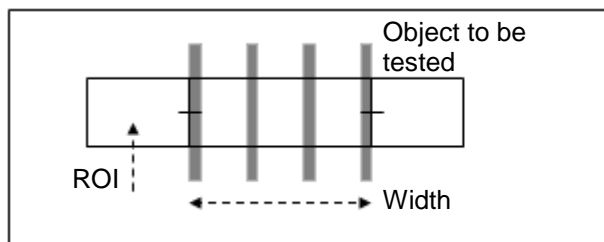

Inner edge measurement

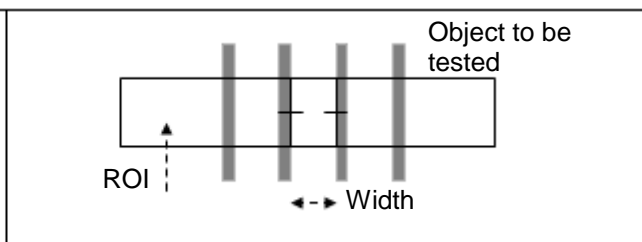

6.5.2 Detection Result

Width output report

■ "Value" Output

- Width found: Range: 0–9999
- Positions of first and second points:
 - For a 0.30 megapixel camera: X (horizontal) coordinates: 0–639
Y (vertical) coordinates: 0–479
 - For a 0.80 megapixel camera: X (horizontal) coordinates: 0–1023
Y (vertical) coordinates: 0–767

■ "Logic output (OK/NG)"

- Width: When used with [Limit], the detection result is OK = 1 if in the limit; otherwise it is NG = 0.

6.5.3 Example application of [Width]

The following picture shows measuring the inner or outer diameter of the O circle.

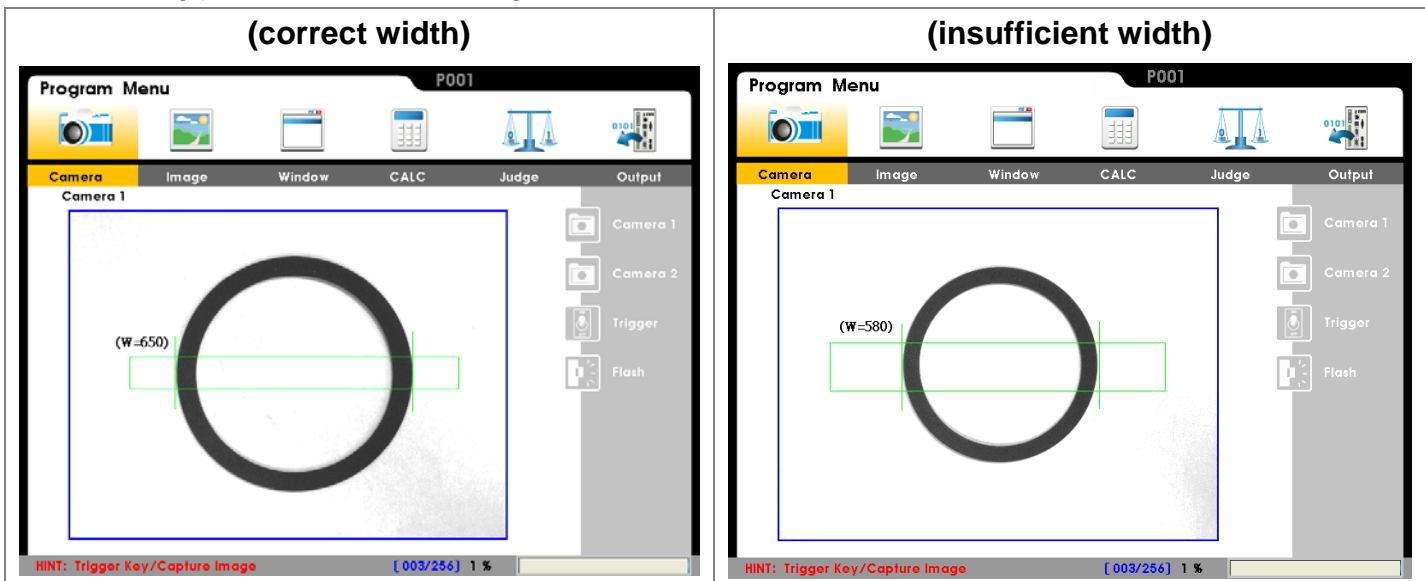

■ Detection method

The function measures the inner or outer diameter using the Width function. As shown above, the result is OK if the outer diameter satisfies the limit; otherwise, the result is NG.

6.5.4 Set up [Width] Detection

- From [Select Function], select the [Width] detection function

Select [Edit] or [New].

Set up the following items in this sequence: [Source], [Preprocess], [ROI], [Parameter], [Limit], [Coordinate], and [Execute].

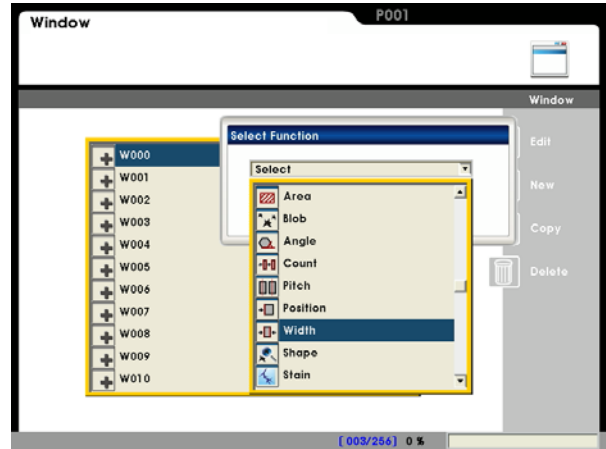

- Item 1: [Source]

Select camera

The system supports up to two cameras simultaneously. Select Camera 1 or Camera 2 for this detection.

Select image

Select a pre-captured image as the reference sample for this detection.

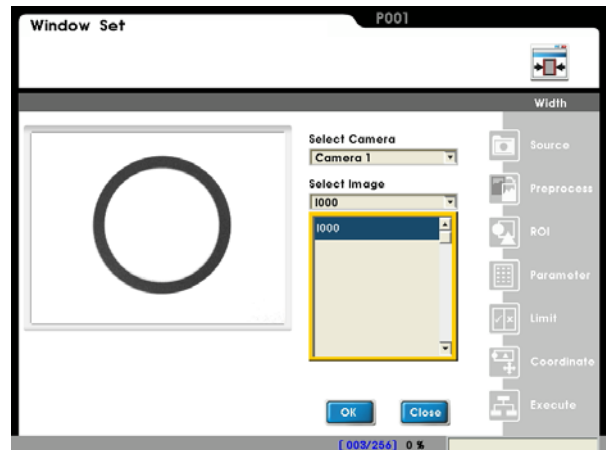

- Item 2: [Preprocess]

Use a software filter to first enhance the image to better meet the requirements. An appropriate preprocess filter can improve accuracy and reliability of the inspection.

The system includes more than a dozen preprocess filters, including binarization, dilation, and erosion.

You can apply up to six preprocess filters (numbered 1–6) in order.

Reference For more information about preprocess, refer to Chapter 11.

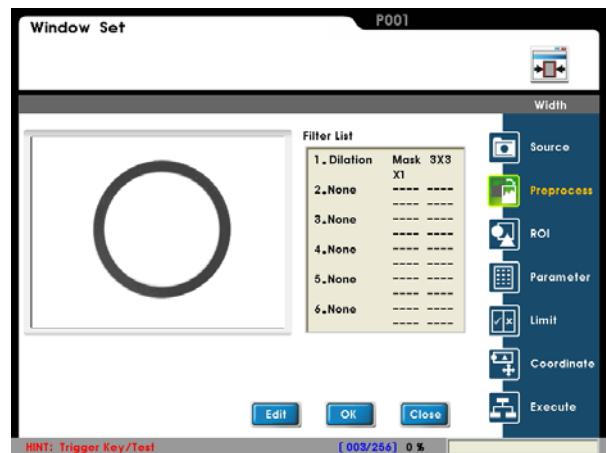

■ **Item 3: [ROI]**

ROI

Set the ROI for edge detection.

You can draw different measurement window shapes, including rectangles, ellipses, polygons, and circles.

Reference Refer to Section 3.2 [Draw ROI (Region Of Interest)].

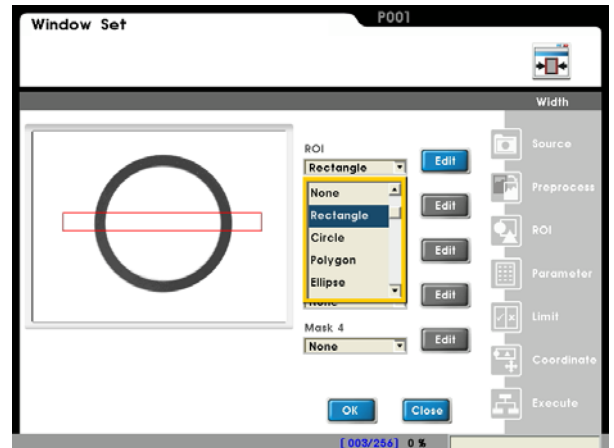

Mask 1–Mask 4

The mask is the area to exclude from measurement. You can set a mask in the [ROI] to exclude an area from detection.

In the example to the right, the red circle is a mask.

Each [Window] program supports up to four masks.

You can draw different mask shapes, such as rectangles, ellipses, polygons, and circles.

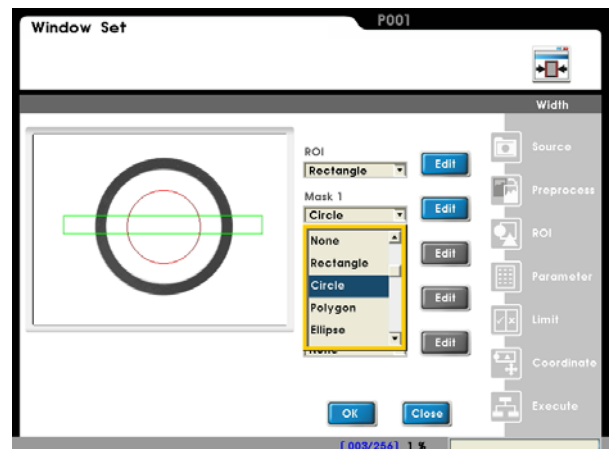

■ **Item 4: [Parameter]**

Edge filter

Set the direction for the detection search and edge filter parameters.

Examine the waveform to find the optimal parameter settings.

Origin

Define the position of the origin.

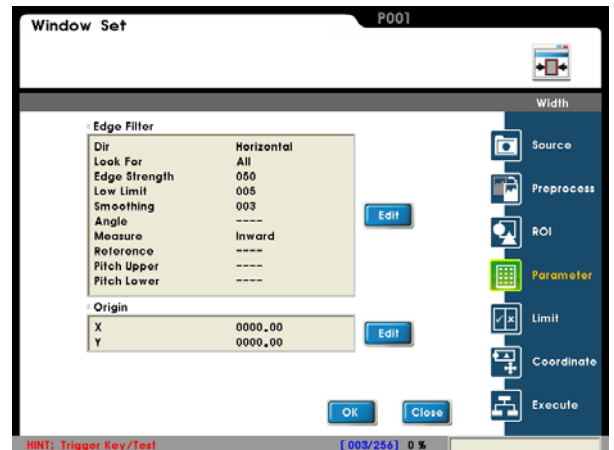

Set up origin

Select [Edit] to open the Origin Menu.

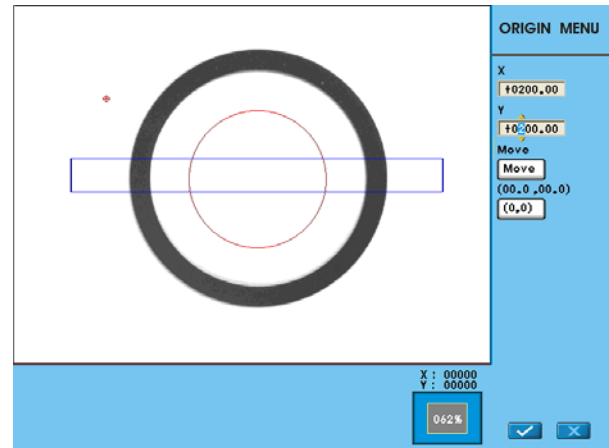

Item 5: [Limit]

Set the range for OK/NG detection. The result is OK if in the limit and NG otherwise.

The factory default setting is the maximum range and so the result is 1 (OK).

The system can pass this logic output result of OK = 1 and NG = 0 to the subsequent [Judge] program.

Reference Refer to Chapter 7 for a detailed description of [Judge].



Item 6: [Coordinate]

Specify whether the function adjusts the coordinates (X/Y) and angle (Theta) to match the [Window] result in the [ROI] window. As shown to the right, the [Shape] detection results automatically adjust the window X/Y/θ parameters. You can configure the [ROI] and [Mask 1]–[Mask 4] for the detection window.

Reference For more information on coordinates, refer to section 6.9.



Item 7: [Execute]

Execute or disable the [Window] function.

[Always Execute]: Always execute the current [Window] while running.

[Never Execute]: Never execute the current [Window] while running. This is useful during initial testing.

[Reference Execute]: Set the [Reference Window Item] and [Execute Condition] for flow control. Execution of [Window] is determined by the OK/NG results of the prior inspections.



6.6 Pitch

6.6.1 What is [Pitch]?

The Pitch function is an enhanced Width function described in the previous section, which can measure multiple widths measured instead of just between two edges. The function calculates the individual width, maximum width, minimum width, and average width.

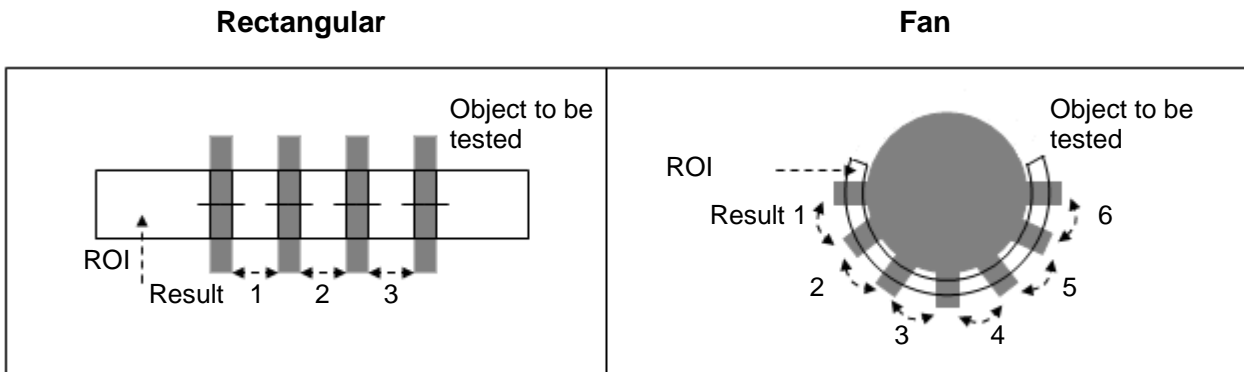

6.6.2 Detection Result

Pitch output report

■ "Value" Output

- Number of widths that fit the limit: Range: 0–999
- Designated Width: Range: 0–9999
- Max width: 0–9999
- Min width: 0–9999
- Average width: 0–9999
- Positions of first and second points:

For a 0.30 megapixel camera: X (horizontal) coordinates: 0–639

Y (vertical) coordinates: 0–479

For a 0.80 megapixel camera: X (horizontal) coordinates: 0–1023

Y (vertical) coordinates: 0–767

■ "Logic output (OK/NG)"

- Width count:
- Designated Width
- Maximum Width
- Minimum Width
- Average Width

When used with [Limit] for the above, the Detection result is OK = 1 if in the limit; otherwise it is NG = 0.

6.6.3 Example application of [Pitch]

The following picture show measuring the width of each terminal.

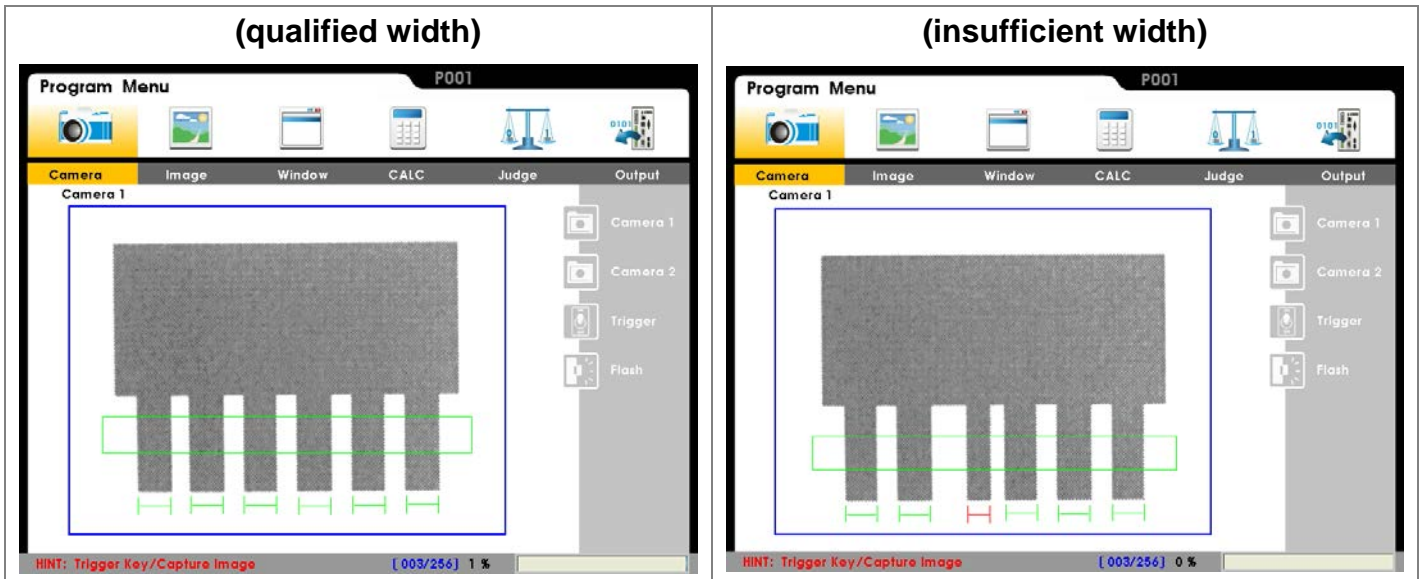

■ Detection method

The Pitch function automatically measures all terminal widths, and then filters out the results.

6.6.4 Setup [Pitch]

- From [Select Function], select the [Pitch] detection function.

Select [Edit] or [New].

Set up the following items in this sequence: [Source], [Preprocess], [ROI], [Parameter], [Limit], [Coordinate], and [Execute].

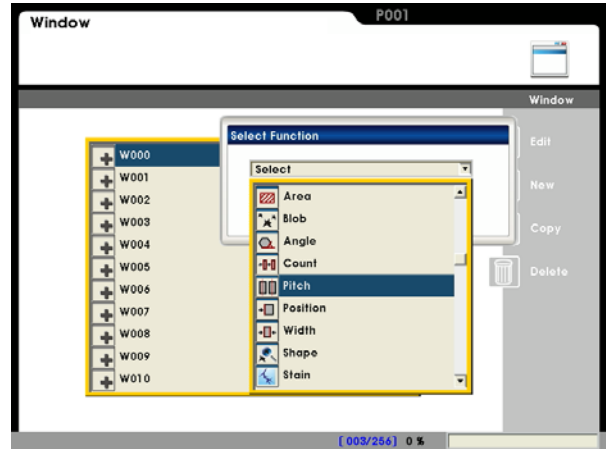

- Item 1: [Source]

Select camera

The system supports up to two cameras simultaneously.

Select Camera 1 or Camera 2 for this detection.

Select image

Select a pre-captured image as the reference sample for this detection.

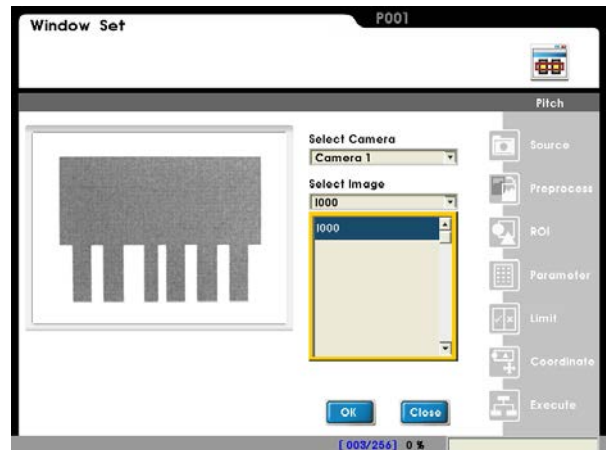

- Item 2: [Preprocess]

Use a software filter to first enhance the image to better meet the requirements. An appropriate preprocess filter can improve inspection accuracy and reliability.

The system includes more than a dozen preprocess filters, including binarization, dilation, and erosion.

You can apply up to six preprocess filters (numbered 1–6) in order.

 **Reference** For more information about preprocess, refer to Chapter 11.

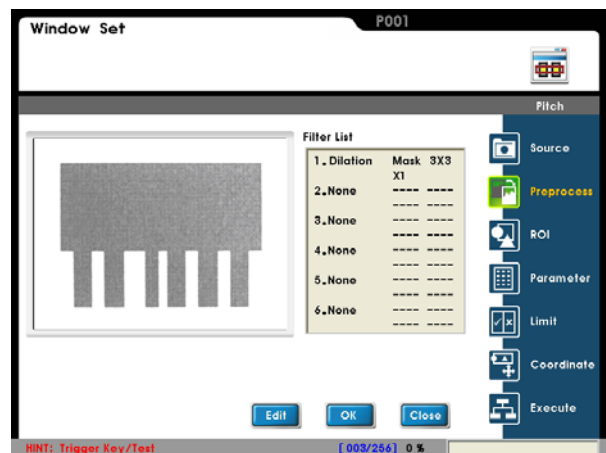

■ **Item 3: [ROI]**

ROI

Set the ROI for edge detection.

You can draw different measurement window shapes, including rectangles, ellipses, polygons, and circles.

Reference Refer to Section 3.2 [Draw ROI (Region of Interest)].

Mask 1–Mask 4

The mask is the area to exclude from measurement. You can set a mask in the [ROI] to exclude an area from detection.

In the example to the right, the small red rectangle is a mask.

Each [Window] program supports up to four masks.

You can draw different mask shapes, such as rectangles, ellipses, polygons, and circles.

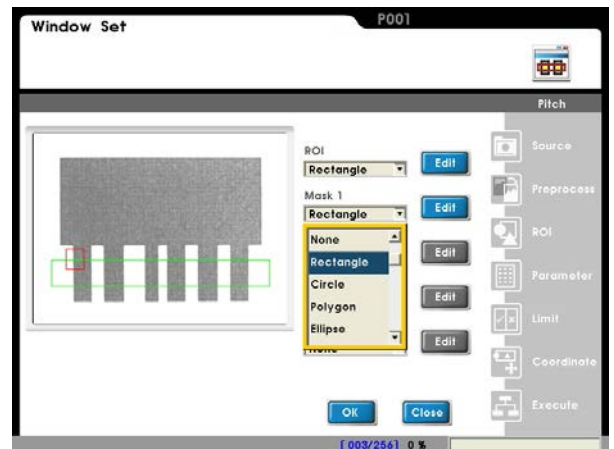
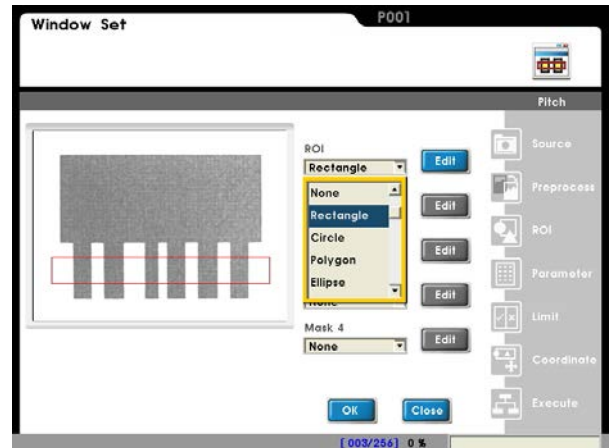

■ **Item 4: [Parameter]**

Edge filter:

Set the direction for the detection search and edge filter parameters.

Examine the waveform to find the optimal parameter settings.

Origin

Define the position of the origin.

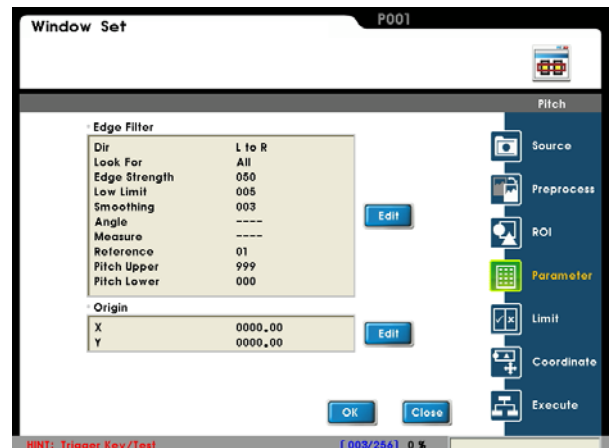

Set up origin

Select [Edit] to open the Origin Menu.

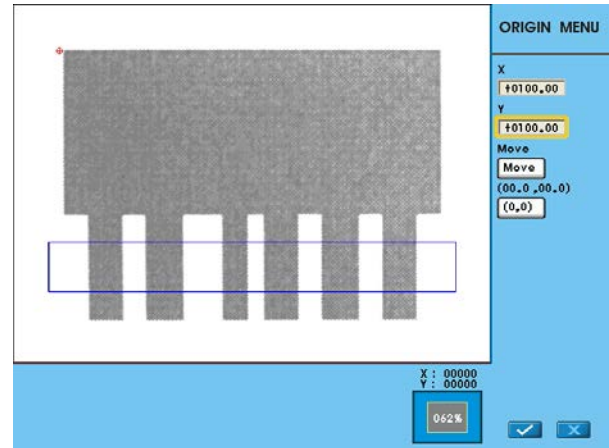

Item 5: [Limit]

Set the range for OK/NG detection. The result is OK if in the limit and NG otherwise.

The factory default setting is the maximum range and so the result is 1 (OK).

The system can pass this logic output result of OK = 1 and NG = 0 to the subsequent [Judge] program.

Reference Refer to Chapter 7 for a detailed description of [Judge].

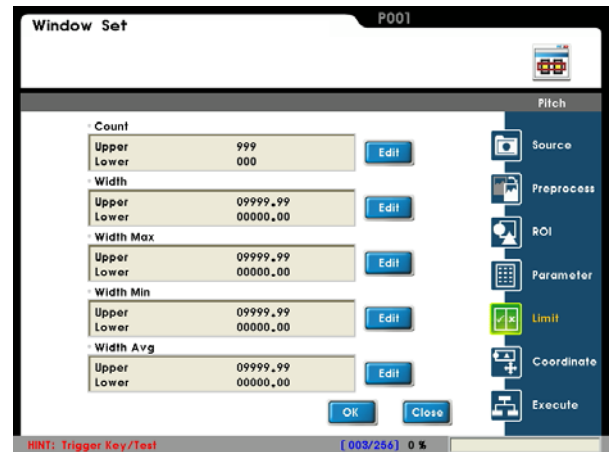

Item 6: [Coordinate]

Specify whether the function adjusts the coordinates (X/Y) and angle (Theta) to match the [Window] result in the [ROI] window. As shown to the right, the [Shape] detection results automatically adjust the window X/Y/θ parameters. You can configure the [ROI] and [Mask 1]–[Mask 4] for the detection window.

Reference For more information on coordinates, refer to section 6.9.



Item 7: [Execute]

Execute or disable the [Window] function.

[Always Execute]: Always execute the current [Window] while running.

[Never Execute]: Never execute the current [Window] while running. This is useful during initial testing.

[Reference Execute]: Set the [Reference Window Item] and [Execute Condition] for flow control. Execution of [Window] is determined by the OK/NG results of the prior inspections.

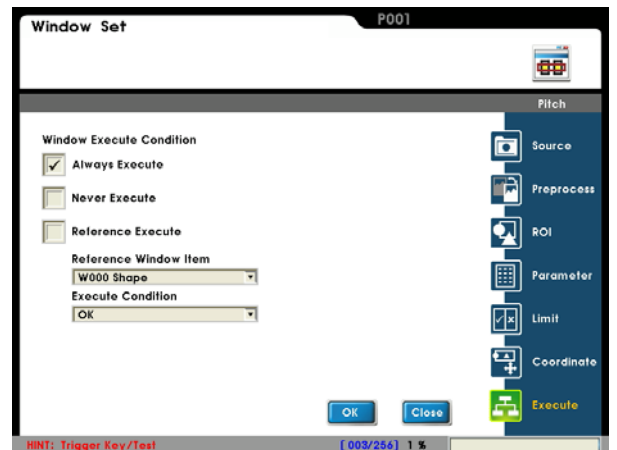

6.7 Angle

6.7.1 What is [Angle]?

The Angle function draws a line through two positions and calculates the angle of the line to the horizontal axis.

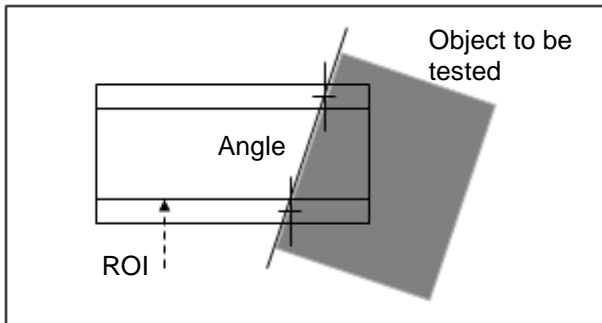

6.7.2 Detection Result

Angle output report

- **"Value" Output**
 - Angle found: Range: 0–360
- **"Logic output (OK/NG)"**
 - Angle: When used with [Limit], the detection result is OK = 1 if in the limit; otherwise it is NG = 0.

6.7.3 Example application of [Angle]

The following pictures show measuring the slant angle of the object from the horizontal.

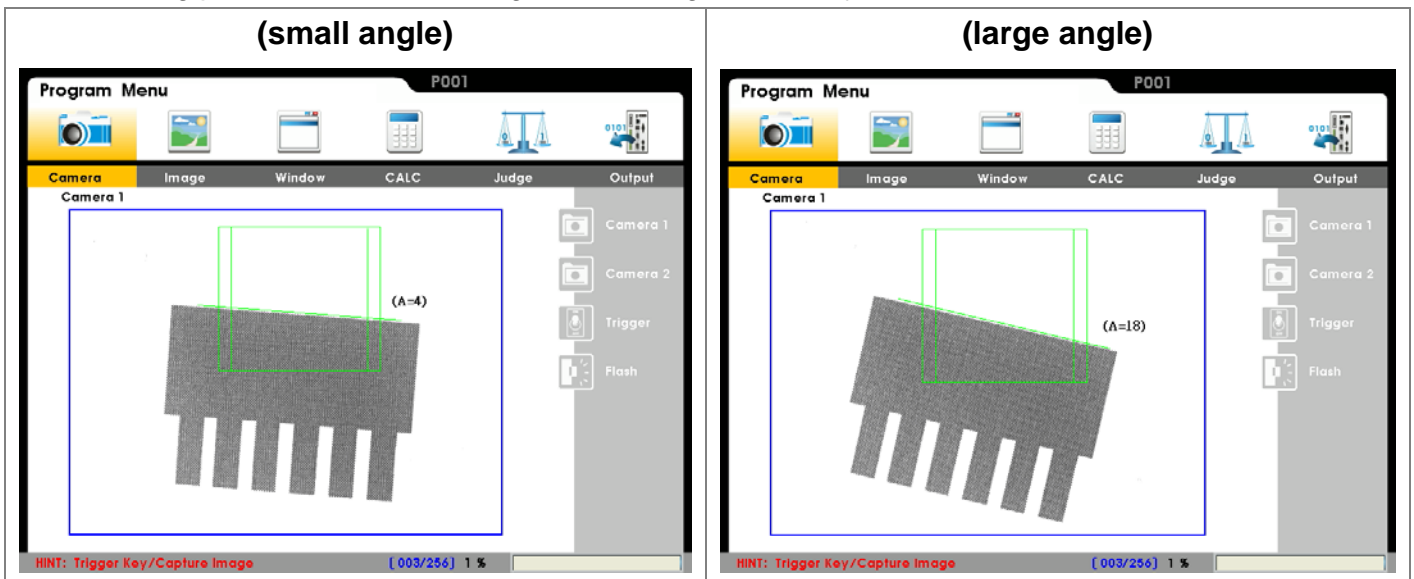

■ Detection method

The Angle function automatically determines two positions and calculates the angle of the line to the horizontal axis. The detection result is OK if the angular coordinates fall in the limit range. Otherwise, the detection result is NG if the angle exceeds the limit range because the position offset is too large. The system can pass the angle onto subsequent rotation functions as reference.

6.7.4 Set up [Angle] Detection

- From [Select Function], select the [Angle] detection function.

Select [Edit] or [New].

Set up the following items in this sequence: [Source], [Preprocess], [ROI], [Parameter], [Limit], [Coordinate], and [Execute].

- **Item 1: [Source]**

Select camera

The system supports up to two cameras simultaneously.

Select Camera 1 or Camera 2 for this detection.

Select image

Select a pre-captured image as the reference sample for this detection.

- **Item 2: [Preprocess]**

Use a software filter to first enhance the image to better meet the requirements. An appropriate preprocess filter can improve inspection accuracy and reliability.

The system includes more than a dozen preprocess filters, including binarization, dilation, and erosion.

You can apply up to six preprocess filters (numbered 1–6) in order.

Reference For more information about preprocess, refer to Chapter 11.

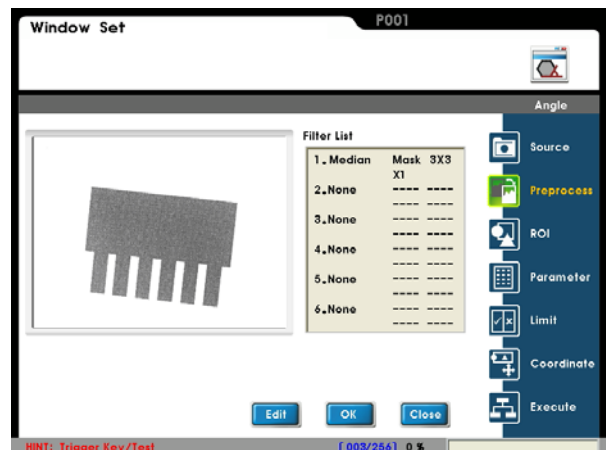
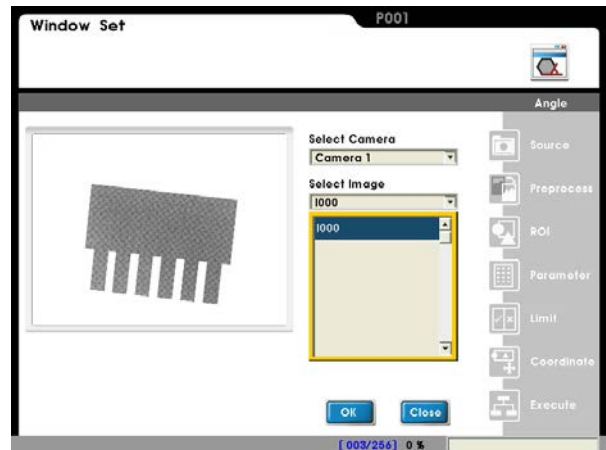
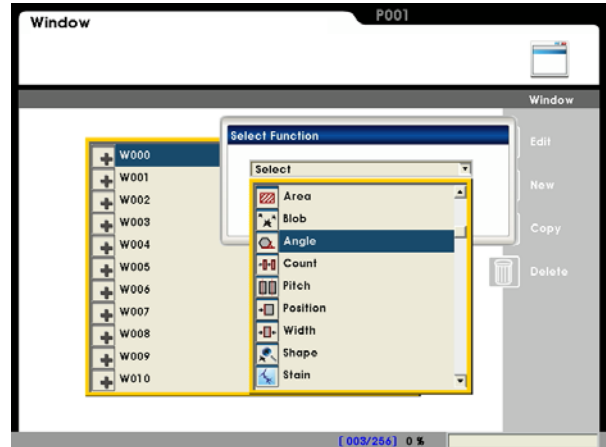

■ **Item 3: [ROI]**

ROI

Set the ROI for edge detection.

Angle is only available when using the Rectangle window ROI.

 **Reference** Refer to Section 3.2 [Draw ROI (Region of Interest)].

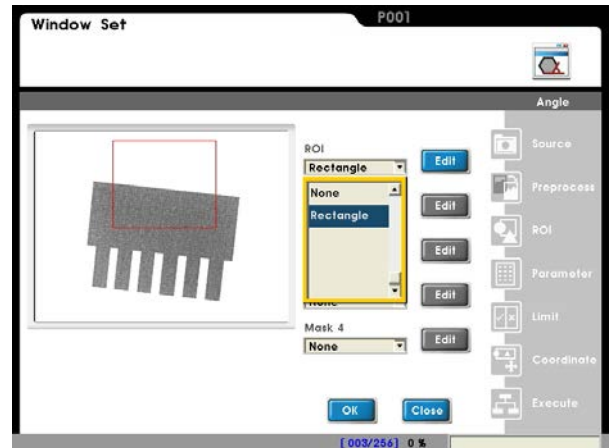

Mask 1–Mask 4

The mask is the area to exclude from measurement. You can set a mask in the [ROI] to exclude an area from detection.

In the example to the right, the red circle is a mask.

Each [Window] program supports up to four masks. You can draw different mask shapes, such as rectangles, ellipses, polygons, and circles.

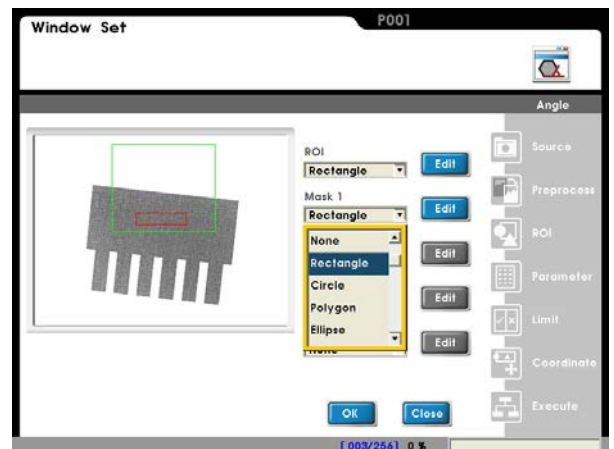

■ **Item 4: [Parameter]**

Edge filter

Set the direction for the detection search and edge filter parameters.

Examine the waveform to find the optimal parameter settings.

Origin

Define the position of the origin.

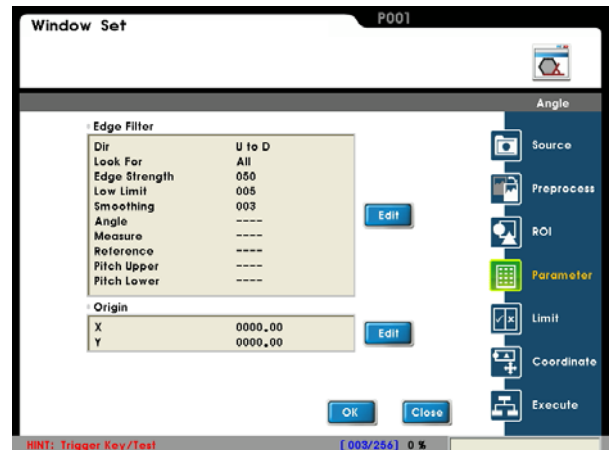

Set up origin

Select [Edit] to open the Origin Menu.

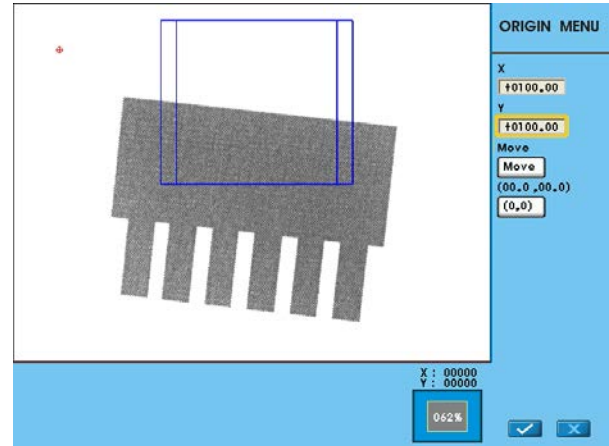

■ Item 5: [Limit]

Set the range for OK/NG detection. The result is OK if in the limit and NG otherwise.

The factory default setting is the maximum range and so the result is 1 (OK).

The system can pass this logic output result of OK = 1 and NG = 0 to the subsequent [Judge] program.

Reference Refer to Chapter 7 for a detailed description of [Judge].



■ Item 6: [Coordinate]

Specify whether the function adjusts the coordinates (X/Y) and angle (Theta) to match the [Window] result in the [ROI] window. As shown to the right, the [Shape] detection results automatically adjust the window X/Y/θ parameters. You can configure the [ROI] and [Mask 1]–[Mask 4] for the detection window.

Select [Capture] and the system can use the edge angle (Theta) as a reference for a subsequent rotation program.

Reference For more information on coordinates, refer to Section 6.9.

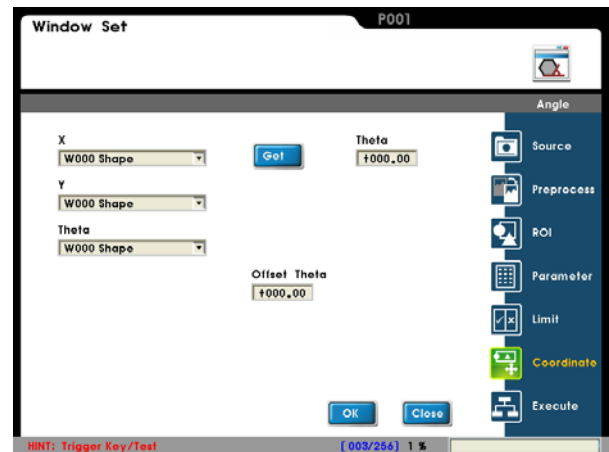

Item 7: [Execute]

Execute or disable the [Window] function.

[Always Execute]: Always execute the current [Window] while running.

[Never Execute]: Never execute the current [Window] while running. This is useful during initial testing.

[Reference Execute]: Set the [Reference Window Item] and [Execute Condition] for flow control. Execution of [Window] is determined by the OK/NG results of the prior inspections.



6.8 Pattern Comparison

6.8.1 What is [Pattern Comparison]

The Pattern Comparison function uses a reference image scanned from within the designated area to search for the specified shape based on pixels, and will output the XY coordinates and θ angle of the pattern located. Pattern Comparison is recommended for objects to be tested with offset positions. Then the XY θ parameters can be passed onto subsequent programs for offset calibration.

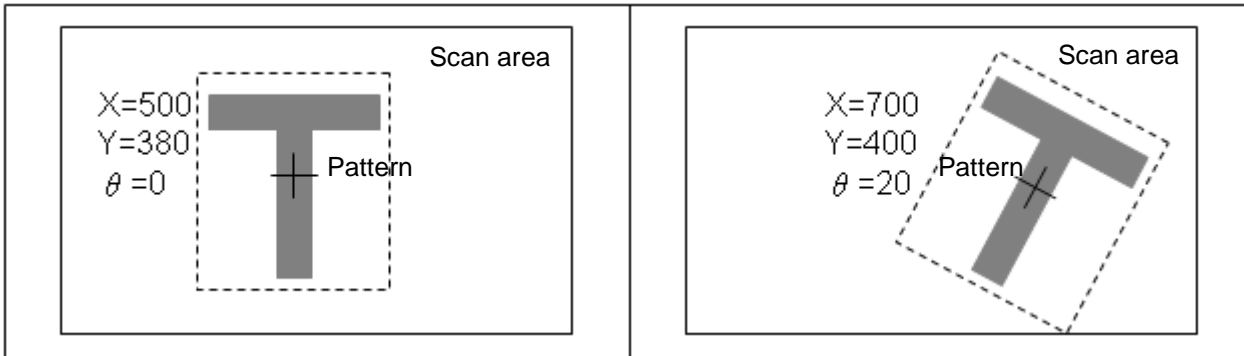

6.8.2 Detection Result

Pattern Comparison output report

■ "Value" Output

- Found: 0 - 999
- Similarity: 0 - 100.00
- θ (rotation) angle: -180.00~+180.00
- For a 0.3 megapixel camera: (640 x 480)
X (horizontal) coordinates: 0 - 639.99
Y (vertical) coordinates: 0 - 479.99
- For a 0.8 megapixel camera: (1024 x 768)
X (horizontal) coordinates: 0 - 1023.99
Y (vertical) coordinates: 0 - 767.99

■ "Logic output (OK/NG)"

- Detection result:
A successful detection is 1 = OK; otherwise the result is 0 = NG.
- Found: When used with [Limit], the detection result is OK=1 if within the limit; otherwise it will be NG=0.
- Similarity: When used with [Limit], the detection result is OK=1 if within the limit; otherwise it will be NG=0.

- θ (rotation) angle: When used with [Limit], the detection result is OK=1 if within the limit; otherwise it will be NG=0.
- X (horizontal) coordinates: When used with [Limit], the detection result is OK=1 if within the limit; otherwise it will be NG=0.
- Y (vertical) coordinates: When used with [Limit], the detection result is OK=1 if within the limit; otherwise it will be NG=0.

6.8.3 Example application of [Pattern Comparison]

As shown below, the offset XY θ of the object is passed onto subsequent [Count] as reference.

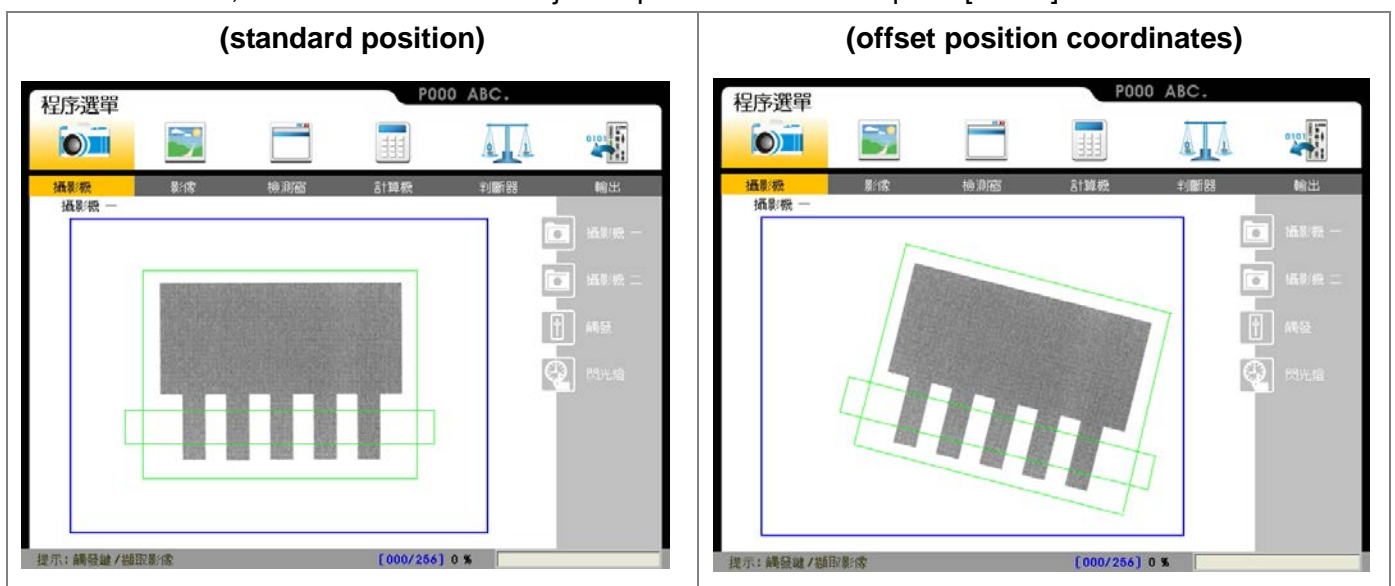

■ Inspection method

Both the pattern comparison (full rectangle) and count (flat rectangle) detection functions are applied to the standard captured image; at the same, position of the count is referenced to the pattern parameters. For more reliable results, the count detection frame offset matches the position offset of the test item.

6.8.4 [Pattern Comparison] Detection Settings

- Select the [Pattern Comparison] function from the [Inspection window] options.

Select [Edit] or [Add].

Set up the following items in sequence: [Source], [Pre-processing], [ROI], [Parameter], [Limit], [Coordinate], and [Execute].

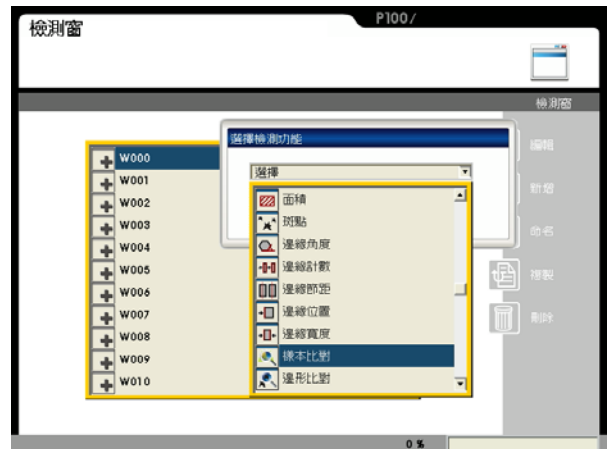

- Item 1: [Source]

Select camera:

Up to two cameras are supported simultaneously. Please select Camera 1 or Camera 2 for this detection.

Select image:

Select a pre-captured image as the reference sample for this detection.

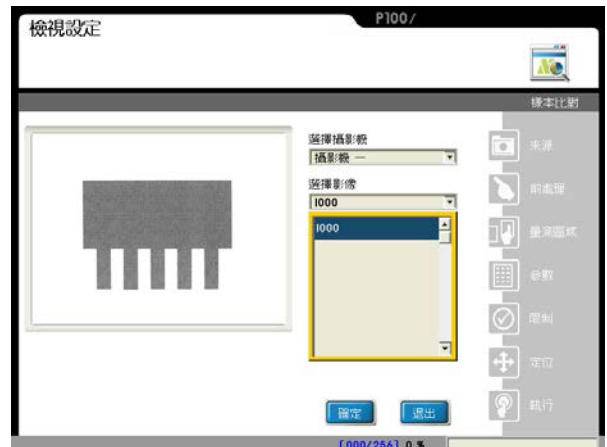

- Item 2: [Pre-processing]

A software filter is used to first enhance the image in order to better meet the requirements. An appropriate pre-processing filter can improve inspection accuracy and reliability.

More than a dozen pre-processing filters are provided, including binarization, expansion, erosion, etc.

Up to six pre-processing filters (numbered 1 - 6) can be applied in order.

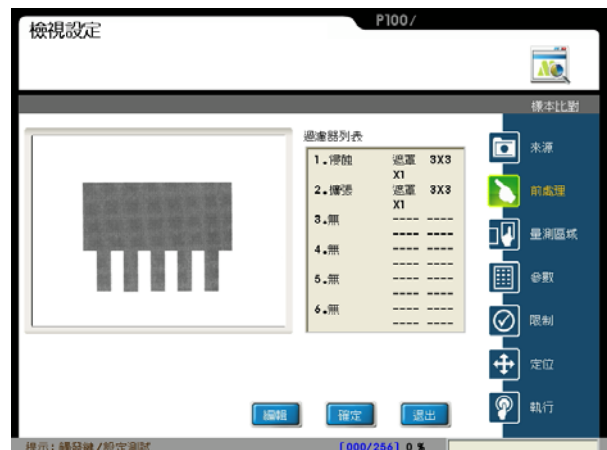

Reference Refer to Chapter 11 for more information about pre-processing.

Item 3: [ROI]

ROI:

Set the ROI for edge detection.

You can draw different measurement window shapes, including rectangles, circles, polygons, ellipses, rings, sectors and rotated rectangles.

Reference Refer to Section 3.2 [Draw ROI (Region Of Interest)].

Mask 1-Mask 4:

The mask is the area to be excluded from measurement. A mask can be set within the [ROI] to exclude an area from detection.

In the example to the right, the top left red rectangle is a mask.

Each [Inspection window] program supports up to four masks.

You can draw different mask shapes, such as rectangles, circles, polygons, ellipses, rings, sectors and rotated rectangles.

Item 4: [Parameter]

Pattern Comparison Settings:

Configure the quantity, accuracy, similarity, and angle tolerance of the search here.

Origin:

Define the position of the origin.

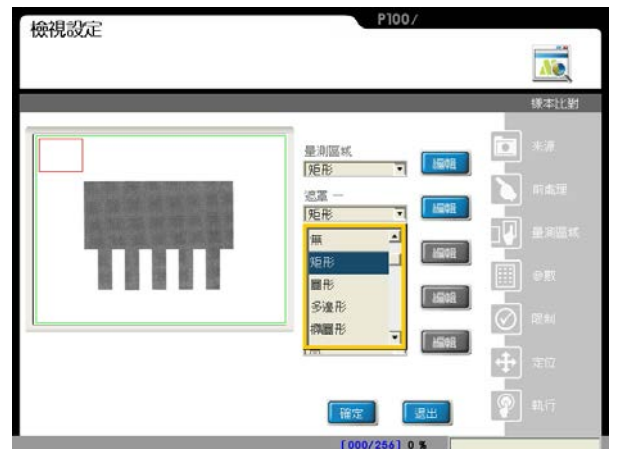
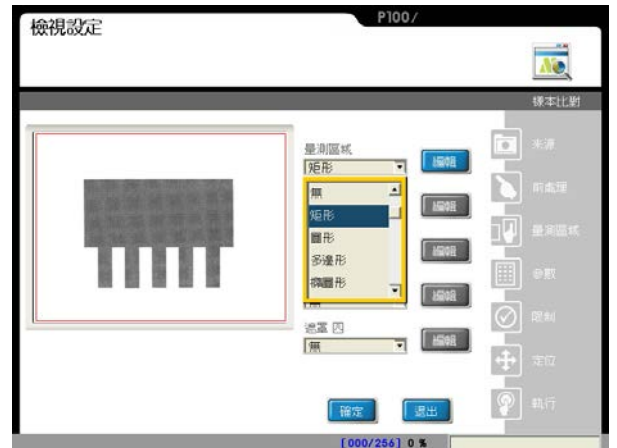

Chapter 6: Inspection Setting

Add Pattern:

Configure the pattern to search for. Since pattern comparison uses every pixel in the pattern as the basis for search, it is more suitable for complex patterns.

Select [Close] to finish setup.

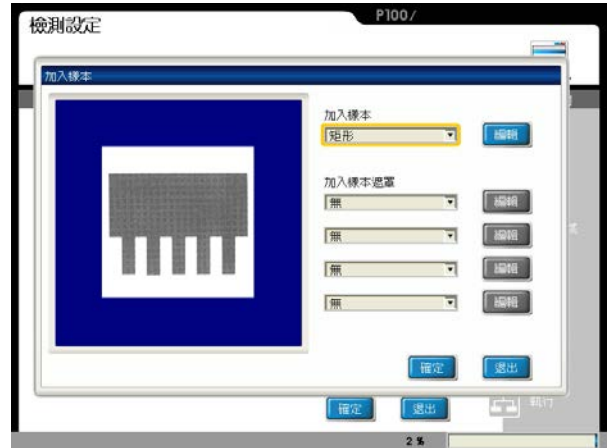

Angle: Set positive/negative angle range. (a value of 20 indicates -20~+20)

Similarity: Pattern matching and coordinates are successful if similarity is higher than the configured value.

Reference: Output the n-th result when scanning multiple targets. (must be used with the [Sort Rule] below)

Search Number: Adjust this quantity when scanning multiple targets. However, the scan time will increase if the target is less than the scan quantity.

Sort Rule: Set the sort method for multiple scanned targets. The n-th result from [Reference] will also be changed.

Accuracy: Higher accuracy results in more accurate XYθ parameters, but detection time is also increased.

Search method: Higher accuracy settings will result in more candidate points and more accurate XYθ parameters, but detection time is also increased.

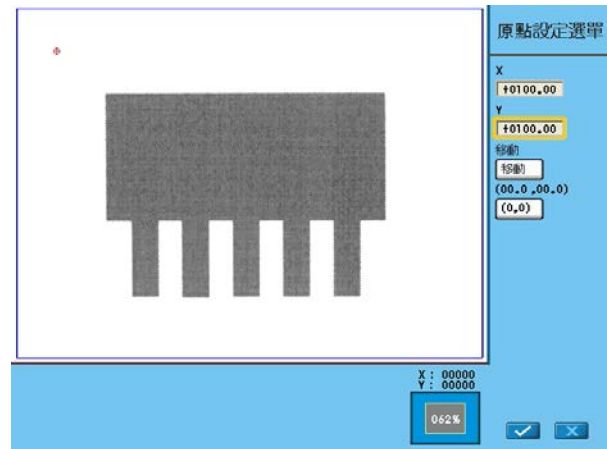

Set up origin:

Select [Edit] to open the Origin Menu.

Item 5: [Limit]

Set the range for OK/NG detection. The result is OK if within the limit and NG otherwise.

Factory defaults to maximum range and thus the result is 1 (OK).

This logic flag OK=1 and NG=0 can be passed onto the subsequent [Judge] program.

Reference Refer to Chapter 7 for a detailed description of [Judge].



Item 6: [Coordinate]

Specify whether the function adjusts the coordinates (X/Y) and angle (Theta) to match the [Inspection Window] result in the [ROI] window. Inspection windows that can be used for reference include match pattern, pattern comparison, position, and edge angle.

The [ROI] and [Mask 1]-[Mask 4] can be configured for the detection window.

After selecting [Capture], the XY coordinates of the edge position can be used as reference for subsequent programs.

When Center Display is open, it will indicate the coordinates or angle of the current center in the screen and the difference with the registered image. The RGB below can be used to modify the color of markings.

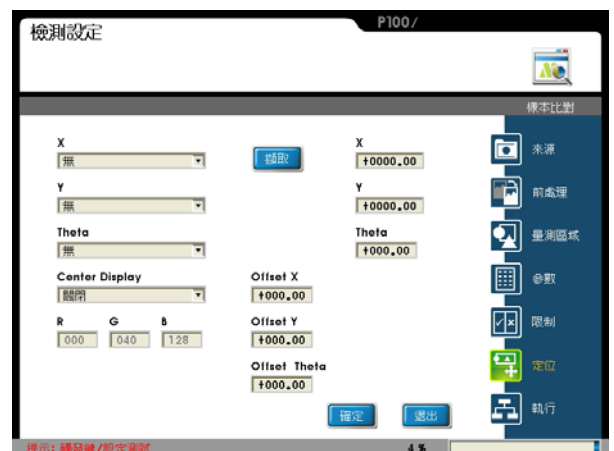

Item 7: [Execute]

Execute or disable the [Inspection Window] function.

[Always Execute]: Always execute the current [Inspection Window] while running.

[Never Execute]: The current [Inspection Window] will never be executed while running. This is useful during initial testing.

[Reference Execute]: Set the [Reference Window Item] and [Execute Condition] for flow control. Execution of [Inspection Window] is determined by the conditions above.

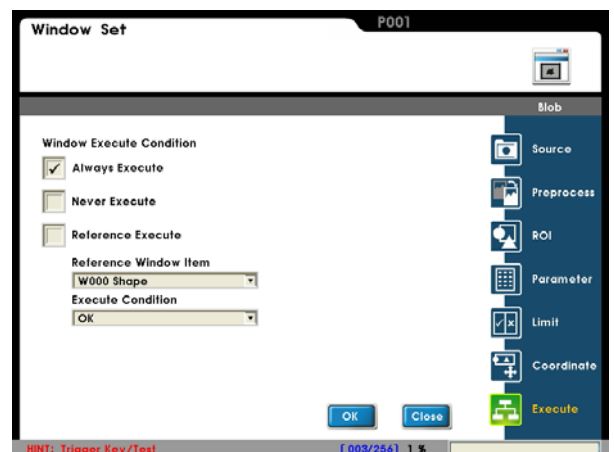

6.9 Shape

6.9.1 What is [Shape]?

The Shape function uses a reference image scanned from a designated area to search for the specified shape and outputs the XY coordinates and θ angle of the located pattern. Shape is recommended for objects tested in offset positions. The system can then pass the X, Y, and θ parameters to subsequent programs for offset calibration.

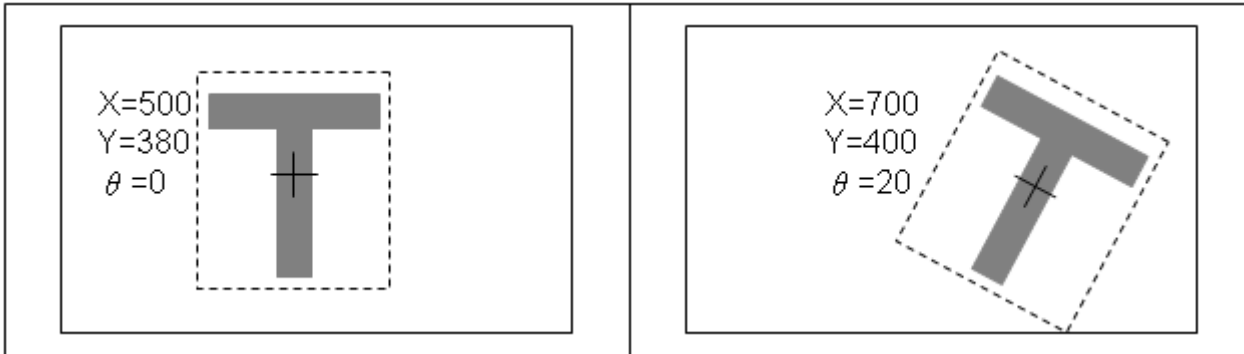

6.9.2 Detection Result

Shape output report

■ "Value" Output

- Found: 0–999
- Similarity: 0–100.00
- θ (rotation) angle: 0–359.99
- For a 0.30 megapixel camera: (1024 * 768)
X (horizontal) coordinates: 0–639.99
Y (vertical) coordinates: 0–479.99
- For a 0.80 megapixel camera: (1024 * 768)
X (horizontal) coordinates: 0–1023.99
Y (vertical) coordinates: 0–767.99

■ "Logic output (OK/NG)"

- Detection result:
A successful detection is OK = 1; otherwise the result is NG = 0.
- Found: When used with [Limit], the detection result is OK = 1 if in the limit; otherwise it is NG = 0.
- Similarity: When used with [Limit], the detection result is OK = 1 if in the limit; otherwise it is NG = 0.
- θ (rotation) angle: When used with [Limit], the detection result is OK = 1 if in the limit; otherwise it

is NG = 0.

- X (horizontal) coordinates: When used with [Limit], the detection result is OK = 1 if in the limit; otherwise it is NG = 0.
- Y (vertical) coordinates: When used with [Limit], the detection result is OK = 1 if in the limit; otherwise it is NG = 0.

6.9.3 Example application of [Shape]

The following pictures show measuring the offset X/Y/ θ of the object that the system passes to subsequent [Count] as a reference.

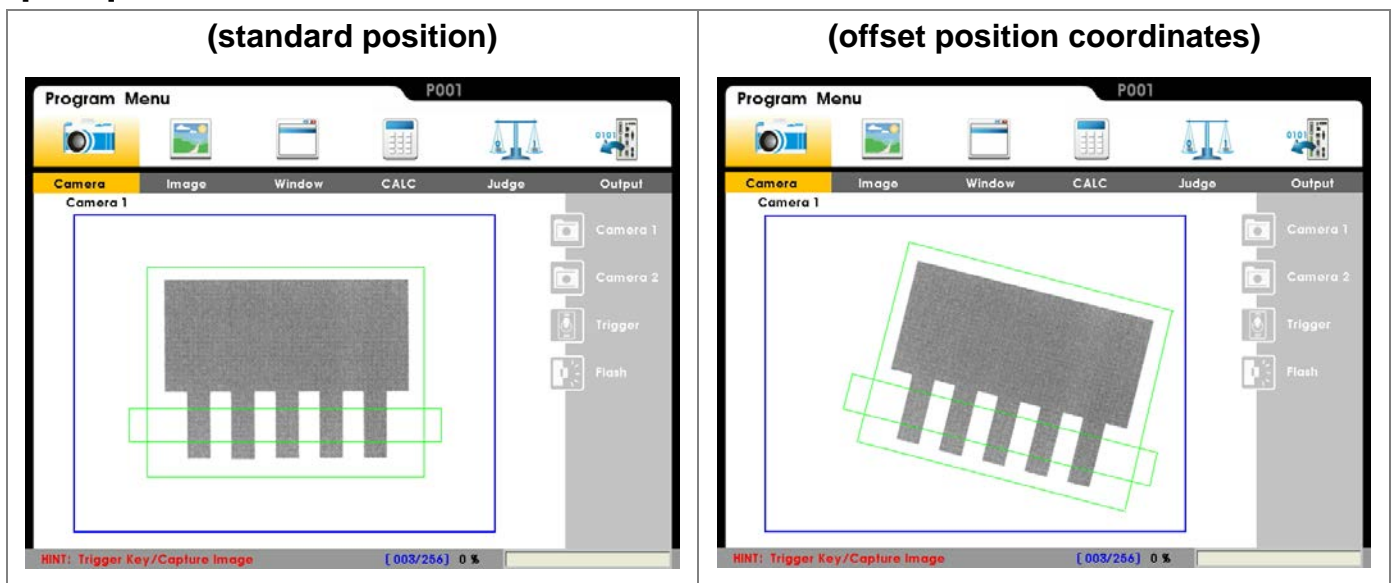

■ Detection method

The function applies both the Shape (full rectangle) and count (flat rectangle) detection functions to the standard image. At the same, the function references the position of the edge counter to the Shape parameters. For more reliable results, the counter detection frame offset matches the position offset of the test item.

6.9.4 Set up [Shape] Detection Settings

■ From [Select Function], select [Shape].

Select [Edit] or [New].

Set up the following items in this sequence: [Source], [Preprocess], [ROI], [Parameter], [Limit], [Coordinate], and [Execute].

● Item 1: [Source]

Select camera:

The system supports up to two cameras simultaneously. Select Camera 1 or Camera 2 for this detection.

Select image:

Select a pre-captured image as the reference sample for this detection.

■ Item 2: [Preprocess]

Use a software filter to first enhance the image to better meet the requirements. An appropriate preprocess filter can improve accuracy and reliability of the inspection.

The system includes more than a dozen preprocess filters, including binarization, dilation, and erosion.

You can apply up to six preprocess filters (numbered 1–6) in order.

 **Reference** For more information about preprocess, refer to Chapter 10.

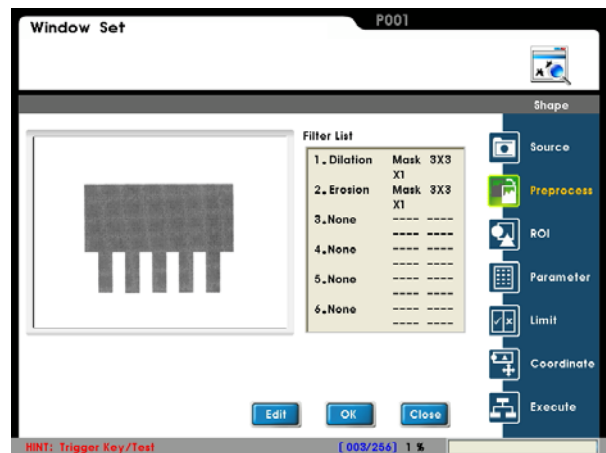
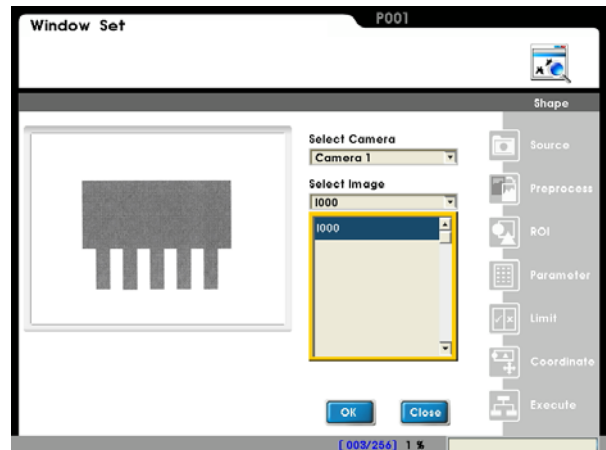
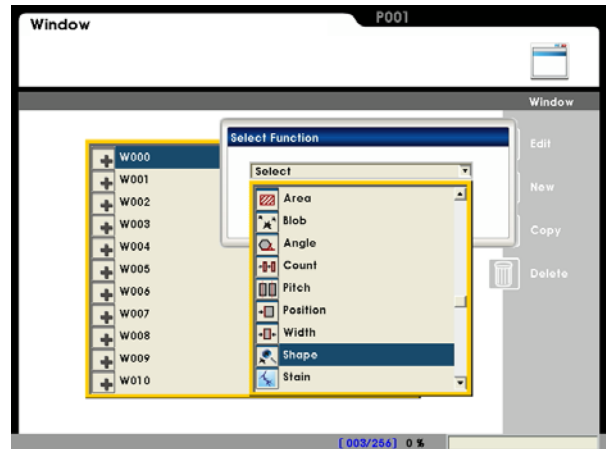

■ **Item 3: [ROI]**

ROI

Set the ROI for edge detection.

You can draw different measurement window shapes, including rectangles, ellipses, polygons, and circles.

Reference Refer to Section 3.2 [Draw ROI (Region Of Interest)].

Mask 1–Mask 4

The mask is the area to exclude from measurement. You can set a mask in the [ROI] to exclude an area from detection.

In the example to the right, the top left red rectangle is a mask.

Each [Window] program supports up to four masks.

You can draw different mask shapes, such as rectangles, ellipses, polygons, and circles.

■ **Item 4: [Parameter]**

Edge filter

Set the direction for detection search and edge filter parameters.

Examine the waveform to find the optimal parameter settings.

Origin

Define the position of the origin.

Add Pattern:

Shape is based on the bright/dark transitional edges, so the reference pattern should contain more of these edges to improve the matching reliability.

Select [Close] to finish setup.

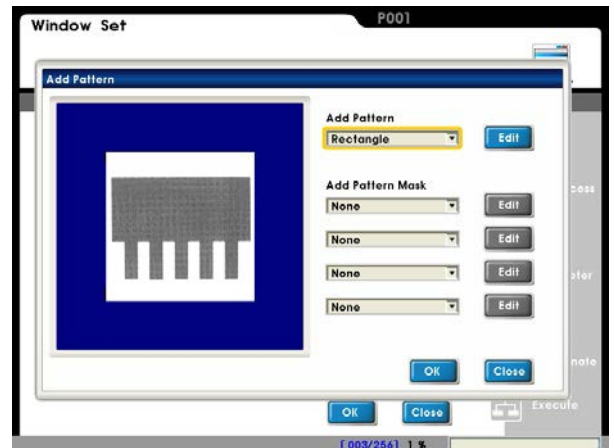
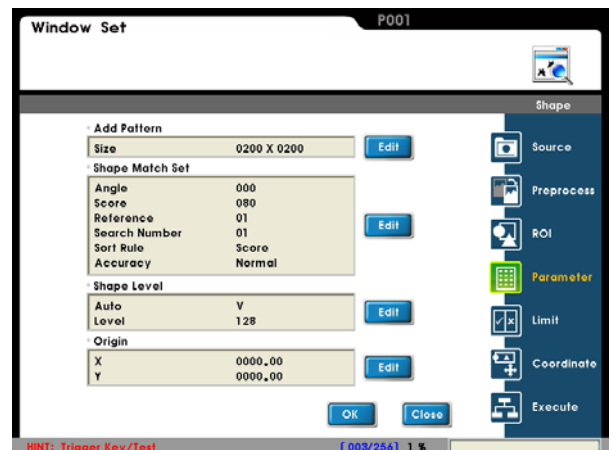
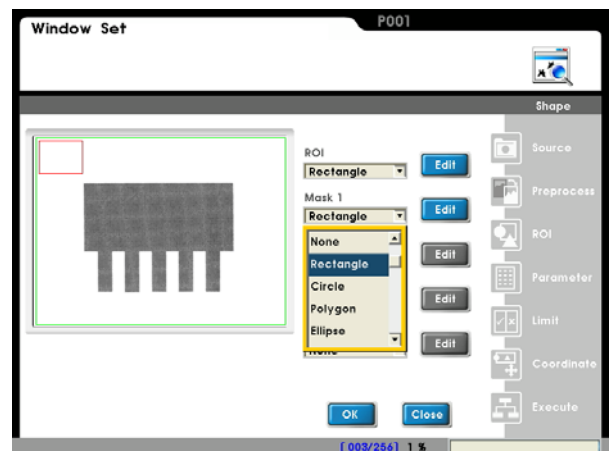
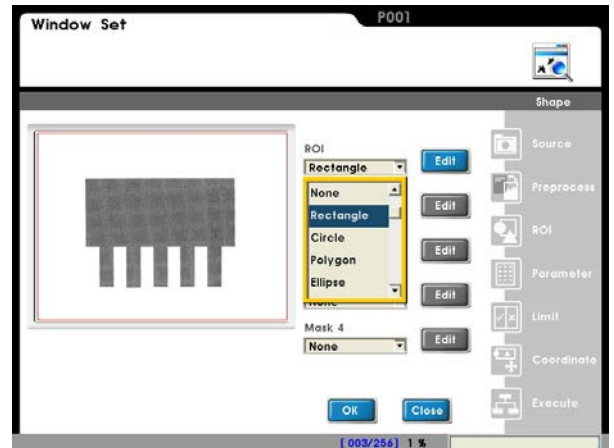

Chapter 6: Inspection Setting

Angle: Set positive and negative angle range (a value of 20 indicates -20–20).

Score: Pattern matching and coordinates are successful if higher than this score.

Reference: Output the nth result when scanning multiple targets (must use with the [Sort Rule] below).

Search Number: Adjust this quantity when scanning multiple targets; however, it increases the scan time if the target is less than the scan quantity.

Sort Rule: Set the sort method for multiple scanned targets. The nth result from [Reference] also changes.

Accuracy: Higher accuracy results in more accurate X/Y/θ parameters, but the detection time also increases.

Set up origin:

Select [Edit] to open the Origin Menu.

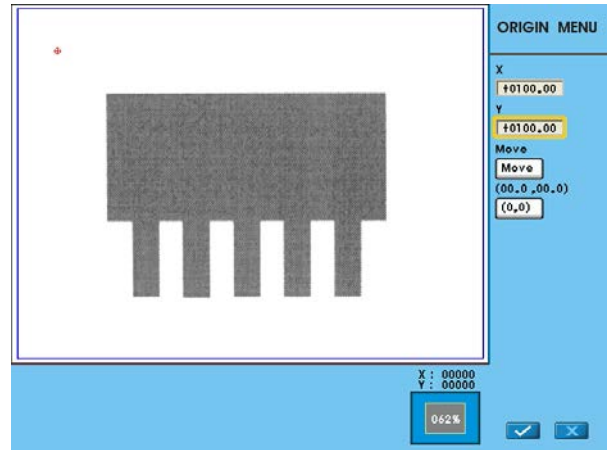

Item 5: [Limit]

Set the range for OK/NG detection. The result is OK if in the limit and NG otherwise.

The factory default setting is the maximum range and so the result is 1 (OK).

The system can pass this logic output result of OK = 1 and NG = 0 to the subsequent [Judge] program.

Reference Refer to Chapter 7 for a detailed description of [Judge].



■ Item 6: [Coordinate]

Specify whether the function adjusts the coordinates (X/Y) and angle (Theta) to match the [Window] result in the [ROI] window. As shown to the right, the [Shape] detection results automatically adjust the window X/Y/θ parameters. You can configure the [ROI] and [Mask 1]–[Mask 4] for the detection window.

Select [Capture] and the system can use the X/Y edge position coordinates as a reference for subsequent programs.

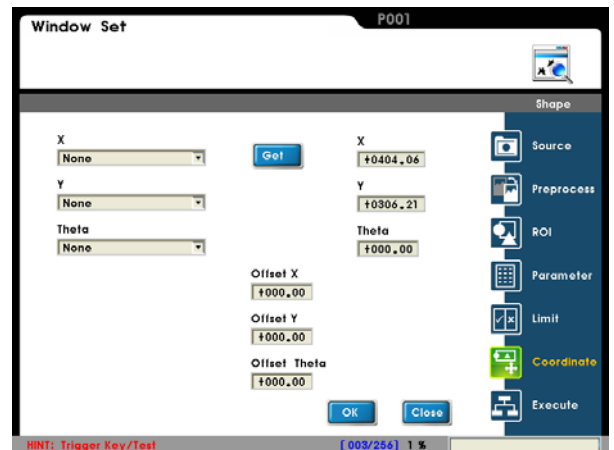

■ Item 7: [Execute]

Execute or disable the [Window] function.

[Always Execute]: Always execute the current [Window] while running.

[Never Execute]: Never execute the current [Window] while running. This is useful during initial testing.

[Reference Execute]: Set the [Reference Window Item] and [Execute Condition] for flow control. Execution of [Window] is determined by the OK/NG results of the prior inspections.



6.10 Blob

6.10.1 What is [Blob]?

The Blob function calculates the black/white pixel clusters. It detects a spot if the cluster satisfies the preset criteria.

The following picture shows spot detection configured for black clusters in sizes of 4–10 pixels. Blob finds three spots (5, 6, 9-pixel clusters) and excludes the two 24-pixel clusters.

Blob sorts the spots in order of pixel size.

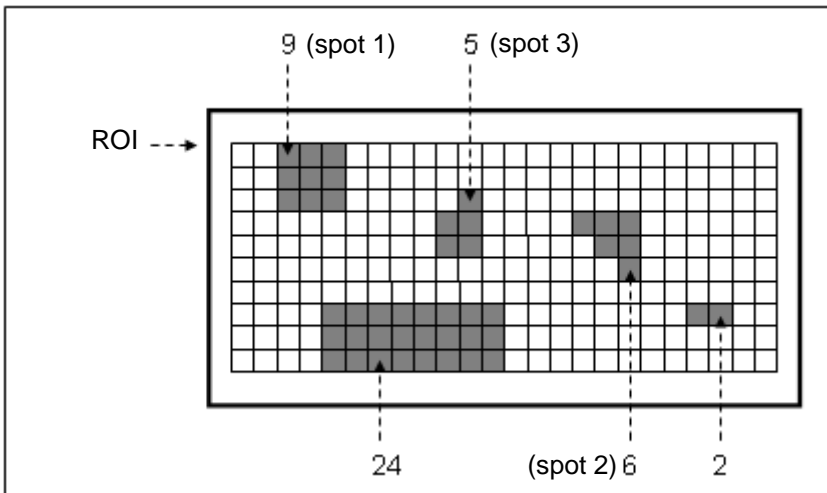

6.10.2 Detection Result

Blob detection output report

■ "Value" Output

- Spots found: Range: 0–999
- Sort by horizontal and vertical coordinates
For a 0.30 megapixel camera: (640 * 480); For a 0.80 megapixel camera: (1024 * 768)
X (horizontal) coordinates: 0–639 X (horizontal) coordinates: 0–1023
Y (vertical) coordinates: 0–479 Y (vertical) coordinates: 0–767
- Sort by area: Range 0–999999
- Sort by circumference: Range 0–999999

■ "Logic output (OK/NG)"

- Spot number, horizontal position, vertical position, area, and circumference.
When used with [Limit] for the above measurements, the detection result is OK = 1 if the limit is satisfied; otherwise it is NG = 0.

6.10.3 Example application of [Blob]

The following picture shows measuring the center of the gear.

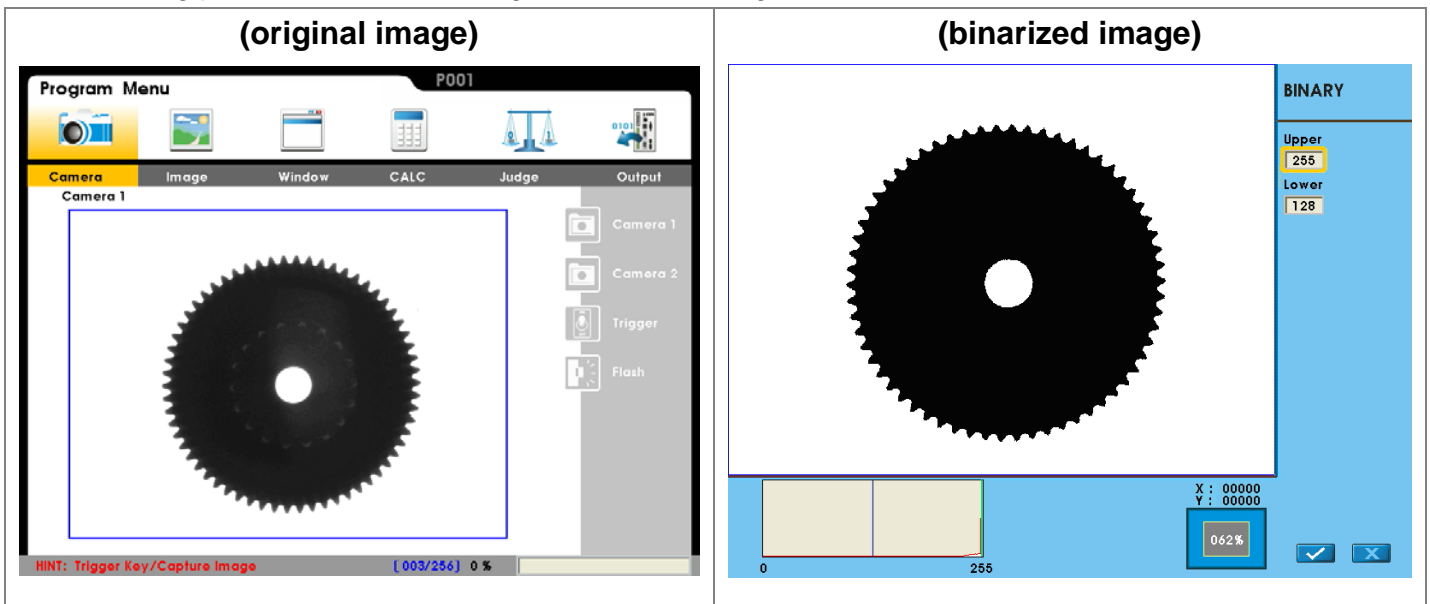

■ Detection method

Before Blob detection, the function binarizes the original grayscale image into black/white pixels, and then applies Blob detection on black pixel cluster to obtain the XY coordinates of the center.

6.10.4 Set up [Blob] Detection Settings

■ From [Select Function], select [Blob].

Select [Edit] or [New].

Set up the following items in this sequence: [Source], [Preprocess], [ROI], [Parameter], [Limit], [Coordinate], and [Execute].

● Item 1: [Source]

Select camera

The system supports up to two cameras simultaneously. Select Camera 1 or Camera 2 for this detection.

Select image

Select a pre-captured image as the reference sample for this detection.

■ Item 2: [Preprocess]

Use a software filter to first enhance the image to better meet the requirements. An appropriate preprocess filter can improve inspection accuracy and reliability.

The system includes more than a dozen preprocess filters, including binarization, dilation, and erosion.

You can apply up to six preprocess filters (numbered 1–6) in order.

 **Reference** For more information about preprocess, refer to Chapter 10.

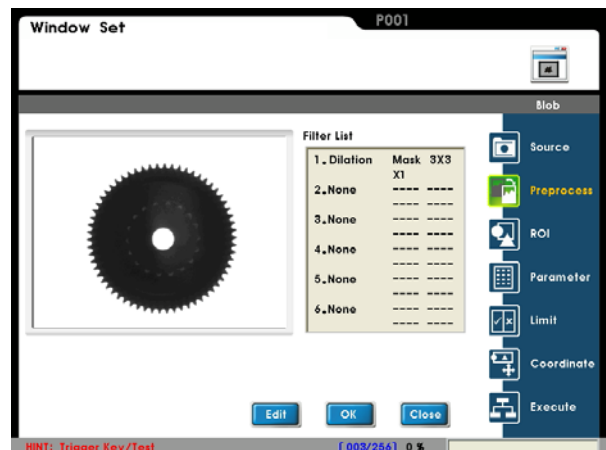
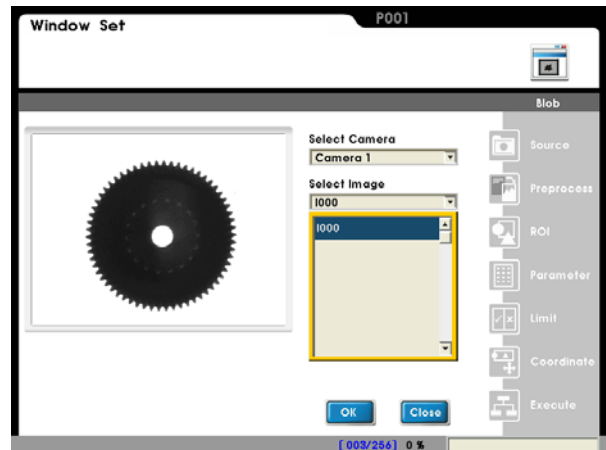
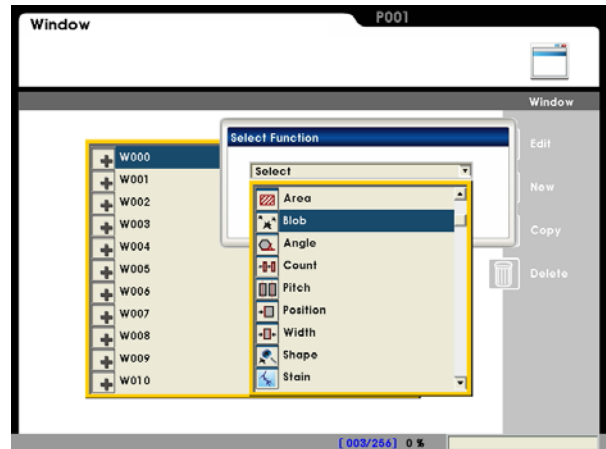

■ **Item 3: [ROI]**

ROI

A smaller ROI requires less detection time.

You can draw different measurement window shapes, including rectangles, ellipses, polygons, and circles.

 **Reference** Refer to Section 3.2 [Draw ROI (Region Of Interest)].

Mask 1–Mask 4

The mask is the area to exclude from measurement. You can set a mask in the [ROI] to exclude an area from detection.

Each [Window] program supports up to four masks.

You can draw different mask shapes, such as rectangles, ellipses, polygons, and circles.

■ **Item 4: [Parameter]**

Binarization: The grayscale image is binarized into black and white pixels for area inspection.

Detect Object: Count the black pixels or white pixels.

Origin: Define the position of the origin.

Blob Condition: Set the upper/lower limit for number of black pixel cluster.

Reference: If multiple spots are found (sorted by descending pixel size), set the nth result to show as the reference [Limit].

Set up binarization

Select [Edit] and adjust the upper/lower limits. The resulting image is changes dynamically.

White pixels indicate the grayscale image inside the ROI, and black pixels are outside the area.

The grayscale level histogram shown in the lower left of the screen.

 **Reference** For more information about binarization, refer to Chapter 11.

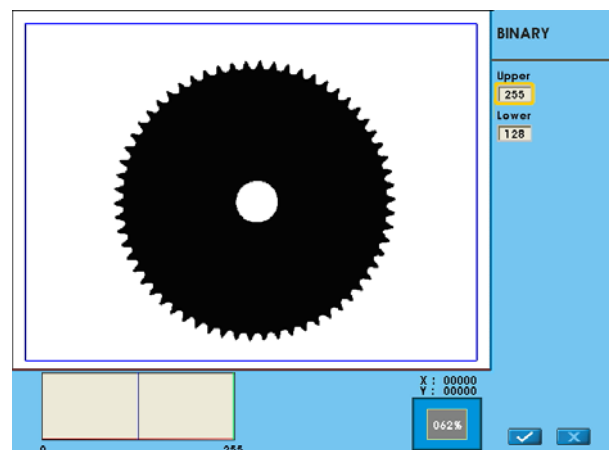
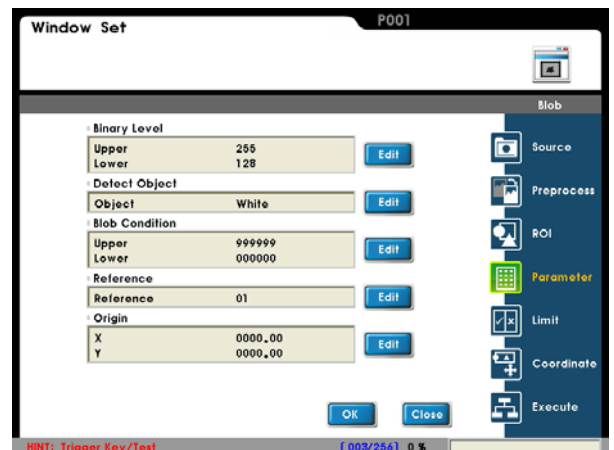
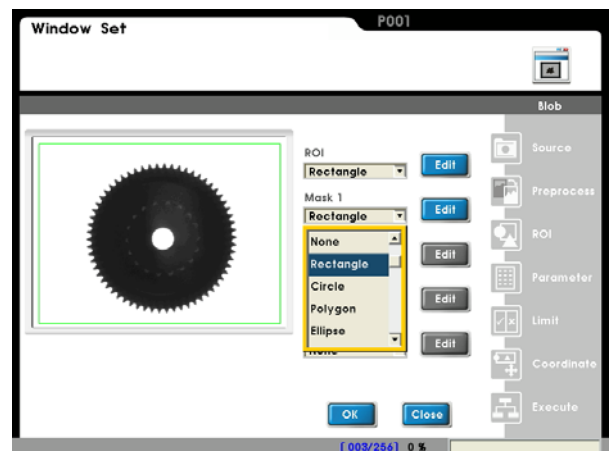
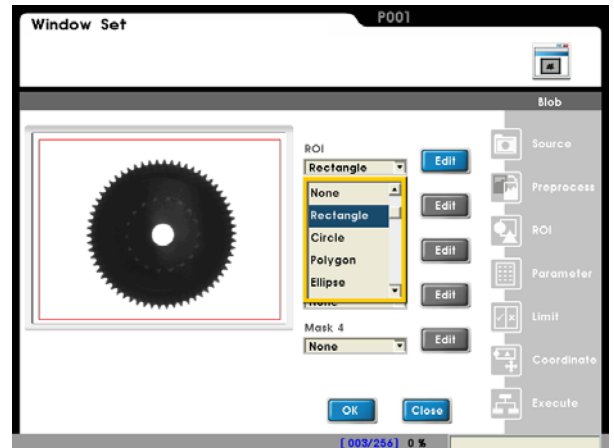

Set up origin

Select [Edit] to open the Origin Menu.

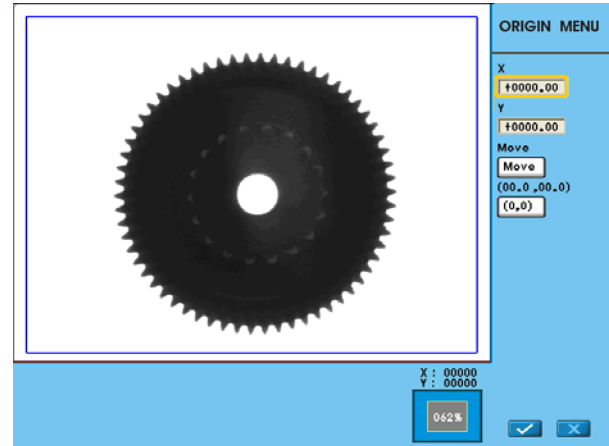

Item 5: [Limit]

Set the range for OK/NG detection. The result is OK if in the limit and NG otherwise.

The factory default setting is the maximum range and so the result is 1 (OK).

The system can pass this logic output result of OK = 1 and NG = 0 to the subsequent [Judge] program.

Reference Refer to Chapter 7 for a detailed description of [Judge].

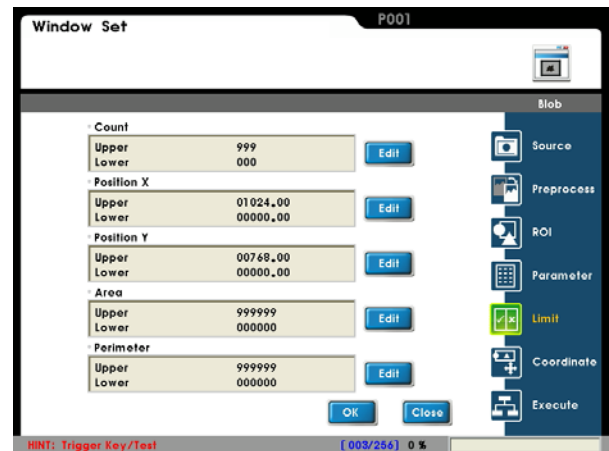

Item 6: [Coordinate]

Specify whether the function adjusts the coordinates (X/Y) and angle (Theta) to match the [Window] result in the [ROI] window. As shown to the right, the [Shape] detection results automatically adjust the window X/Y/θ parameters. You can configure the [ROI] and [Mask 1]–[Mask 4] for the detection window.

Reference For more information on coordinates, refer to Section 6.9.

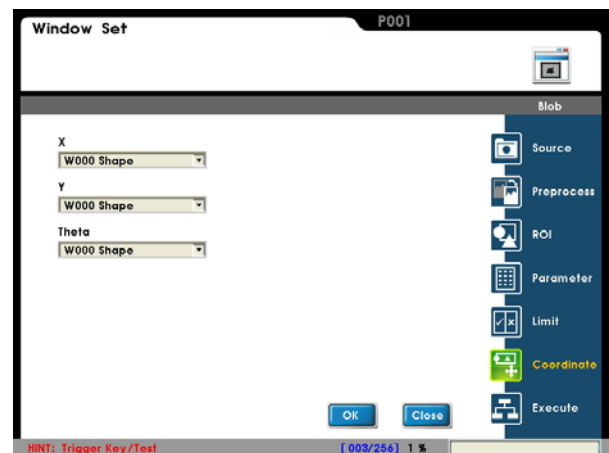

Item 7: [Execute]

Execute or disable the [Window] function.

[Always Execute]: Always execute the current [Window] while running.

[Never Execute]: Never execute the current [Window] while running. This is useful during initial testing.

[Reference Execute]: Set the [Reference Window Item] and [Execute Condition] for flow control. Execution of [Window] is determined by the OK/NG results of the prior inspections.



6.11 Intensity

6.11.1 What is [Intensity]?

Intensity is the maximum brightness, minimum brightness, average brightness, and standard deviation of all grayscale pixels in the ROI.

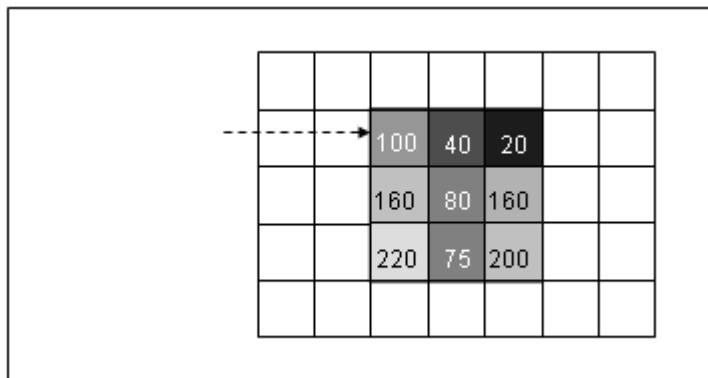

Maximum brightness = 220

Minimum brightness = 20

Average brightness =

$(100 + 40 + 20 + 160 + 80 + 160 + 220 + 75 + 200) / 9 = 117.22$

Standard deviation = 65.73

6.11.2 Detection Result

Intensity output report

■ "Value" Output

- Maximum brightness: range 0.00–255.00
- Minimum brightness: range 0.00–255.00
- Average brightness: range 0.00–255.00
- Brightness deviation: range 0.00–255.00

■ "Logic output (OK/NG)"

- Maximum brightness, minimum brightness, average brightness, and brightness deviation.
When used with [Limit] for the above measurements, the detection result is OK = 1 if the limit is satisfied; otherwise it is NG = 0.

6.11.3 Example application of [Intensity]

The following picture shows measuring the LED for brightness and uniformity.

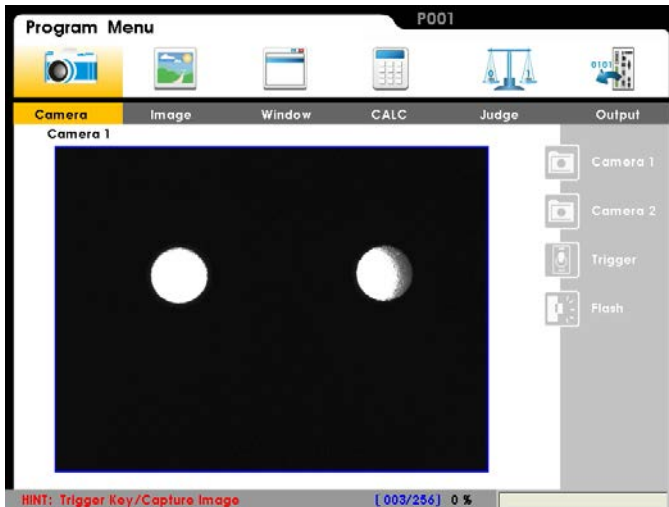

■ Detection method

This method uses two image intensity filters to measure the brightness and uniformity of the two LEDs side-by-side.

The LED on the left has uniform brightness, so "Average brightness = 200". "Standard brightness deviation = 10".

The LED on the right shows a shadow, so "Average brightness = 150". "Standard brightness deviation = 40".

Use the average and standard deviation to check the LED uniformity quality.

6.11.4 Set up [Intensity] Detection Settings

■ From [Select Function], select [Intensity].

Select [Edit] or [New].

Set up the following items in this sequence: [Source], [Preprocess], [ROI], [Parameter], [Limit], [Coordinate], and [Execute].

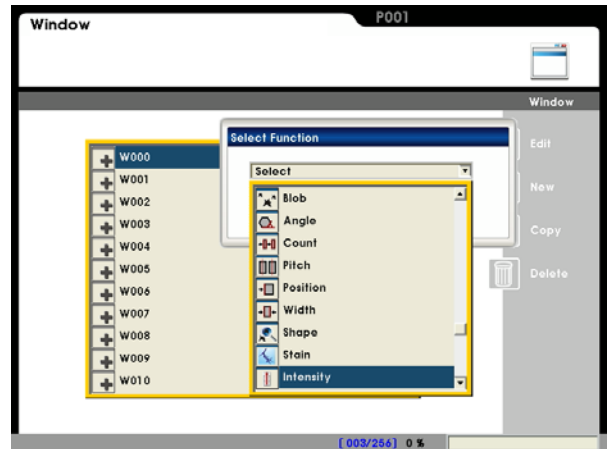

● Item 1: [Source]

Select camera:

The system supports up to two cameras simultaneously. Select Camera 1 or Camera 2 for this detection.

Select image

Select a pre-captured image as the reference sample for this detection.

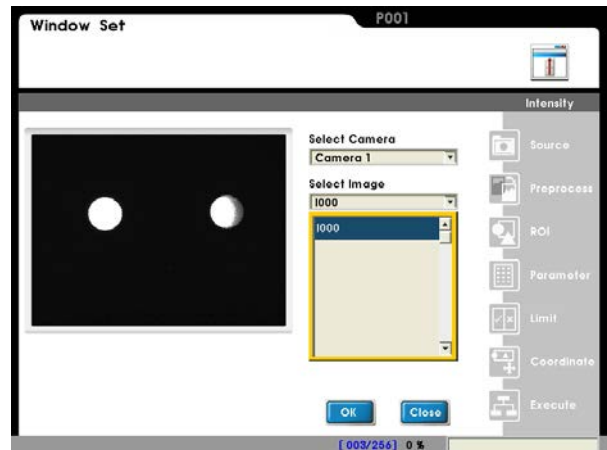

■ Item 2: [Preprocess]

Use a software filter to first enhance the image to better meet the requirements. An appropriate preprocess filter can improve inspection accuracy and reliability.

The system includes more than a dozen preprocess filters, including binarization, dilation, and erosion.

You can apply up to six preprocess filters (numbered 1–6) in order.

Reference For more information about preprocess, refer to Chapter 11.

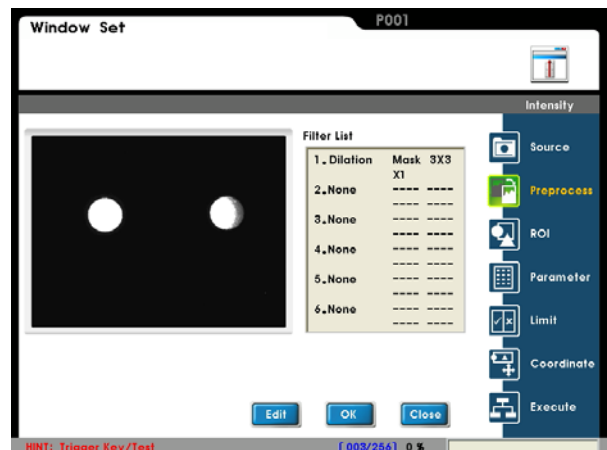

■ Item 3: [ROI]

ROI

A smaller ROI requires less detection time.

You can draw different measurement window shapes, including rectangles, ellipses, polygons, and circles.

 **Reference** Refer to Section 3.2 [Draw ROI (Region Of Interest)].

Mask 1–Mask 4

The mask is the area to exclude from measurement. You can set a mask in the [ROI] to exclude an area from detection.

Each [Window] program supports up to four masks.

You can draw different mask shapes, such as rectangles, ellipses, polygons, and circles.

■ Item 4: [Parameter]

Process

Specify a detection result of [Average] or [Standard deviation].

Average: Average grayscale level of all pixels.

Standard deviation: Standard deviation from the average.

A large standard deviation indicates that most pixels differ a lot from the average. Conversely, a smaller standard deviation indicates that most pixels are near the average.

Origin

Define the position of the origin.

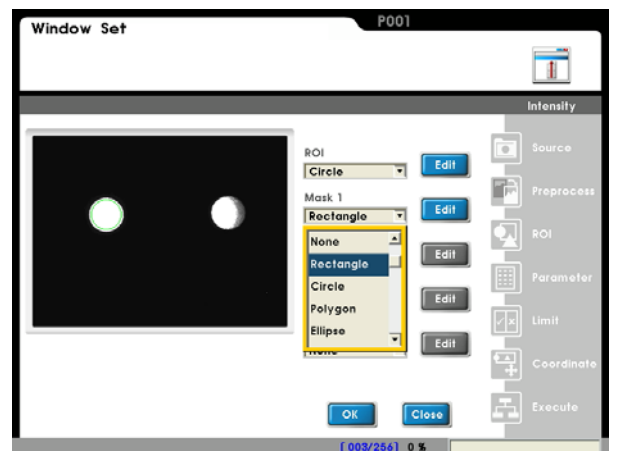
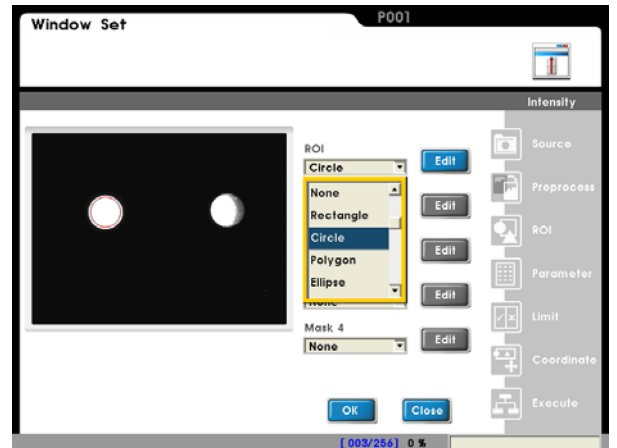

Set up origin:

Select [Edit] to open the Origin Menu.



Item 5: [Limit]

Set the range for OK/NG detection. The result is OK if in the limit and NG otherwise.

The factory default setting is the maximum range and so the result is 1 (OK).

The system can pass this logic output result of OK = 1 and NG = 0 to the subsequent [Judge] program.

Reference Refer to Chapter 7 for a detailed description of [Judge].

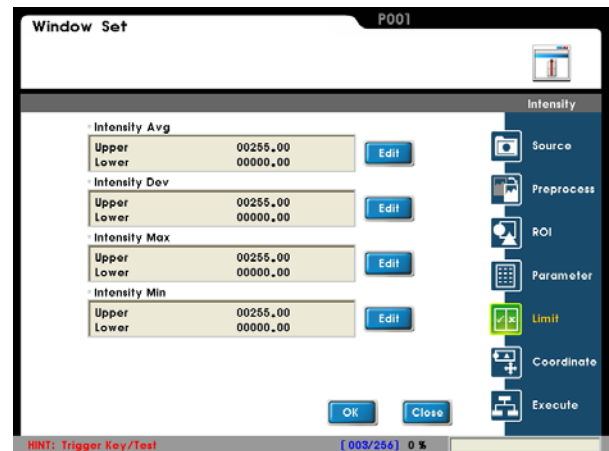

Item 6: [Coordinate]

Specify whether the function adjusts the coordinates (X/Y) and angle (Theta) to match the [Window] result in the [ROI] window. As shown to the right, the [Shape] detection results automatically adjust the window X/Y/θ parameters. You can configure the [ROI] and [Mask 1]–[Mask 4] for the detection window.

Reference For more information on coordinates, refer to Section 6.9.



Item 7: [Execute]

Execute or disable the [Window] function.

[Always Execute]: Always execute the current [Window] while running.

[Never Execute]: Never execute the current [Window] while running. This is useful during initial testing.

[Reference Execute]: Set the [Reference Window Item] and [Execute Condition] for flow control. Execution of [Window] is determined by the OK/NG results of the prior inspections.



6.12 Position Trace

6.12.1 What is [Position Trace]?

The Position Trace function detects the XY coordinates where the grayscale level exceeds the threshold. The results are the maximum and minimum edge coordinates.

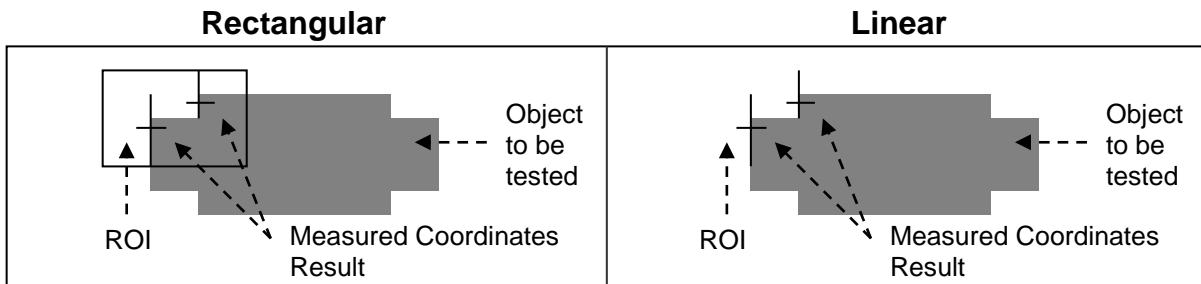

6.12.2 Detection Result

Position Trace output report

■ "Value" Output

- For a 0.30 megapixel camera: (640 * 480)
X (horizontal) coordinates: 0–639
Y (vertical) coordinates: 0–479
- For a 0.80 megapixel camera: (1024 * 768)
X (horizontal) coordinates: 0–1023
Y (vertical) coordinates: 0–767

■ "Logic output (OK/NG)"

- Detection result:
A successful detection is 1 = OK; otherwise the result is 0 = NG.
- Maximum and minimum X (horizontal) coordinates: When used with [Limit], the detection result is OK = 1 if in the limit; otherwise it is NG = 0.
- Maximum and minimum Y (vertical) coordinates: When used with [Limit], the detection result is OK = 1 if in the limit; otherwise it is NG = 0.

6.12.3 Example application of [Position Trace]

The following picture shows inspecting the pin lengths.

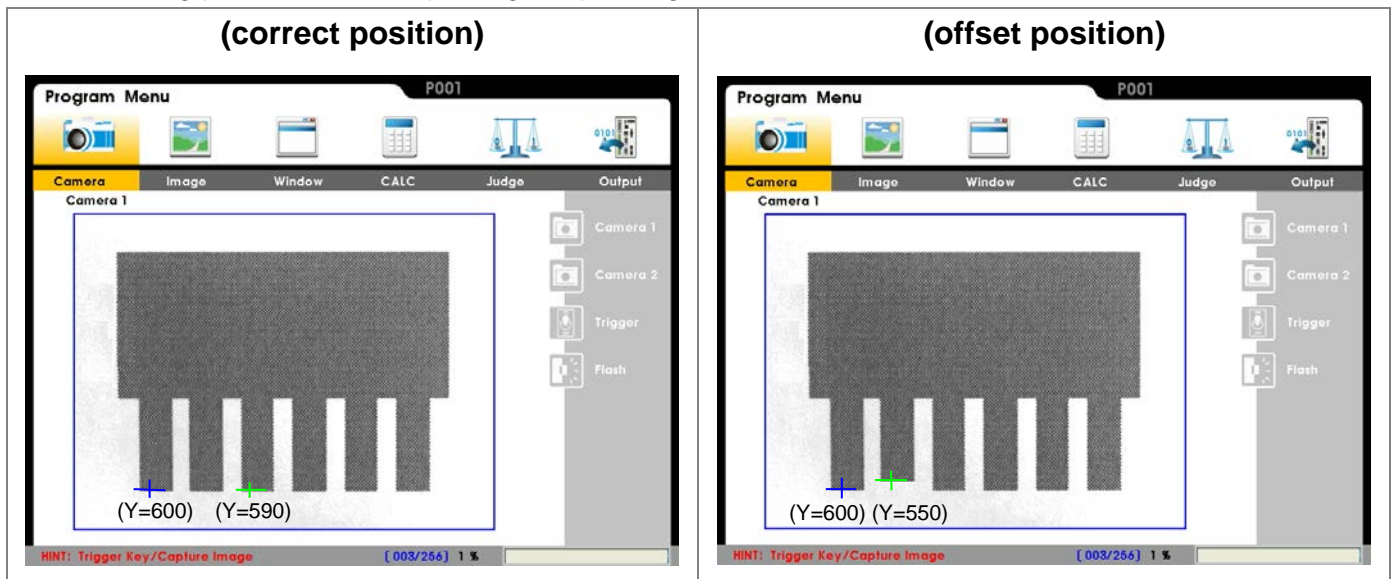

■ Detection method

For the edge position detection function, the function scans the maximum and minimum Y coordinates from bottom to top. The detection result is OK if the Y coordinates fall in the limit range; otherwise, the detection result is NG if it exceeds the limit range because the offset length is too large.

6.12.4 Set up [Position Trace] Detection Settings

■ From [Select Function], select [Position Trace].

Select [Edit] or [New].

Set up the following items in sequence: [Source], [Preprocess], [ROI], [Parameter], [Limit], and [Execute].

● Item 1: [Source]

Select camera

The system supports up to two cameras simultaneously.

Select Camera 1 or Camera 2 for this detection.

Select image

Select a pre-captured image as the reference sample for this detection.

■ Item 2: [Preprocess]

Use a software filter to first enhance the image to better meet the requirements. An appropriate preprocess filter can improve inspection accuracy and reliability.

The system includes more than a dozen preprocess filters, including binarization, dilation, and erosion.

You can apply up to six preprocess filters (numbered 1–6) in order.

 **Reference** For more information about preprocess, refer to Chapter 11.

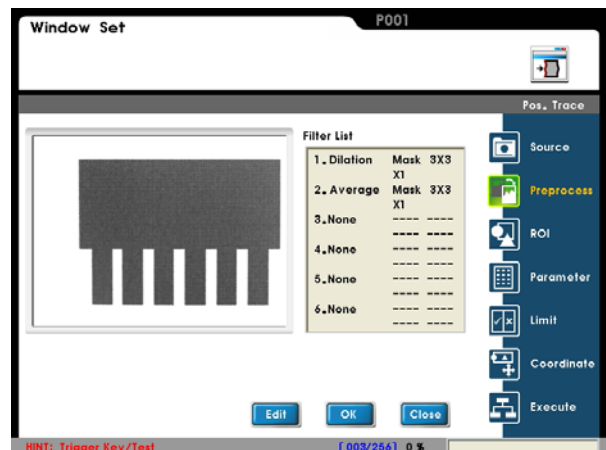
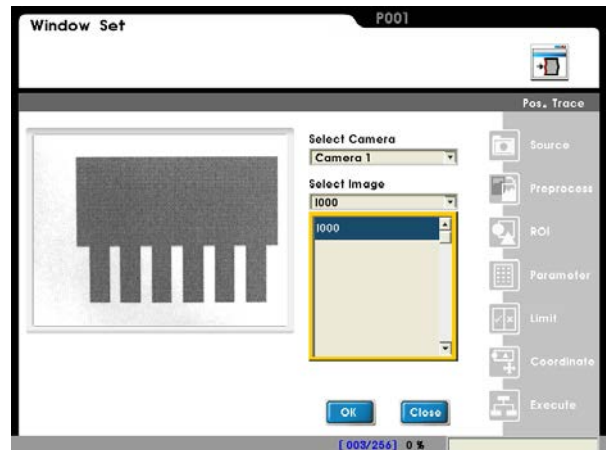
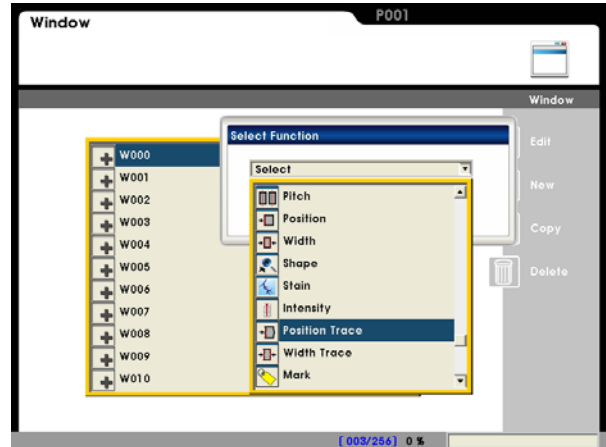

■ **Item 3: [ROI]**

ROI

Set the ROI for edge detection.

You can draw different measurement window shapes, including rectangles, ellipses, polygons, and circles.

Reference Refer to Section 3.2 [Draw ROI (Region Of Interest)].

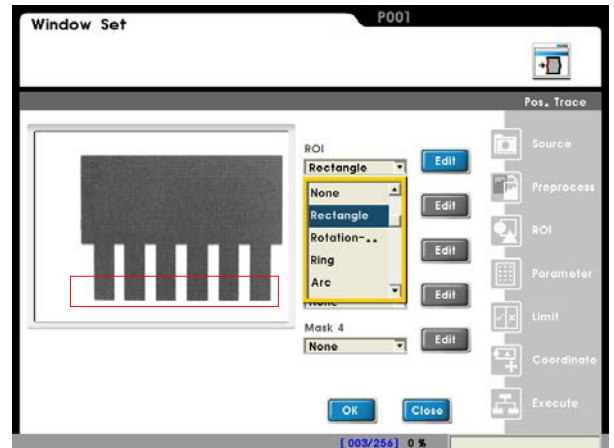

Mask 1–Mask 4

The mask is the area to exclude from measurement. You can set a mask in the [ROI] to exclude an area from detection.

In the example to the right, the red rectangle is a mask.

Each [Window] program supports up to four masks.

You can draw different mask shapes, such as rectangles, ellipses, polygons, and circles.

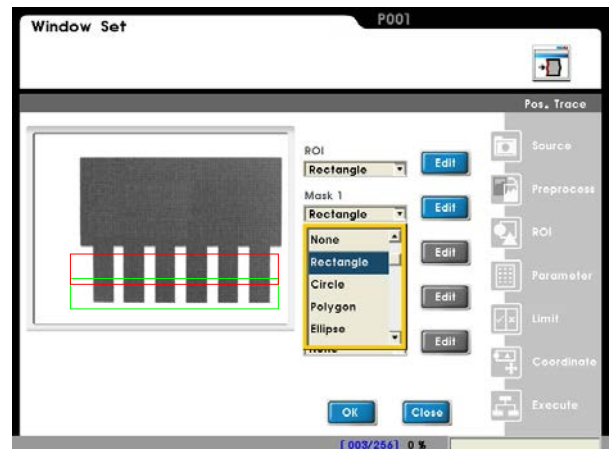

■ **Item 4: [Parameter]**

Edge filter

Set the direction for the detection search and edge filter parameters.

Examine the waveform to find the optimal parameter settings.

Circle Check

Use "Circle Function" and "Circle Modify" to enhance edge detection of circular target objects.

Origin

Define the position of the origin.

Set up origin:

Select [Edit] to open the Origin Menu.

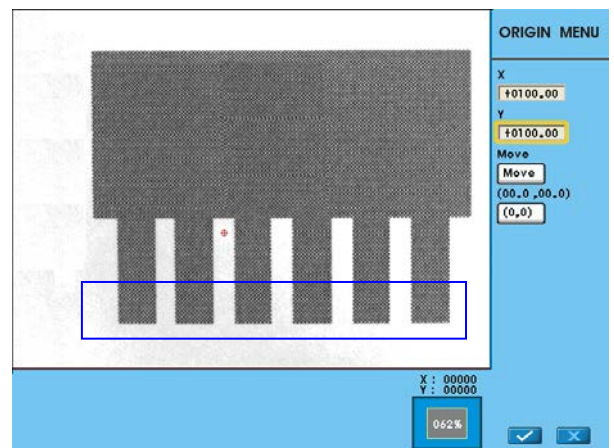
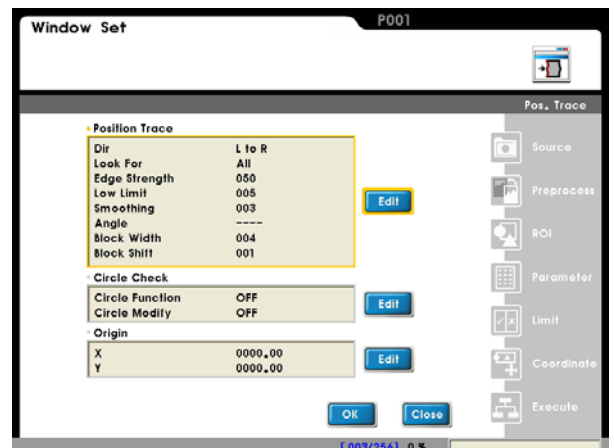

Chapter 6: Inspection Setting

Item 5: [Limit]

Set the range for OK/NG detection. The result is OK if in the limit and NG otherwise.

The factory default setting is the maximum range and so the result is 1 (OK).

The system can pass this logic output result of OK = 1 and NG = 0 to the subsequent [Judge] program.

Reference Refer to Chapter 7 for a detailed description of [Judge].



Item 6: [Execute]

Execute or disable the [Window] function.

[Always Execute]: Always execute the current [Window] while running.

[Never Execute]: Never execute the current [Window] while running. This is useful during initial testing.

[Reference Execute]: Set the [Reference Window Item] and [Execute Condition] for flow control. Execution of [Window] is determined by the OK/NG results of the prior inspections.



6.13 Width Trace

6.13.1 What is [Width Trace]?

The Width Trace function detects the distances between all edges (inner or outer). The results are the maximum and minimum distances. The result is OK if the maximum and minimum widths satisfy the limit; otherwise, the result is NG.

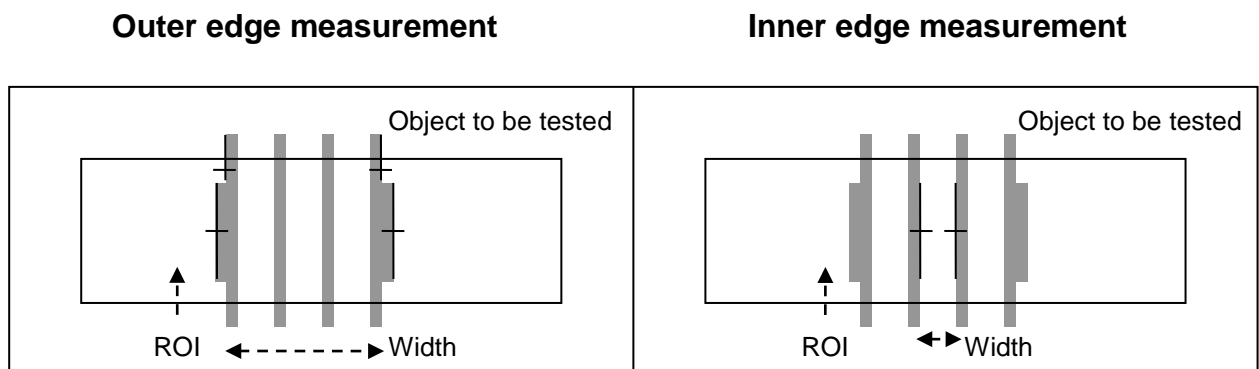

6.13.2 Detection Result

Width Trace output report

■ "Value" Output

- Width Trace Values Found: Range: 0–9999
- Positions of first and second points:
 - For a 0.30 megapixel camera: X (horizontal) coordinates: 0–639
Y (vertical) coordinates: 0–479
 - For a 0.80 megapixel camera: X (horizontal) coordinates: 0–1023
Y (vertical) coordinates: 0–767

■ "Logic output (OK/NG)"

- Width Trace: Used with the [Limit], the detection result is OK = 1 if the maximum and minimum widths satisfy the restriction; otherwise the result is NG = 0.

6.13.3 Example application of [Width Trace]

The following picture shows measuring the inner and outer widths and roundness of the O-circle.

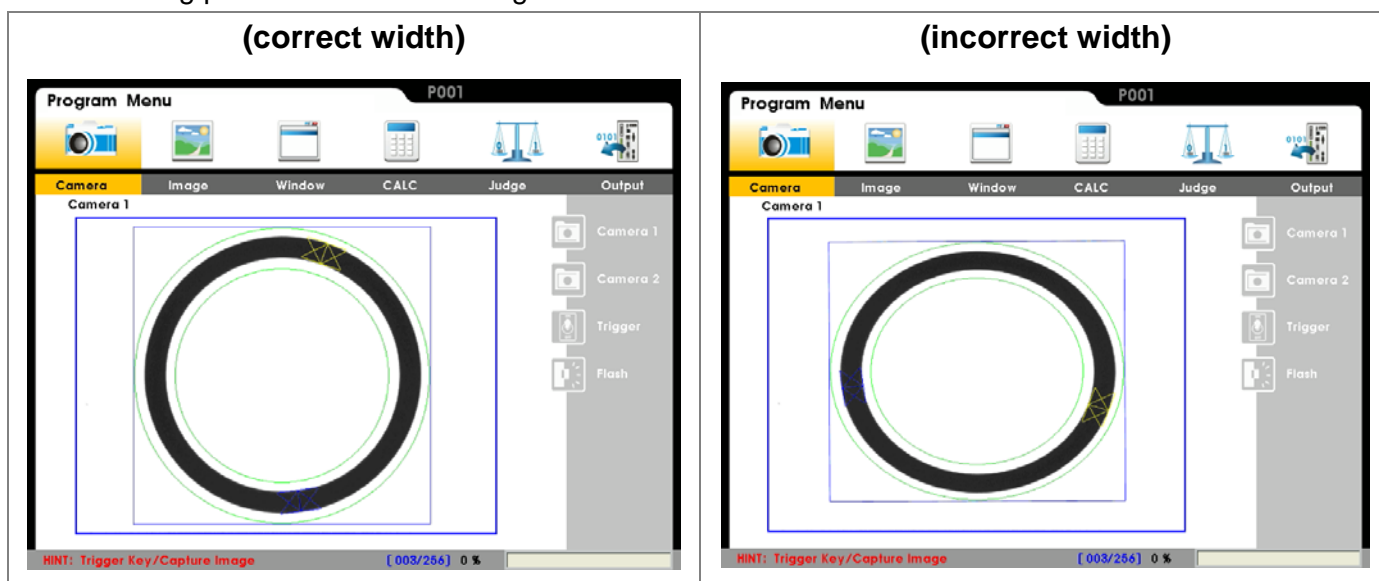

■ Detection method

The Width Trace function measures the widths of the O-circle at different locations while simultaneously detecting the roundness. The result is OK if the widths and roundness satisfy the limit; otherwise, the result is NG.

6.13.4 Set up [Width Trace] Detection Settings

- From [Select Function], select [Width Trace].

Select [Edit] or [New].

Set up the following items in sequence: [Source], [Preprocess], [ROI], [Parameter], [Limit], and [Execute].

- Item 1: [Source]

Select camera

The system supports up to two cameras simultaneously.

Select Camera 1 or Camera 2 for this detection.

Select image

Select a pre-captured image as the reference sample for this detection.

- Item 2: [Preprocess]

Use a software filter to first enhance the image to better meet the requirements. An appropriate preprocess filter can improve accuracy and reliability of the inspection.

The system includes more than a dozen preprocess filters, including binarization, dilation, and erosion.

You can apply up to six preprocess filters (numbered 1–6) in order.

 **Reference** For more information about preprocess, refer to Chapter 11.

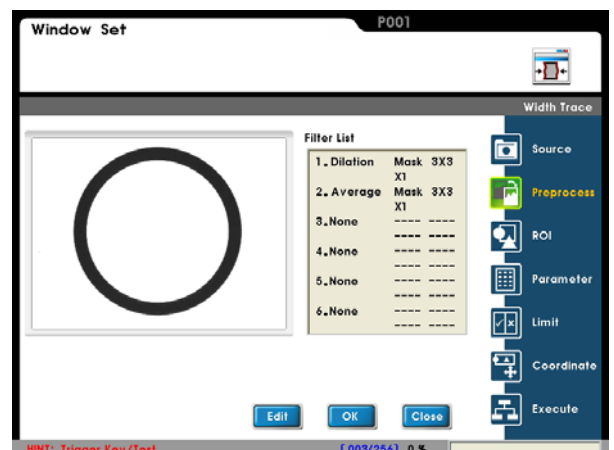
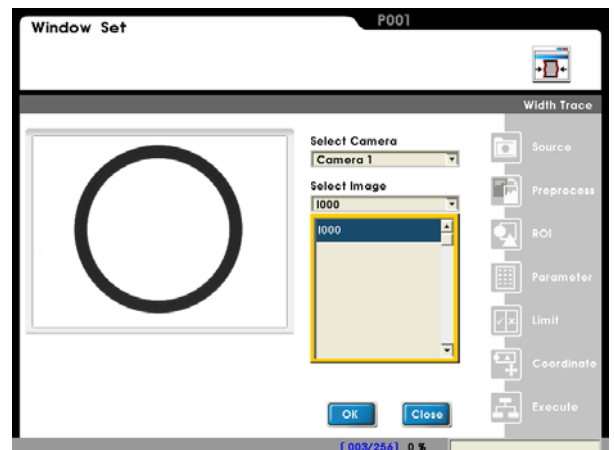
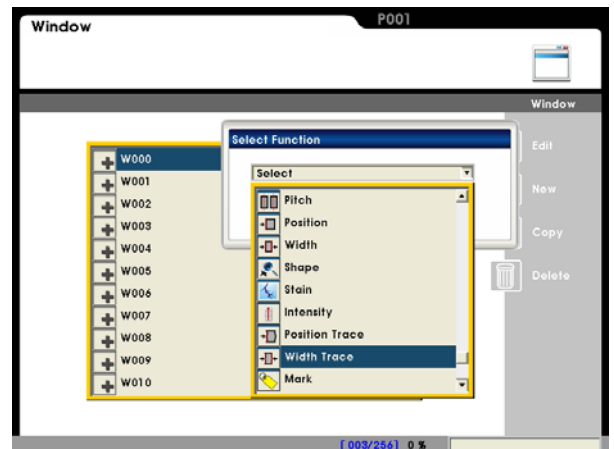

Item 3: [ROI]

ROI

Set the ROI for edge detection.

You can draw different measurement window shapes, including rectangles, ellipses, polygons, and circles.

Reference Refer to Section 3.2 [Draw ROI (Region Of Interest)].

Mask 1–Mask 4

The mask is the area to exclude from measurement. You can set a mask in the [ROI] to exclude an area from detection.

In the example to the right, the red rectangle is a mask.

Each [Window] program supports up to four masks.

You can draw different mask shapes, such as rectangles, ellipses, polygons, and circles.

Item 4: [Parameter]

Edge filter

Set the direction for the detection search and edge filter parameters.

Examine the waveform to find the optimal parameter settings.

Circle Check

Use "Circle Function" and "Circle Modify" to enhance edge detection of circular target objects.

Origin

Define the position of the origin.

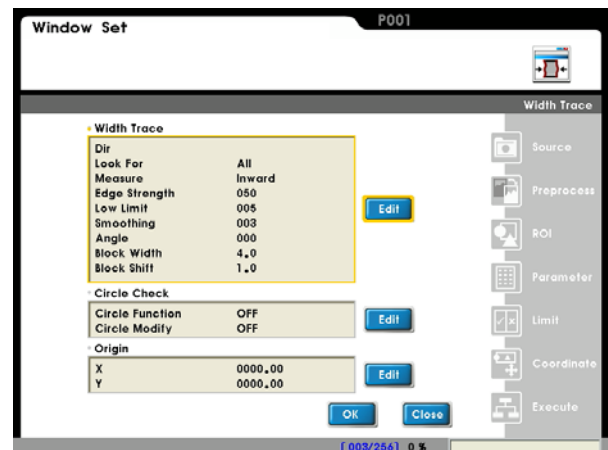
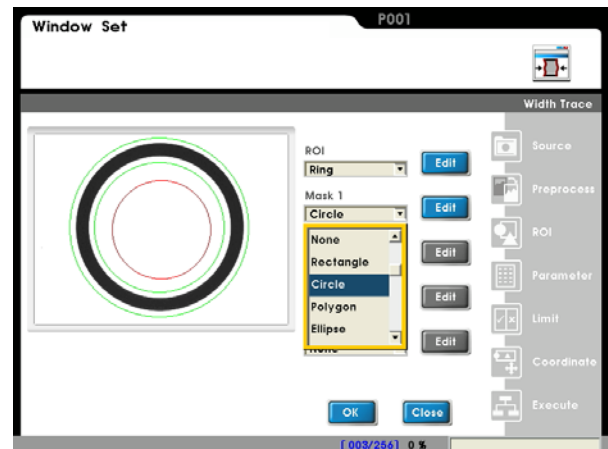
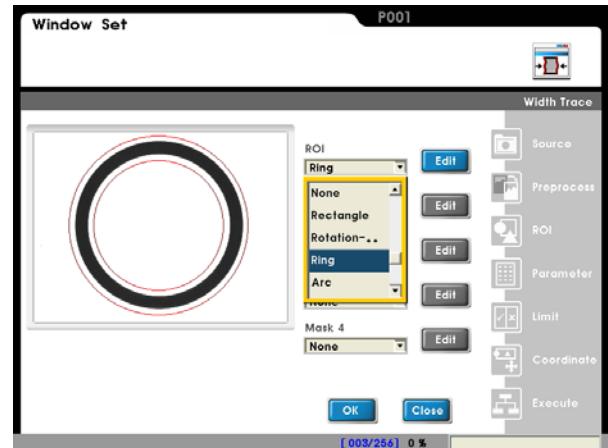

Set up origin:

Select [Edit] to open the Origin Menu.

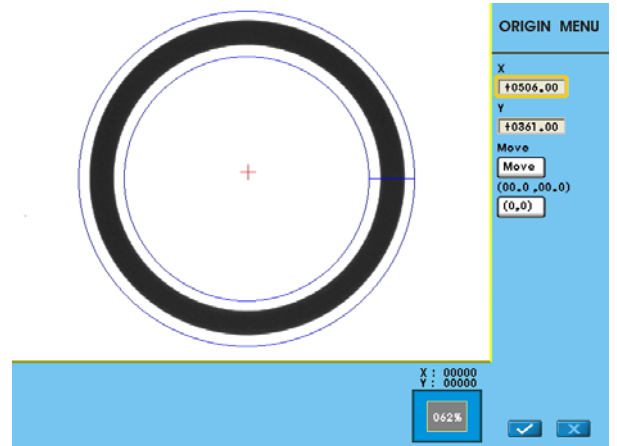

Item 5: [Limit]

Set the range for OK/NG detection. The result is OK if in the limit and NG otherwise.

The factory default setting is the maximum range and so the result is 1 (OK).

The system can pass this logic output result of OK = 1 and NG = 0 to the subsequent [Judge] program.

Reference Refer to Chapter 7 for a detailed description of [Judge].

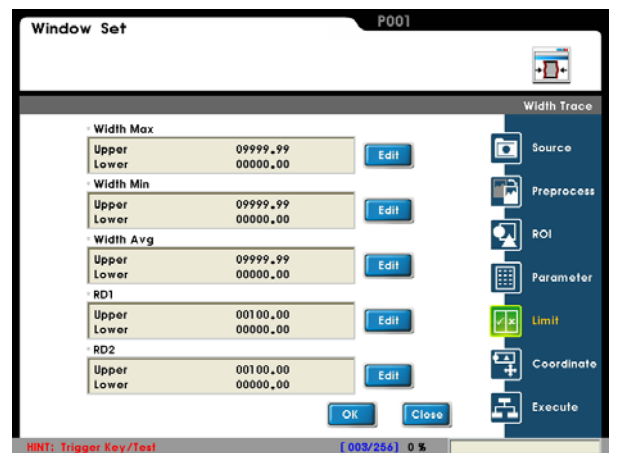

Item 6: [Execute]

Execute or disable the [Window] function.

[Always Execute]: Always execute the current [Window] while running.

[Never Execute]: Never execute the current [Window] while running. This is useful during initial testing.

[Reference Execute]: Set the [Reference Window Item] and [Execute Condition] for flow control. Execution of [Window] is determined by the OK/NG results of the prior inspections.

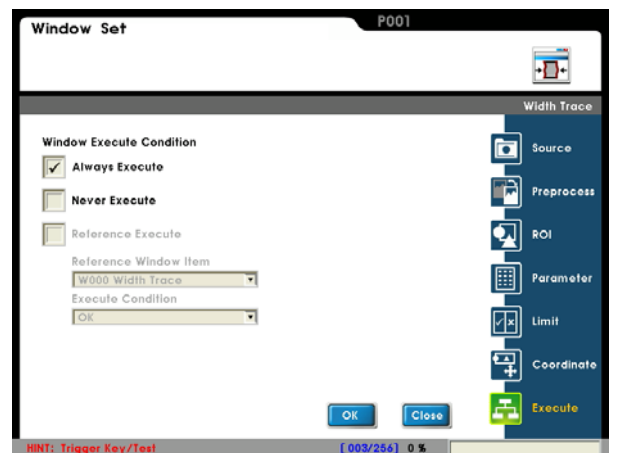

6.14 Mark

6.14.1 What is [Mark]?

The Mark function overlays the line, pattern, or text information on the detection result screen. You can select the position, size, and color of the mark. This helps make the detection results and differences more easily discernible.

6.14.2 Example application of [Mark]

The following picture shows drawing a line across the pins to use as reference to judge the lengths.

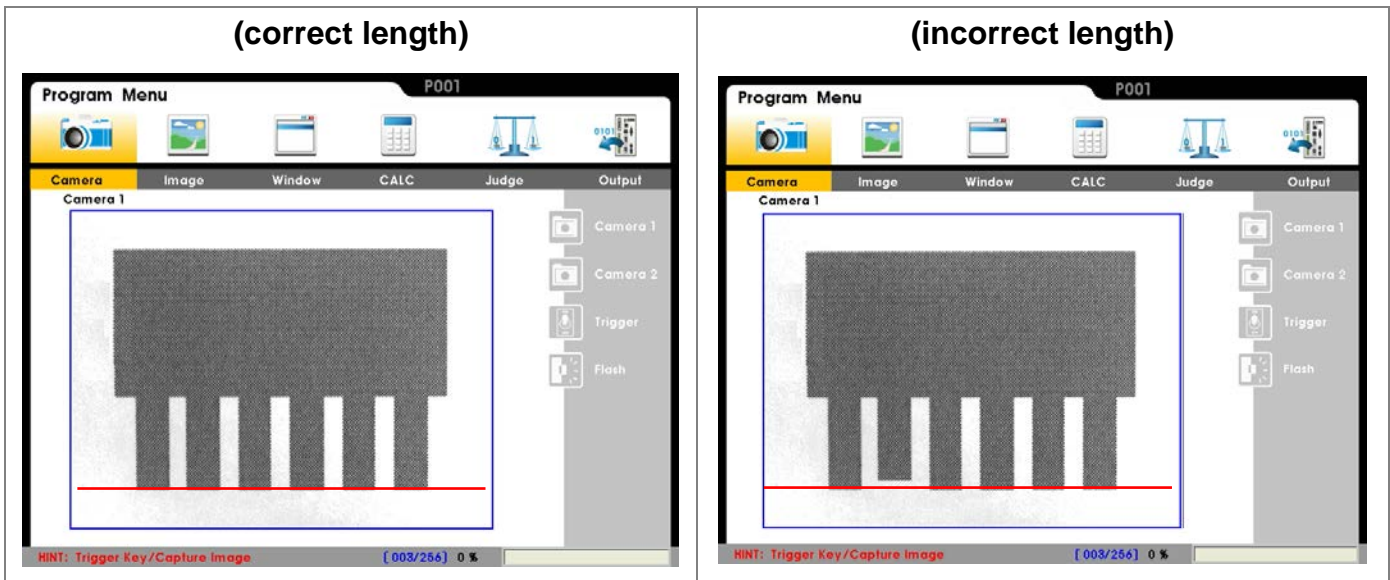

■ Application:

The function draws the red line mark over the test object. You can easily observe defects not only from the numbers, but also from the display.

6.14.3 Application setting of [Mark]

- From [Select Function], select [Mark].

Select [Edit] or [New].

Set up the following in sequence: [Source], [Graphic], [Text], and [Execute].

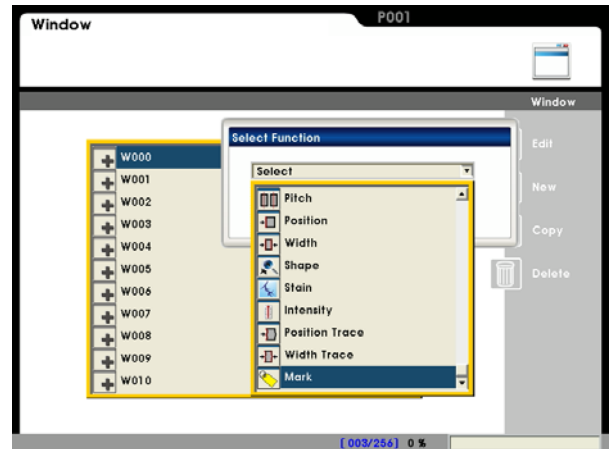

- Item 1: [Source]

Select camera

The systems supports up to two cameras simultaneously.

Select Camera 1 or Camera 2 for this detection.

Select image

Select a pre-captured image as the reference sample for this detection.

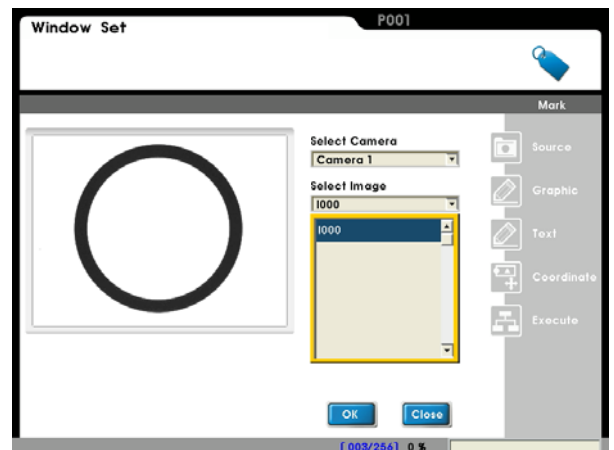

- Item 2: [Graphic]

You can specify up to five imaging objects on the detection result screen with custom shape, color, line thickness, and position.

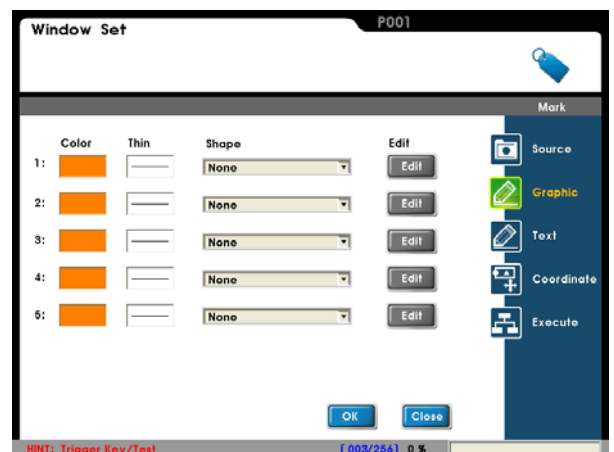

■ Item 3: [Text]

Set the text (alphanumerical only) on the result screen with custom color and position.



■ Item 4: [Execute]

Execute or disable the [Window] function.

[Always Execute]: Always execute the current [Window] while running.

[Never Execute]: Never execute the current [Window] while running. This is useful during initial testing.

[Reference Execute]: Set the [Reference Window Item] and [Execute Condition] for flow control. Execution of [Window] is determined by the OK/NG results of the prior inspections.

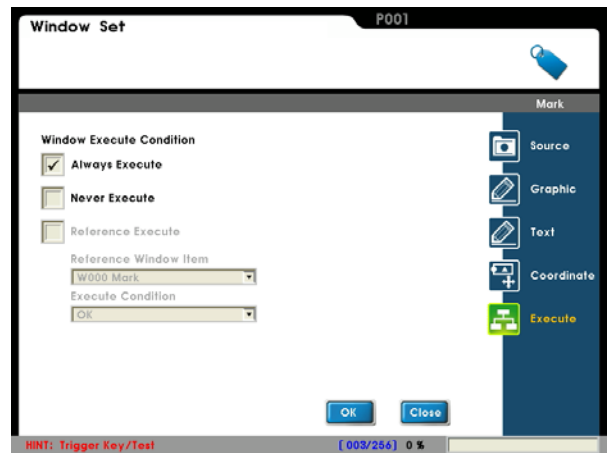

6.15 Smear Detection

6.15.1 What is [Smear Detection]

Smear Detection and Blob Detection are similar in that they calculate black/white pixel clusters, which are determined to be a smear if they fall in a certain range. The main difference is that smear detection allows more detailed adjustment of smear conditions for detection.

As shown in the figure below, the size of the smear is 4-16 pixels. Assuming the smallest contamination area is limited to 4, then the three smears in the figure will be found. If the smallest contamination area is limited to 10, then only the left and right smears will be found by the smear detection function.

The largest and smallest smears found will be displaced, and area information will be displayed according to the reference in the parameter settings.

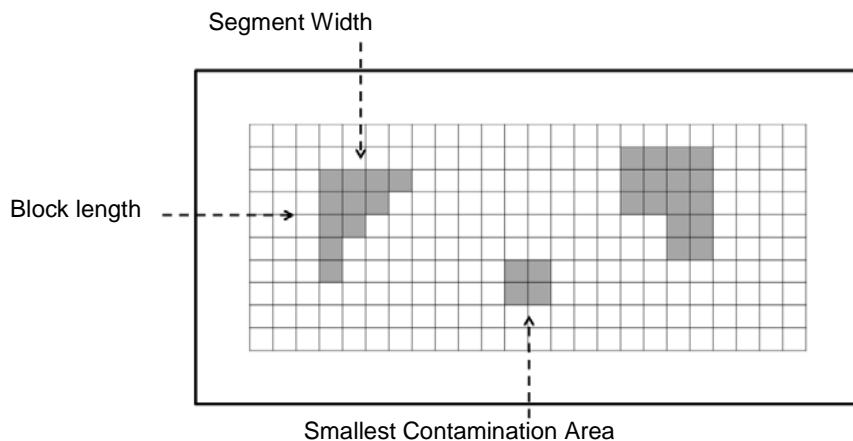

6.15.2 Detection Result

Smear detection output report

■ "Value" Output

- Total area of smears found: Range: 0 - 999999
- Number of smears found: Range: 0 - 999
- Area of specific smear: Range: 0 - 999999
 - Largest smear found: Range: 0 - 999999
 - Smallest smear found: Range: 0 - 999999
 - X and Y coordinates of the centers of all smears

For a 0.3 megapixel camera: (640 x 480)	For a 0.8 megapixel camera: (1024 x 768)
X (horizontal) coordinates: 0 - 639	X (horizontal) coordinates: 0 - 1023
Y (vertical) coordinates: 0 - 479	Y (vertical) coordinates: 0 - 767

Chapter 6: Inspection Setting

- Largest and smallest X and Y coordinates of the centers of all smears
For a 0.3 megapixel camera: (640 x 480); For a 0.8 megapixel camera: (1024 x 768)
X (horizontal) coordinates: 0 - 639 X (horizontal) coordinates: 0 - 1023
Y (vertical) coordinates: 0 - 479 Y (vertical) coordinates: 0 - 767

■ "Logic output (OK/NG)"

- Number of smears, horizontal position, vertical position, area of specific smear, and total area of smears.

When used with [Limit] for the above, the detection result is OK=1 if the limit is satisfied; otherwise it is NG=0.

6.15.3 [Smear Detection] Application Example

As shown in the figure below, inspect the surrounding area of the character for flaws, and then mark the position of flaws.

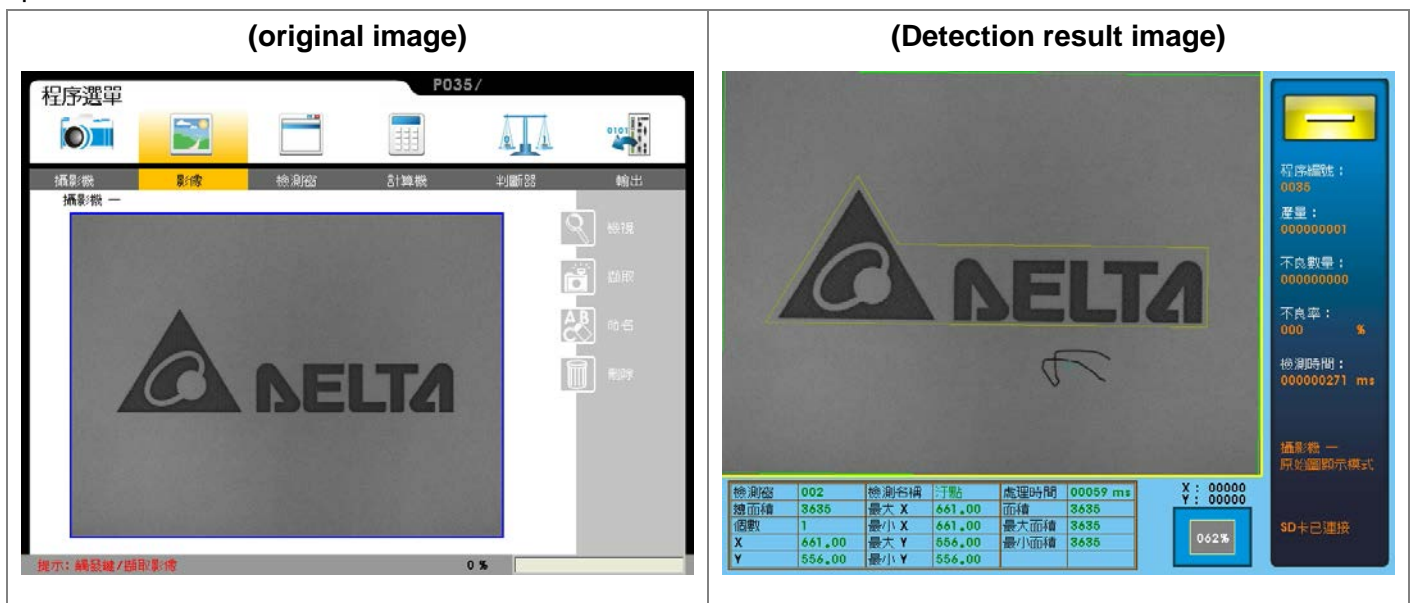

■ Inspection method

Configure a smear detection function and set the search range as the entire screen. Due to other text being on the screen, use a mask to cover the text to prevent misjudgment. After detection is completed, the system will output the number of smears found, area, and coordinates, displayed in the information field on the screen.

6.15.4 [Smear Detection] Settings

- Select the [Smear Detection] function in the [Inspection window] options.

Select [Edit] or [Add].

Set up the following items in sequence: [Source], [Pre-processing], [ROI], [Parameter], [Limit], [Coordinate], and [Execute].

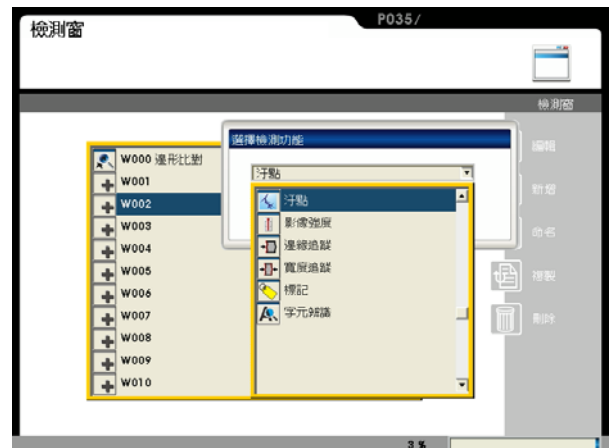

- Item 1: [Source]

Select camera:

Up to two cameras are supported simultaneously. Please select Camera 1 or Camera 2 for this detection.

Select image:

Select a pre-captured image as the reference sample for this detection.



- Item 2: [Pre-processing]

A software filter is used to first enhance the image in order to better meet the requirements. Thus, an appropriate pre-processing filter can improve accuracy and reliability of the inspection.

More than a dozen pre-processing filters are provided, including binarization, expansion, erosion, etc.

Up to six pre-processing filters (numbered 1 - 6) can be applied in order.



Reference Refer to Chapter 11 for more information about pre-processing.

■ Item 3: [ROI]

ROI:

A smaller ROI requires less detection time.

You can draw different measurement window shapes, including rectangles, circles, polygons, ellipses, rings, sectors and rotated rectangles.

Reference Refer to Section 3.2 [Draw ROI (Region Of Interest)].



Mask 1-Mask 4:

The mask is the area to be excluded from measurement. A mask can be set within the [ROI] to exclude an area from detection.

Each [Inspection window] program supports up to four masks.

You can draw different mask shapes, such as rectangles, circles, polygons, ellipses, rings, sectors and rotated rectangles.

■ Item 4: [Parameter]

Direction: The method for smear detection can be configured here, and is mainly divided into scanning horizontal, vertical, or horizontal-vertical directions.

Sort Rule: When more than one smear is detected, Sorting rules can be selected to determine which smear will be listed first.

Segment Width: Set the range to be detected for horizontal detection.

Block length: Set the range to be detected for vertical detection.

Segment Offset: Set the distance of displacement after each detection is completed.

Contamination Threshold: Adjusting this parameter can determine the level of contamination to be detected; a lower value is stricter.

Smallest Contamination Area: Set the smallest smear area to be detected.

Reference: If multiple smears are found, set the n-th result to show as the reference [Limit].

Quantity: Set the upper limit of smears that can be detected.

Origin: Define the position of the origin.

Item 5: [Limit]

Set the range for OK/NG detection. The result is OK if within the limit and NG otherwise.

Factory defaults to maximum range and thus the result is 1 (OK).

This logic flag OK=1 and NG=0 can be passed onto the subsequent [Judge] program.

Reference Refer to Chapter 7 for a detailed description of [Judge].



Item 6: [Coordinate]

Specify whether the function adjusts the coordinates (X/Y) and angle (Theta) to match the [Inspection window] result in the [ROI] window. As shown to the right, the window X/Y/θ parameters will be automatically adjusted to the [Match pattern] detection results.

The [ROI] and [Mask 1]-[Mask 4] can be configured for the detection window.

Reference Refer to Section 6.9 for more information on coordinates.

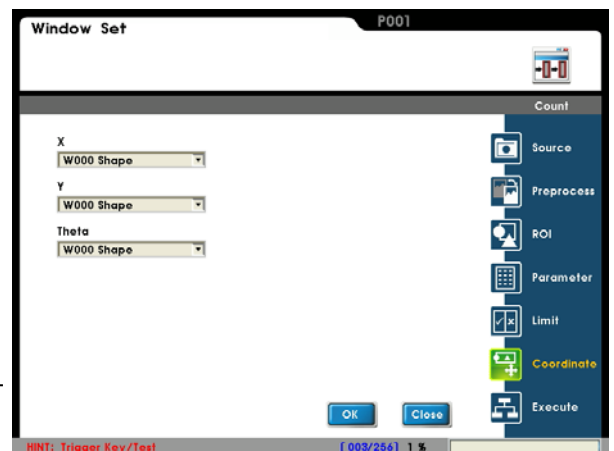

Item 7: [Execute]

Execute or disable the [Inspection Window] function.

[Always Execute]: Always execute the current [Inspection Window] while running.

[Never Execute]: The current [Inspection Window] will never be executed while running. This is useful during initial testing.

[Reference Execute]: Set the [Reference Window Item] and [Execute Condition] for flow control. Execution of [Inspection Window] is determined by the conditions above.

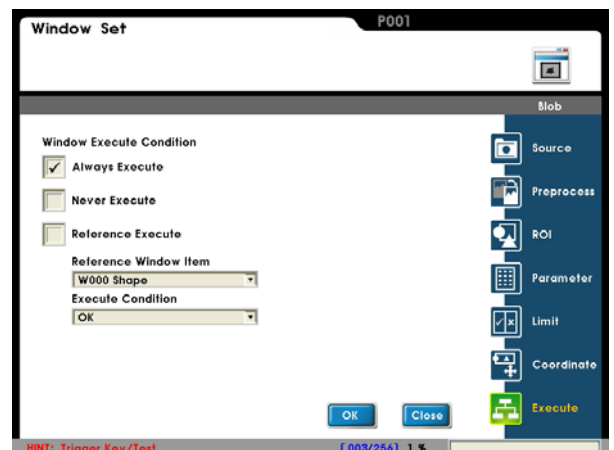

6.16 OCV

6.16.1 What is [OCV]

OCV is a function for comparing characters and searches the ROI through font outlines to detect the number of characters. Each character is then automatically (through the system) or manually divided and added to the dictionary. All objects subsequently appear in the ROI that are potentially characters will be compared to the established characters. The characters will then be recognized as the designated characters in the dictionary in cases of high degrees of similarity.

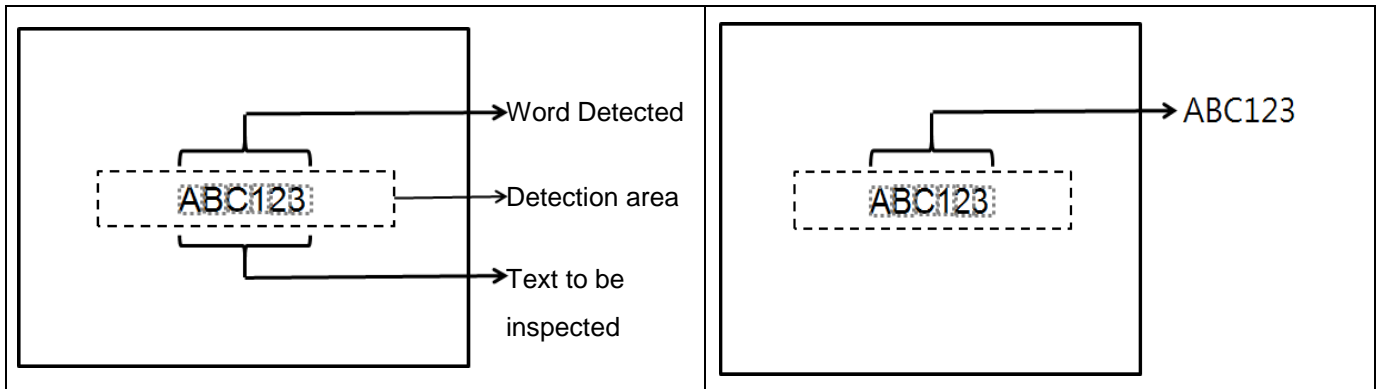

6.16.2 Detection Result

OCV results provide the following output contents

■ "Value" Output

- 1st Row String:

String Mode: General/Date

String Content 1: Input any content as the standard string for comparison; the format is limited to English letters, numbers, and some punctuations.

String Content 2: Input any content as the standard string for comparison; the format is limited to English letters, numbers, and some punctuations.

Numerical Range of Similarity: 0 - 100.00

Numerical Range of Stability: 0 - 100.00

- 2nd Row String:

String Mode: General/Date

String Content 1: Input any content as the standard string for comparison; the format is limited to English letters, numbers, and some punctuations.

String Content 2: Input any content as the standard string for comparison; the format is limited to English letters, numbers, and some punctuations.

Numerical Range of Similarity: 0 - 100.00

Numerical Range of Stability: 0 - 100.00

■ "Logic output (OK/NG)"

- Number of characters in row: Outputs the total number of characters identified by the system in the first row.
- Row string: Outputs the result obtained by the system from the strings in the first row.
When used with [Limit] for the above, the detection result is OK=1 if the limit is satisfied; otherwise it is NG=0.

6.16.3 [OCV] Application Example

Registered characters are recognized as shown in the figure below.

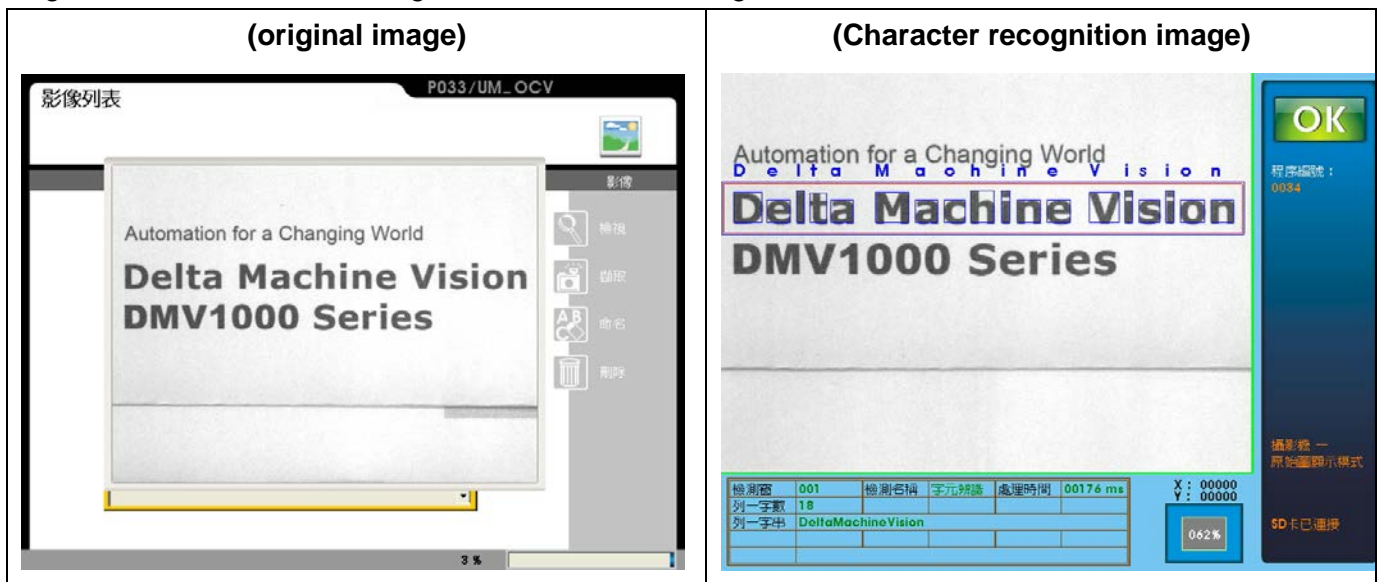

■ Inspection method

Match pattern is carried out for preliminary positioning, reference positioning results, and use OCV to find characters. As shown above when used with a [Limit], the result is OK when the characters detected are "DeltaMachineVision", and the result is NG when the characters are incorrect.

6.16.4 [OCV] Settings

- Select the [OCV] function from the [Inspection window] options.

Select [Edit] or [Add].

Set up the following items in sequence: [Source], [Pre-processing], [ROI], [Parameter], [Limit], [Coordinate], and [Execute].

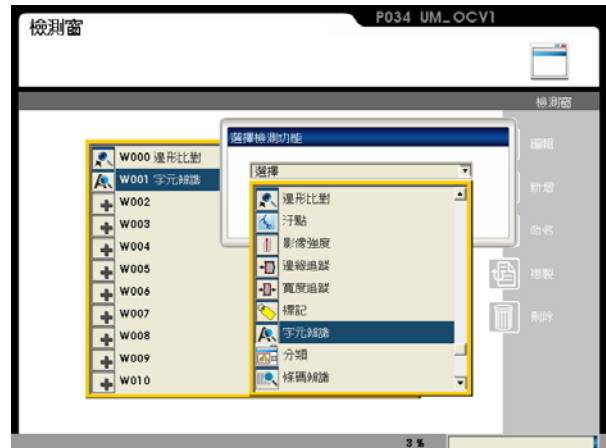

- Item 1: [Source]

Select camera:

Up to two cameras are supported simultaneously. Please select Camera 1 or Camera 2 for this detection.

Select image:

Select a pre-captured image as the reference sample for this detection.



- Item 2: [Pre-processing]

A software filter is used to first enhance the image in order to better meet the requirements. Thus, an appropriate pre-processing filter can improve accuracy and reliability of the inspection.

More than a dozen pre-processing filters are provided, including binarization, expansion, erosion, etc.

Up to six pre-processing filters (numbered 1 - 6) can be applied in order.

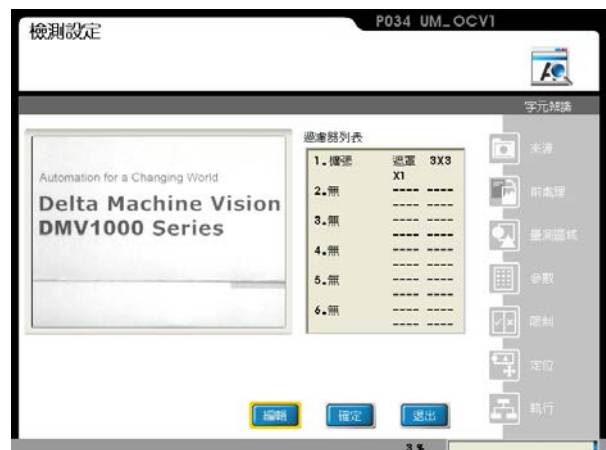

Reference Refer to Chapter 11 for more information about pre-processing.

■ Item 3: [ROI]

ROI:

Set the ROI for edge detection.

The Character Recognition is only available with the rectangular window.

 **Reference** Refer to Section 3.2 [Draw ROI (Region Of Interest)].



Mask 1-Mask 4:

The mask is the area to be excluded from measurement. A mask can be set within the [ROI] to exclude an area from detection.

In the example to the right, the top left red rectangle is a mask.

Each [Inspection window] program supports up to four masks.

You can draw different mask shapes, such as rectangles, circles, polygons, ellipses, rings, sectors and rotated rectangles.



■ Item 4: [Parameter]

Character Recognition Settings:

Set the direction of characters and adjust characters to more accurately cut characters.

Character Registration:

Can create characters into the dictionary; the format is limited to English letters, numbers, and some punctuations.



OCV

Verification Mode: Select [Smart Mode], [Manual Mode], or [Enhanced Mode] here.

Character Direction: Four methods are supported, including [Left to Right], [Right to Left], [Up to Down], and [Down to Up].

Detect Character: This item provides the option to read black or white characters in gray scale images.

Row Number: The number of rows of strings to be detected within the selected ROI can be configured here. The range can be configured to 1 - 2 rows.

Character Rotation Correction:

The correctness of character cutting can be improved by rotating characters. When the characters can be rotated, enable this function to increase the stability of recognition. The range of rotation that can be calibrated is $\pm 10^\circ$.

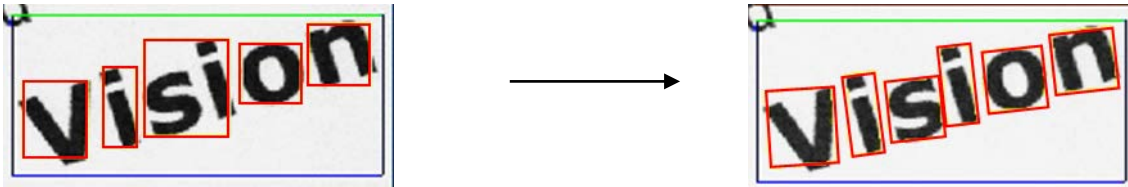

Waveform Enhancement:

Used to reduce the wave trough projected by characters. When each character has close gap distance, this item can be used to strengthen character cutting, making it easier to set the threshold.

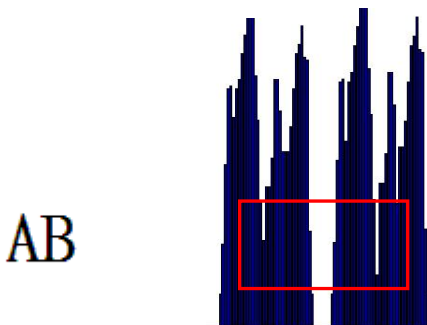

Difference of AB character projection before and after adjustment

Row1 Number: The range of the string length to be detected can be set between 1 and 22.

Row2 Number: The range of the string length to be detected can be set between 1 and 22.

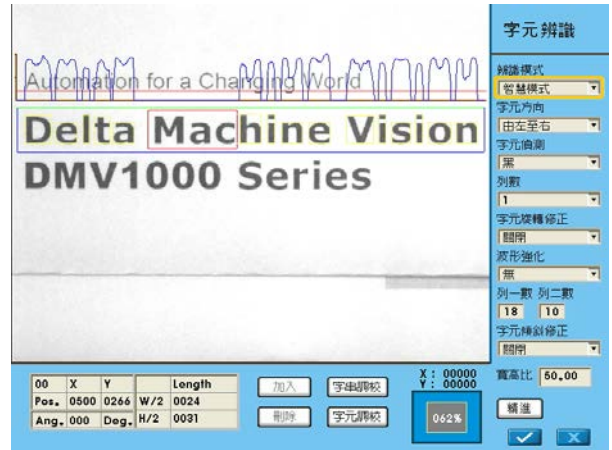

Character Tilt Correction: Calibrates tilted characters (italicized) and can cut out the frame (yellow) based on the tilted angle to match the outline of the text. When characters are tilted and cannot be cut or recognition is unstable, please enable this function to improve recognition. The current range of tilting that can be calibrated is $\pm 45^\circ$.

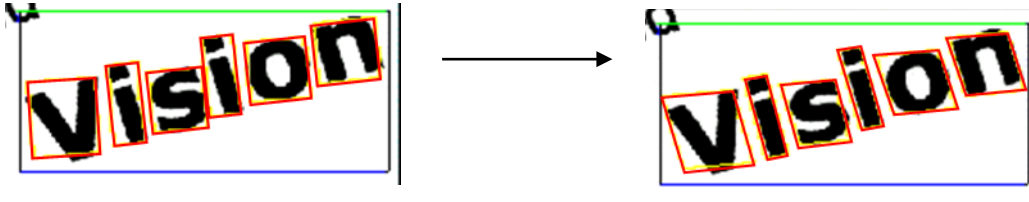

Width to height ratio: The ratio of the character width to its height; the range that can be set is 0.01-100. The default value is 50, meaning that the maximum width of a character is 50 times the maximum height of the character. Hence, if the character's width is greater than its height (e.g. W), then the width to height ratio must be increased (recommended to be > 1).

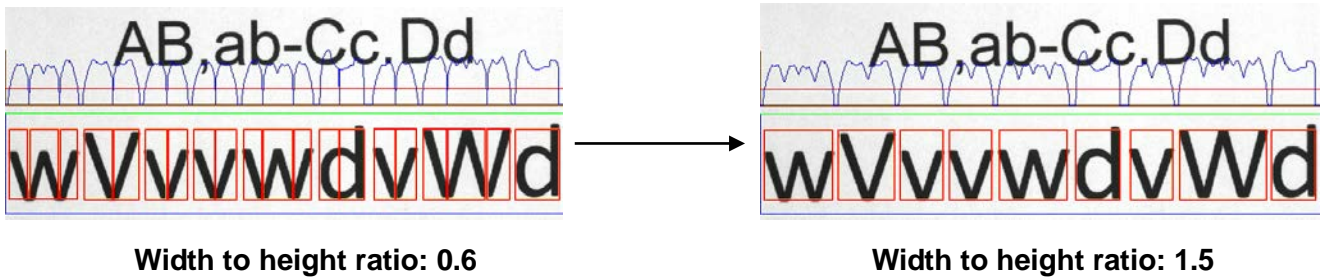

Improve

Exclusion mode:

When this function is enabled, the system will only output characters with a greater degree of similarity. As shown in the example below: When the character being recognized is damaged or covered, users do not want to output incorrect results. Hence, by registering correct characters in the dictionary and enabling this function, the system will not output the character when the defective number or character's similarity is lower than the limit set by the user (the red characters in the figure below indicates that it is lower than the limit).

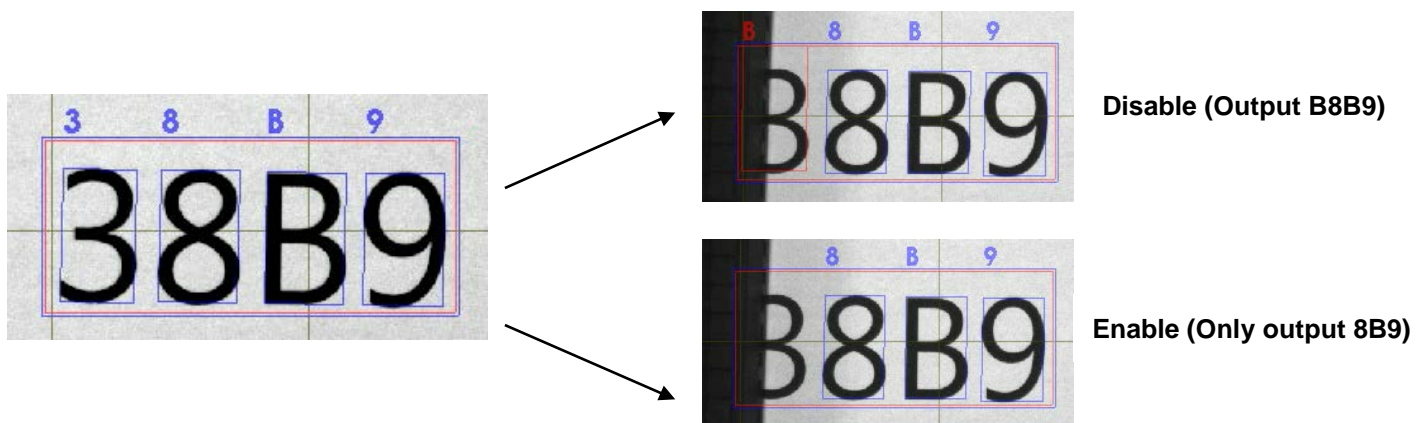

Lower case:

When it is hard to configure the projection due to the characters having a combination of upper and lower case letters, enable this function and the system will search for characters based on the range of characters that are cut.

As shown in the example below: The projection of "y" is lower than other characters and can easily result in failed character cutting. When this function is enabled, the system will search for the range of individual characters again.

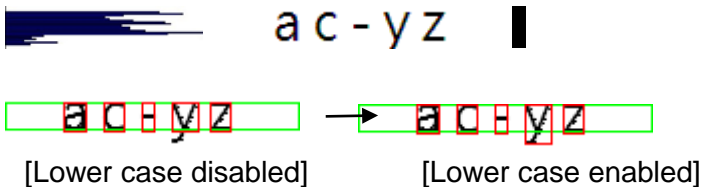

Level Characters:

Cut all characters to the same height. Used to detect symbols in characters, such as ":", ";", "-"... Enable this function to improve recognition stability.

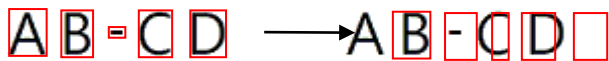

String Adjust, Character Adjust

Threshold: When an object in the ROI exceeds the configured threshold, the object will be recognized as a string by the system. When this string is poorly cut, this threshold can be lowered to improve the accuracy of string cutting.

Lower: Mainly filters fine noise signals from images. Lower parameters can be adjusted between a range of 0 and 100. Waves smaller than the configured value of Lower will disappear in the waveform.

Character Minimum Width: The minimum width of a single character can be configured with the adjustment range of 0-1024.

Character Maximum Width: The maximum width of a single character can be configured with the adjustment range of 0-1024.

The width of the character must match: Minimum width of character \leq Character width \leq Maximum width of character, the character will not be output if the character width is not within this range.

Smoothing: RGB Grayscale of edges can be set between 0 and 10 for calculations. When Smoothing is increased, Slope of waveform changes, thereby attenuating the effect caused by noise signals.

Character Registration: Each character can be established in order into the dictionary by clicking this item. If the first detected character is "A", then configure [Character Selection] to 1 and fill in "A" in the [Character] item and click OK. This completes registering the first character.

String1 registration: This item registers the first string. Click this item, fill in the contents of the first string, and click OK to complete string register.

String2 registration: This item registers the second string. Click this item, fill in the contents of the second string, and click OK to complete string register.

Set up origin:

Select [Edit] to open the Origin Menu.

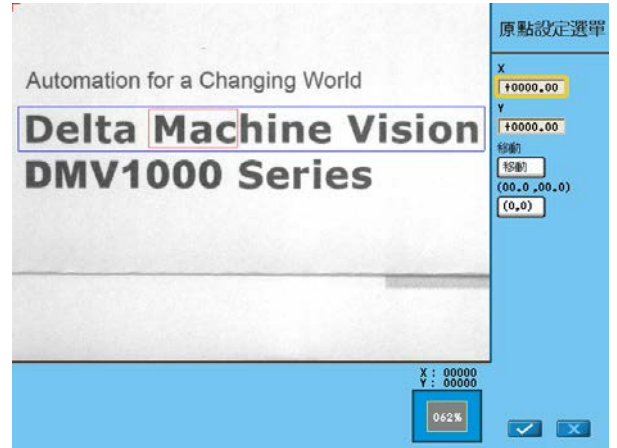

Item 5: [Limit]

Set the range for OK/NG detection. The result is OK if within the limit and NG otherwise.

Factory defaults to maximum range and thus the result is 1 (OK).

This logic flag OK=1 and NG=0 can be passed onto the subsequent [Judge] program.

Reference Refer to Chapter 7 for a detailed description of [Judge].



Item 6: [Coordinate]

Specify whether the function adjusts the coordinates (X/Y) and angle (Theta) to match the [Inspection Window] result in the [ROI] window. Inspection windows that can be used for reference include match pattern, pattern comparison, position, and edge angle.

The [ROI] and [Mask 1]-[Mask 4] can be configured for the detection window.

After selecting [Capture], the XY coordinates of the edge position can be used as reference for subsequent programs.

When Center Display is open, it will indicate the coordinates or angle of the current center in the screen and the difference with the registered image. The RGB below can be used to modify the color of markings.

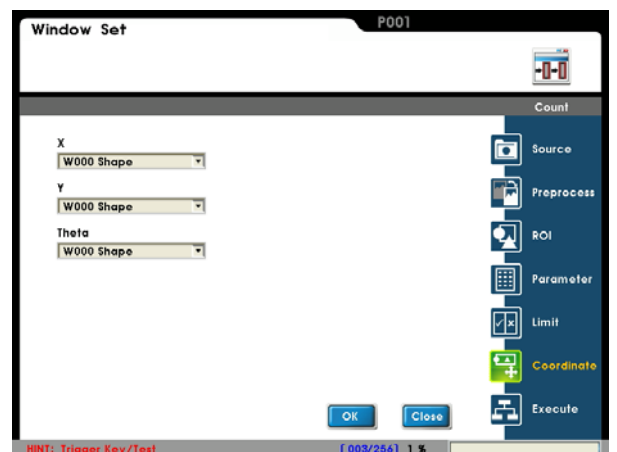

■ Item 7: [Execute]

Execute or disable the [Inspection Window] function.

[Always Execute]: Always execute the current [Inspection Window] while running.

[Never Execute]: The current [Inspection Window] will never be executed while running. This is useful during initial testing.

[Reference Execute]: Set the [Reference Window Item] and [Execute Condition] for flow control. Execution of [Inspection Window] is determined by the conditions above.



■ Item 8: [Output Item]

- 1) High (N): Outputs the total number of characters detected by the system.
- 2) Row1 Number of Characters (R1N): Outputs the total number of characters identified by the system in the first row.
- 3) Row2 Number of Characters (R2N): Outputs the total number of characters identified by the system in the second row.
- 4) OCV_String1 (R1S): Outputs the result obtained by the system from the strings in the first row.
- 5) OCV_String2 (R2S): Outputs the result obtained by the system from the strings in the second row.
- 6) Row1 Start X of Character (X1S): Outputs the starting X coordinate of the designated character found by the system from the strings in the first row.
- 7) Row1 End X of Character (X1E): Outputs the ending X coordinate of the designated character found by the system from the strings in the first row.
- 8) Row1 Start Y of Character (Y1S): Outputs the starting Y coordinate of the designated character found by the system from the strings in the first row.
- 9) Row1 End Y of Character (Y1E): Outputs the ending Y coordinate of the designated character found by the system from the strings in the first row.
- 10) Row1 Character Recognition Result (C1): Outputs the result of the designated character found by the system from the strings in the first row.
- 11) Row1 Similarity of Character (S1): Outputs the degree of similarity of the designated character found by the system from the strings in the first row.
- 12) Row2 Start X of Character (X2S): Outputs the starting X coordinate of the designated character found by the system from the strings in the second row.
- 13) Row2 End X of Character (X2E): Outputs the ending X coordinate of the designated character found by the system from the strings in the second row.
- 14) Row2 Start Y of Character (Y2S): Outputs the starting Y coordinate of the designated character found by the system from the strings in the second row.
- 15) Row2 End Y of Character (Y2E): Outputs the ending Y coordinate of the designated character found by the system from the strings in the second row.

- 16) Row2 Character Recognition Result (C2): Outputs the result of the designated character found by the system from the strings in the second row.
- 17) Row2 Similarity of Character (S2): Outputs the degree of similarity of the designated character found by the system from the strings in the second row.
- 18) Row1 Maximum X (X1H): Outputs the largest X coordinate in all characters found by the system from the strings in the first row.
- 19) Row1 Minimum X (X1L): Outputs the smallest X coordinate in all characters found by the system from the strings in the first row.
- 20) Row1 Maximum Y (Y1H): Outputs the largest Y coordinate in all characters found by the system from the strings in the first row.
- 21) Row1 Minimum Y (Y1L): Outputs the smallest Y coordinate in all characters found by the system from the strings in the first row.
- 22) Row2 Maximum X (X2H): Outputs the largest X coordinate in all characters found by the system from the strings in the second row.
- 23) Row2 Minimum X (X2L): Outputs the smallest X coordinate in all characters found by the system from the strings in the second row.
- 24) Row2 Maximum Y (Y2H): Outputs the largest Y coordinate in all characters found by the system from the strings in the second row.
- 25) Row2 Minimum Y (Y2L): Outputs the smallest Y coordinate in all characters found by the system from the strings in the second row.
- 26) Row1 Maximum Similarity (S1H): Outputs the value of the highest degree of character similarity among all characters found by the system from the strings in the first row.
- 27) Row1 Minimum Similarity (S1L): Outputs the value of the lowest degree of character similarity among all characters found by the system from the strings in the first row.
- 28) Row2 Maximum Similarity (S2H): Outputs the value of the highest degree of character similarity among all characters found by the system from the strings in the second row.
- 29) Row2 Minimum Similarity (S2L): Outputs the value of the lowest degree of character similarity among all characters found by the system from the strings in the second row.

6.17 Classification

6.17.1 What is [Classification]

The classification function allows up to 12 different default patterns to be searched for in the area, identifying which type of pattern it is for classification. It can also output the XY coordinates and θ angle of all patterns found.

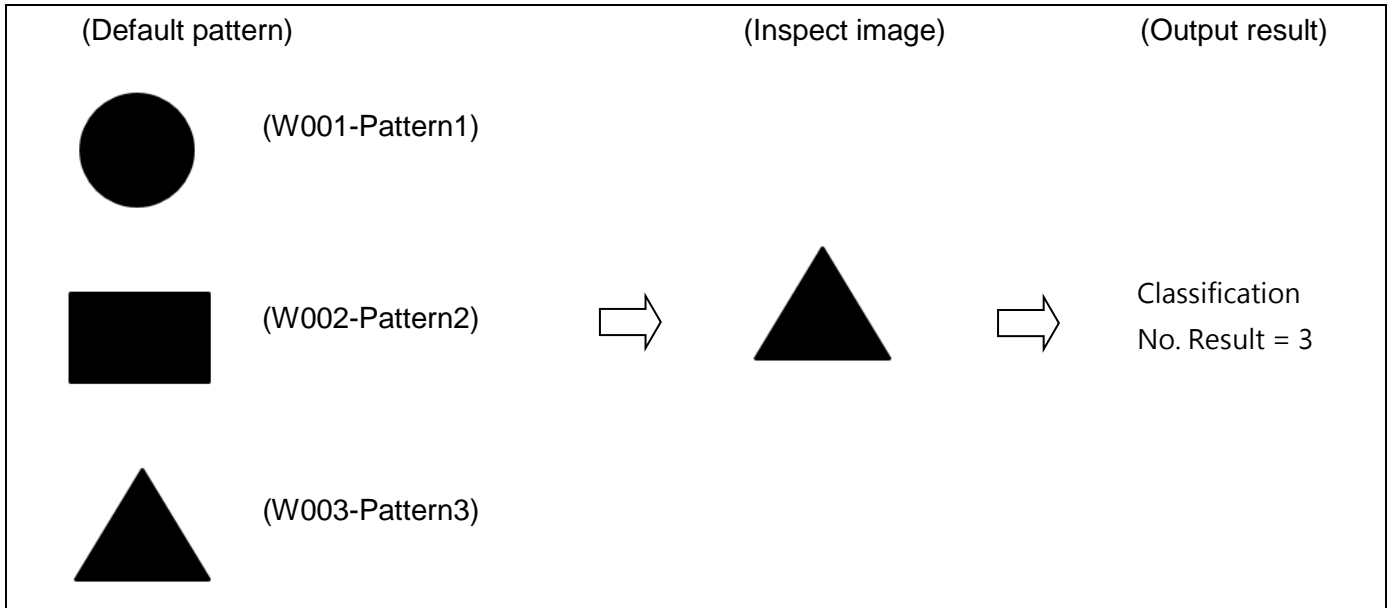

6.17.2 Detection Result

Classification inspection results provide the following output contents

■ "Value" Output

- Found: 0 - 999

Object search results are shown below, and the order of search is designated using [Reference].

- For a 0.3 megapixel camera: (640 x 480)
 - X (horizontal) coordinates: 0 - 640
 - Y (vertical) coordinates: 0 - 480
- For a 0.8 megapixel camera: (1024 x 768)
 - X (horizontal) coordinates: 0 - 1024
 - Y (vertical) coordinates: 0 - 768
- Similarity: 0 - 100.00
- θ (rotation) angle: -180.00 - +180.00

■ "Logic output (OK/NG)"

- Detection result: A successful detection is 1 = OK; otherwise the result is 0 = NG.
- Found: When used with [Limit], the detection result is OK=1 if within the limit; otherwise it will be NG=0.
- Similarity: When used with [Limit], the detection result is OK=1 if within the limit; otherwise it will be NG=0.
- θ (rotation) angle: When used with [Limit], the detection result is OK=1 if within the limit; otherwise it will be NG=0.
- X (horizontal) coordinates: When used with [Limit], the detection result is OK=1 if within the limit; otherwise it will be NG=0.
- Y (vertical) coordinates: When used with [Limit], the detection result is OK=1 if within the limit; otherwise it will be NG=0.

6.17.3 [Classification] application example

Using the default patterns [Circle W001], [Rectangle W002], and [Triangle W003] above as an example, the actual detection results are shown below.

(Circle – Inspection Classification No. Result = 1)

檢測窗	005	檢測名稱	分類	處理時間	00408 ms	X : 00000	Y : 00000
函數	1	角度	-22.34	最大 Y	360.23	0.62%	
相似度	99.42	編號	1	最小 Y	360.23		
X	509.68	最大 X	509.68				
Y	360.23	最小 X	509.68				

(Rectangle – Inspection Classification No. Result = 2)

檢測窗	005	檢測名稱	分類	處理時間	00204 ms	X : 00000	Y : 00000
函數	1	角度	25.46	最大 Y	444.86	0.62%	
相似度	99.84	編號	2	最小 Y	444.86		
X	575.78	最大 X	575.78				
Y	444.86	最小 X	575.78				

■ Inspection method

The configuration method is the same as [Match pattern]. Create [Match pattern W001 circle pattern], [Match pattern W002 rectangle pattern], and [Match pattern W003 triangle pattern].

In the [Classification] function, import these 3 [Match pattern] and the classification function will use the patterns as the basis for classification, determining which pattern the image matches (displays the number).

Note: Classification results that are output are the inspection window ID Wxxx.

6.17.4 [Classification] Detection Settings

- In the [Inspection window] options, create multiple [Match pattern] functions (create classification patterns).

The purpose of configuring the match pattern function is to create the patterns needed for classification. Hence, if there are three types of classification images, then three match pattern inspection windows must be created, and select different patterns for each compare function.

Reference Refer to Section 6.9 for how to configure [Match pattern].

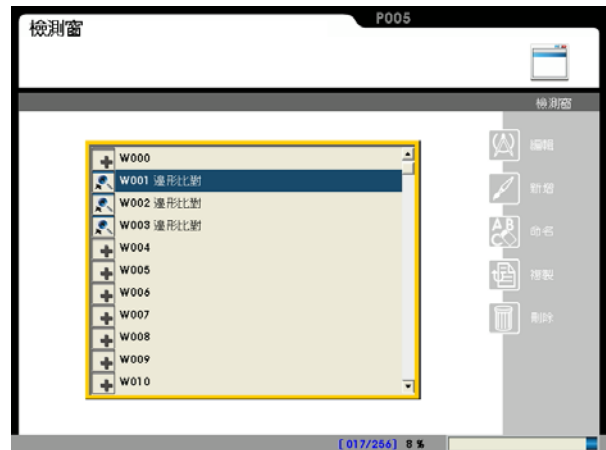

- Select the [Classification] function from the [Inspection window] options.

Select [Edit] or [Add].

Set up the following items in sequence: [Source], [Pre-processing], [ROI], [Parameter], [Limit], [Coordinate], and [Execute].



- Item 1: [Source]

Select camera:

Up to two cameras are supported simultaneously. Please select Camera 1 or Camera 2 for this detection.

Select image:

Select a pre-captured image as the reference sample for this detection.

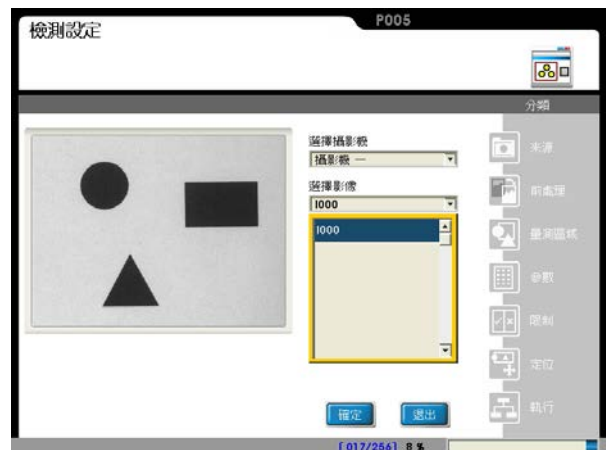

■ Item 2: [Pre-processing]

A software filter is used to first enhance the image in order to better meet the requirements. Thus, an appropriate pre-processing filter can improve accuracy and reliability of the inspection.

More than a dozen pre-processing filters are provided, including binarization, expansion, erosion, etc.

Up to six pre-processing filters (numbered 1 - 6) can be applied in order.

Reference Refer to Chapter 11 for more information about pre-processing.

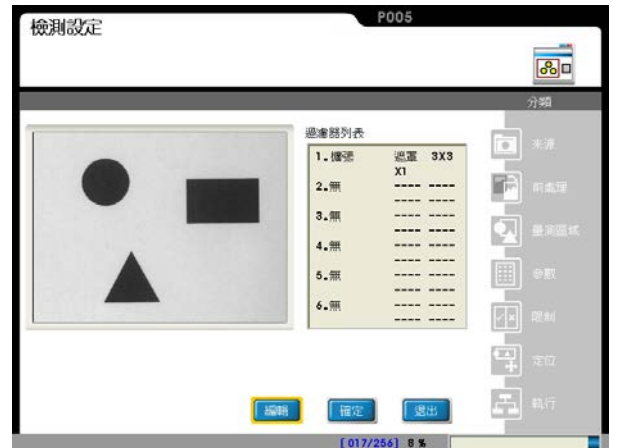

6.18 Code Reader

6.18.1 What is [Code Reader]

Code Reader is the function to read barcodes and 2D barcodes. The code is decoded on the screen and results are output. Types of barcodes supported include Code39, Code93, Code128, I25, EAN8, UPCE, ISBN 10, UPCA, EAN13, ISBN13 and 2D barcodes include Data Matrix and QR codes.

Currently, one detection function can only read one barcode, so when the ROI has multiple barcodes, the system will find the barcode in the best condition and decode it for output.

If there are multiple barcodes at fixed positions of the screen that need to be read, multiple barcode recognition functions can be created for different ROI in the same project.

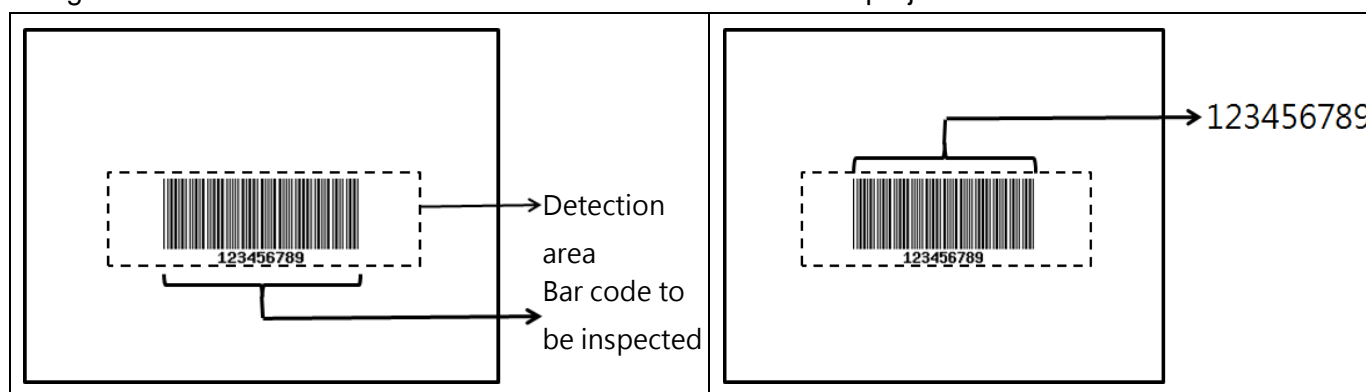

6.18.2 Detection Result

■ "Value" Output

- Barcode Length: 0-100 (up to 100 barcode characters can be read)
- Barcode Content: Select independent characters or complete strings to output.

■ "Logic output (OK/NG)"

- Detection result: A successful detection is OK = 1; otherwise the result is NG = 0. Barcode Length: Configure the upper/lower limit of the allowed length in coordination with [Limit] items, the detection result is OK=1 if within the limit; otherwise it will be NG=0.
- Barcode Content: When used with [Limit] and the characters that need to be found are set, the detection result is OK=1 if there is a match; otherwise it will be NG=0.

6.18.3 [Code Reader] Application Example

As shown in the figure below, DMV1000 reads barcodes and 2D barcodes.

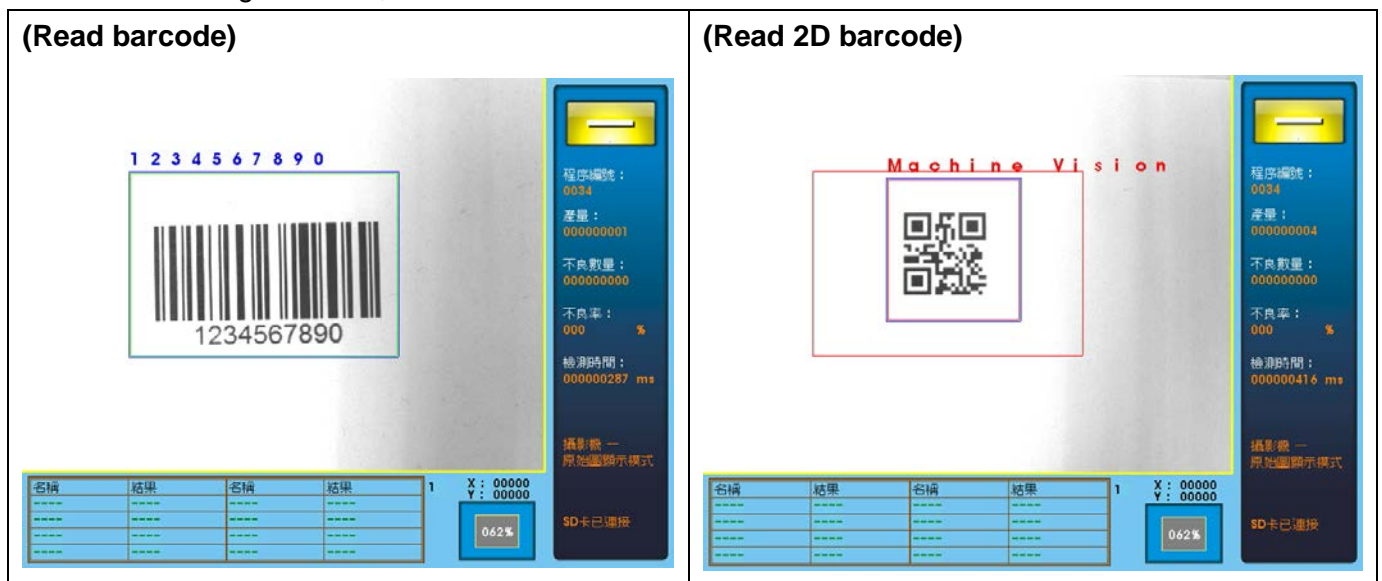

6.18.4 [Code Reader] Detection setting

- Select the [Code Reader] function from the [Inspection window] options.

Select [Edit] or [Add].

Set up the following items in sequence: [Source], [Pre-processing], [ROI], [Parameter], [Limit], [Coordinate], and [Execute].

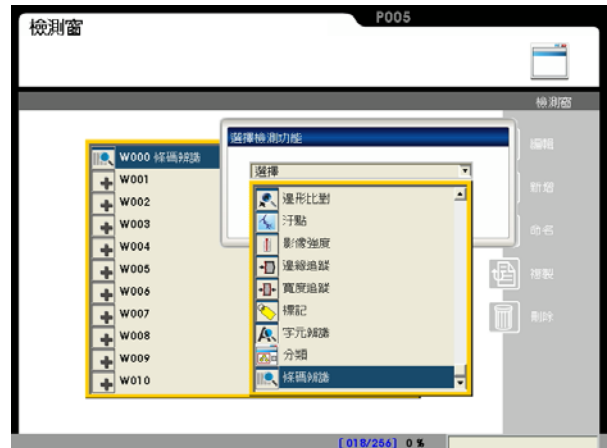

- Item 1: [Source]

Select camera:

Up to two cameras are supported simultaneously. Please select Camera 1 or Camera 2 for this detection.

Select image:

Select a pre-captured image as the reference sample for this detection.



- Item 2: [Pre-processing]

A software filter is used to first enhance the image in order to better meet the requirements. Thus, an appropriate pre-processing filter can improve accuracy and reliability of the inspection.

More than a dozen pre-processing filters are provided, including binarization, expansion, erosion, etc.

Up to six pre-processing filters (numbered 1 - 6) can be applied in order.

Reference Refer to Chapter 11 for more information about pre-processing.



Item 3: [ROI]

ROI:

A smaller ROI requires less detection time.

The Code Reader is only available with the rectangular window.

 **Reference** Refer to Section 3.2 [Draw ROI (Region Of Interest)].

Mask 1-Mask 4:

The mask is the area to be excluded from measurement. A mask can be set within the [ROI] to exclude an area from detection.

Each [Inspection window] program supports up to four masks.

You can draw different mask shapes, such as rectangles, circles, polygons, ellipses, rings, sectors and rotated rectangles.

Item 4: [Parameter]

Code Reader Settings

Barcode type: Select whether to read barcodes or 2D barcodes.

Only one type can be selected at a time. The system currently cannot detect two types at the same time.

Barcode color: Select to read black or white barcodes.

At present, the most common type of barcode is [black barcode on white background]. Please select [Black] here. If it is the less common [white barcode on black background], these are more commonly laser carved. Please select [White].

Origin: Define the position of the origin.



Item 5: [Limit]

Set the range for OK/NG detection. The result is OK if within the limit and NG otherwise.

Factory defaults to maximum range and thus the result is 1 (OK).

This logic flag OK=1 and NG=0 can be passed onto the subsequent [Judge] program.

Reference Refer to Chapter 7 for a detailed description of [Judge].

Barcode Length: Set the upper/lower limit of the number of characters in the barcode.

The result is OK if within the limit and NG otherwise.

For example, The number of characters in a barcode should be 16 if correct. At this time, set the upper/lower limit at 16. When the number of characters detected is not equal to 16, the detection result is NG.

If the upper limit is 30 and lower limit 10, then the result is OK if the number of characters is in the range 10-30. If it is not in the range, the detection result is NG.

Barcode content setting menu:

Set the method for comparing the correctness of characters read.

Barcode data: Set the correct string contents that are to be detected. Detection results are compared with this data during RUN, and the result is OK if it is the same. If it is different, then the result is NG.

Reference: Displays the characters detected in the barcode in the current registered image, providing reference for the above [Barcode Data]. The registered image must be manually tested first before there are reference characters to display.

Ignore characters: When [Enable] is selected, if a character in [Barcode Data] is set as [!], the character will be ignored and not compared. For example, if the third character changes and should not be compared, then the third character should be set as !, and the system will ignore the character during comparison.

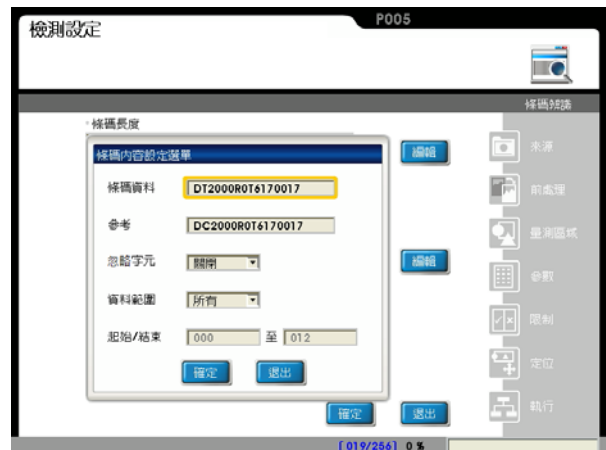

Data range: When [All] is selected, all contents of the barcode will be compared with [Barcode Data] during RUN. If [Custom] is selected, then [Start/End] below can be used to specify the range of characters to compare.

The numbers start from 0, 0 represents the first character, 1 represents the second character...

Start/End: Used when [Custom] is selected with [Data range].

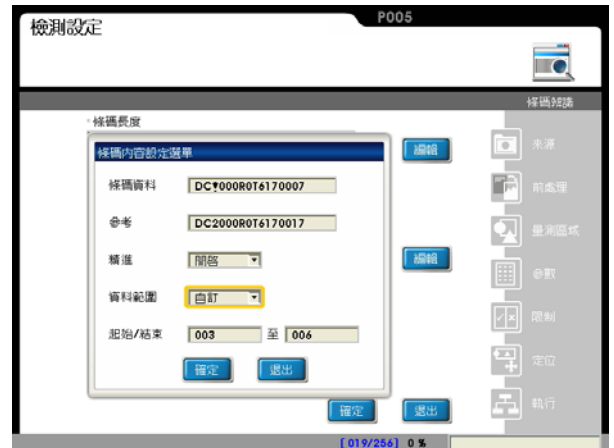

Item 6: [Coordinate]

Specify whether the function adjusts the coordinates (X/Y) and angle (Theta) to match the [Inspection window] result in the [ROI] window. As shown to the right, the window X/Y/θ parameters will be automatically adjusted to the [Match pattern] detection results.

The [ROI] and [Mask 1]-[Mask 4] can be configured for the detection window.

Reference Refer to Section 6.9 for more information on coordinates.

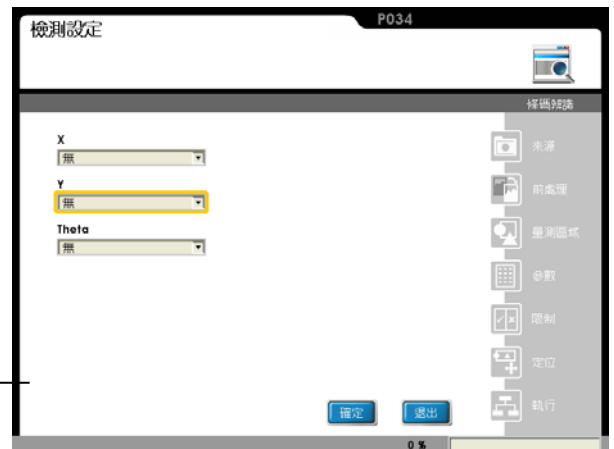

Item 7: [Execute]

Execute or disable the [Inspection Window] function.

[Always Execute]: Always execute the current [Inspection Window] while running.

[Never Execute]: The current [Inspection Window] will never be executed while running. This is useful during initial testing.

[Reference Execute]: Set the [Reference Window Item] and [Execute Condition] for flow control. Execution of [Inspection Window] is determined by the conditions above.

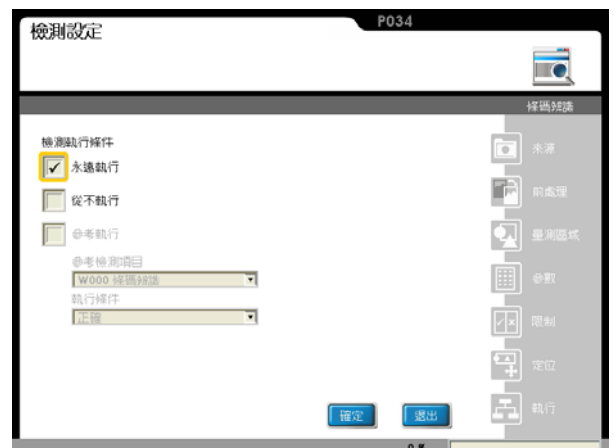

Chapter 7

Calculator, Judge, and Output

After setting up the Window functions (Chapter 6), edit the [Calculator], [Judge], and [Output] programs under [Window] in order. The main functions are listed below.

- **Calculator:** Apply arithmetic and function calculations on the [Window] data, after which this new data is passed to the subsequent [Output] program. In addition, you can restrict the calculator output to the upper and lower limits to output a logic flag that the system can pass to the subsequent [Judge] and [Output] programs.
- **Judge:** Perform Boolean logic on the [Window] and [Calculator] flags and pass the results to the subsequent [Output] program.
- **Output:** The system can output data from [Window] and [Calculator] or judgment logic from [Window], [Calculator], and [Judge] to any specific hardware interface.

7.1 What is [Calculator]?

The calculator works with the [Window] results (for example quantity, coordinates, and angle) through an arithmetic interface. For example, the calculator can add two counters with results 2 and 3 can be added together. The system can then pass the final result, 5 to the subsequent [Output] program (for example, sending the result to the PC through RS232)

In addition to simple arithmetic, the calculator also has trigonometry and coordinate functions for calculating the distance between coordinates.

Each individual project supports up to 32 calculators (C00–C31) and you can configure each calculator ID with upper and lower limits to produce a logical result. The system can pass the results to the subsequent [Judge] and [Output] programs. For example, if the standard value is 100 (with +/-1 tolerance) for a size measurement and calculation, you can set the upper and lower limits for the calculator to 101 and 99, respectively. Results in 99–101 are OK and NG otherwise.

7.2 Edit [Calculator]

7.2.1 [Calculator] interface

- Enter the [Program] menu and select the [Calculator] ID to open the editing list.

Item	Description
1	Equation display
2	Constant input
3	Select result from [Window], [Previous calc], or [Memory].
4	Built-in functions
5	Upper/lower limit

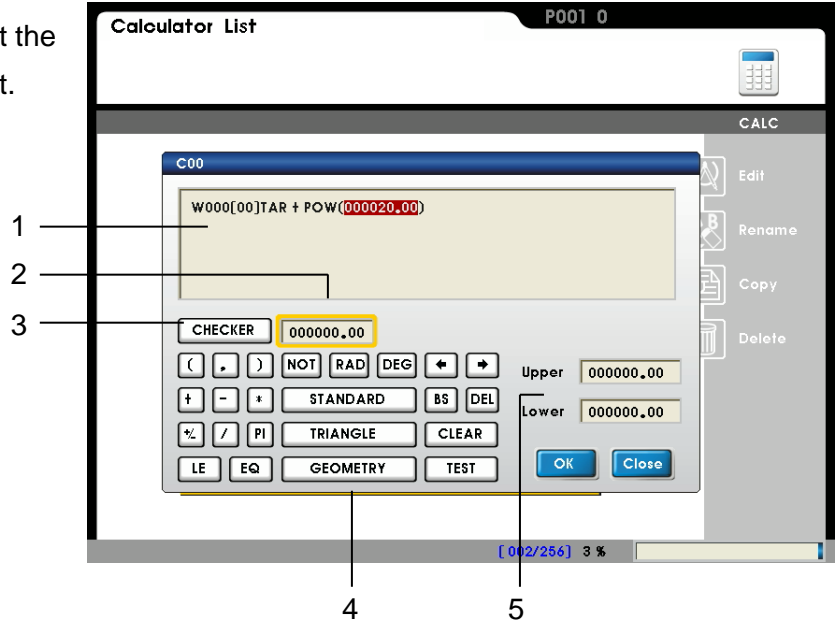

(Item 1) Equation display

Depending on the function, you can enter approximately 15 entries in the display area.

If you exceed the equation space, you can carry over the result to the next calculator ID for more calculations.

The picture to the right shows exceeding the equation space for C00 and so the C00 result 100 is called by C01 for more space (C00V).

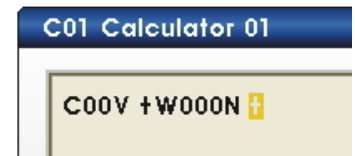

(Item 2) Constant input

Press the / / / keys to adjust the

field. Select the sign and then adjust the value for a negative number.

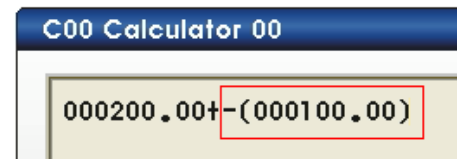

(Item 3) Select [Window] calculator value List

Press the button to select the available results from the existing [Windows]. Select the Window, and then select the function output from the Window (represented by function codes).

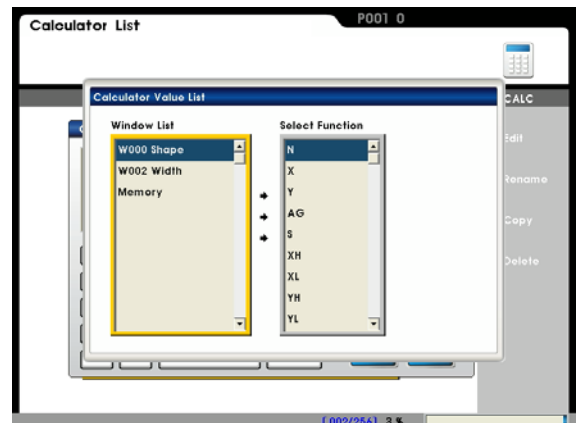

Reference Refer to Section 7.2.2 for the list of [Calculator] [Function] codes.

■ (Item 4) Built-in functions

Additional keys

Control unit	Description
BS	Use Backspace to delete the previous field.
DEL	Use Delete to delete the current field.
CLEAR	Use Clear to delete all calculator fields (with a confirmation popup window).
TEST	Get results to test current settings.

Function unit

The system supports three sets of functions (with some example functions):

- [STANDARD]: MAX, MIN, AVG, ABS, MOD, POW, SQR, SQRT, INT, ROUND
- [TRIANGLE]: (Trigonometry) SIN, COS, TAN, ASIN, ACOS, ATAN
- [GEOMETRY]: DIST, BISECT_X, BISECT_Y, LINE_DIST, LINE_DIST_X, LINE_DIST_Y, ANGLE, LINE_ANGLE, D_LINE_ANGLE, CIRCLE_X, CIRCLE_Y, CIRCLE_R

The following table describes the available functions.

Function	Description	Example	Note:
NOT	Logic function	NOT(2) = 0, BNOT(0) = 1, BNOT(-2) = 0	Returns 1 if input is 0; otherwise 0 is returned;
RAD	Convert to radians	RAD(180) = 3.14	
DEG	Convert to degrees	DEG(3.14) = 179.90	
MAX	Maximum value in a list	MAX (2,3,4) = 4	Up to 10 input elements
MIN	Minimum value in a list	MIN (2,3,4) = 2	Up to 10 input elements
AVG	Average	AVG (2,3) = 2.5, B AVG (2,3,4) = 3	Up to 10 input elements
ABS	Absolute value	ABS (-10) = 10	
MOD	Find remainder	MOD (5,2) = 1, B MOD (8,3) = 2	8 / 3 = 2 with remainder 2
POW	Power of N	POW (2,3) = 8, B POW (3,4) = 81	3 * 3 * 3 * 3 = 81
SQR	Square	SQR (2) = 4, B SQR (-2) = 4	
SQRT	Square root	SQRT (9) = 3	
INT	Find integer part	INT(123.45) = 123	
ROUND	Round up/down to the next integer	ROUND(1234.5) = 1235	
PI	π	3.14159	

Chapter 7: Calculator, Judgment, and Output

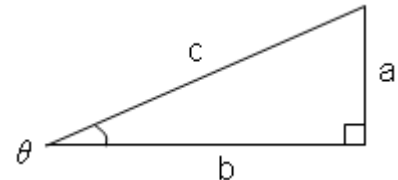
LE	Compare two elements (output 1 if first element is greater than the second)	LE (8,2) = 1 LE (2,8) = 0, BLE (2,2) = 0	8 > 2 2 < 8, 2 ≤ 2 output 0
EQ	Compare two elements (output 1 if equal)	EQ (2,2) = 1 EQ (8,2) = 0	Two elements are not equal, output 0
SIN	Sine	SIN (30) = 0.5	 <p> $SIN(\theta) = a / c$ $COS(\theta) = b / c$ $TAN(\theta) = a / b$ $ASIN(a/c) = \theta$ $ACOS(b/c) = \theta$ $ATAN(a/c) = \theta$ </p>
COS	Cosine	COS (30) = 0.866	
TAN	Tangent	TAN (30) = 0.577	
ASIN	Arcsine	ASIN (1) = 90	
ACOS	Arccosine	ACOS (1) = 0	
ATAN	Arctangent	ATAN (1) = 45	

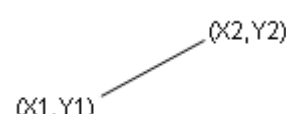
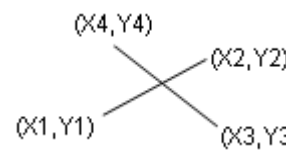
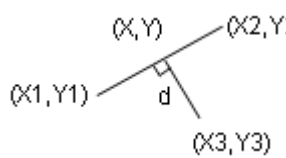
Function	Description	Example	Note:
DIST	Distance between two points (X,Y)	DIST (X1,Y1,X2,Y2) DIST (20,20,30,20) = 10 DIST (20,20,30,30) = 14.14	
ISECT_X	X coordinates of intersection between two lines	ISECT (X1,Y1,X2,Y2,X3,Y3... ISECT_X (0,0,4,4,0,4,0) = 2	
ISECT_Y	Y coordinates of intersection between two lines	ISECT (X1,Y1,X2,Y2,X3,Y3... ISECT_Y (0,0,4,4,0,4,0) = 2	
LINE_DIST	Minimum distance (d) to a line	LINE_DIST (X1,Y1,X2,Y2,X3,Y3) LINE_DIST (0,0,4,4,0,4) = 2	
LINE_DIST_X	X coordinates on the line with minimum distance to a point	LINE_DIST (X1,Y1,X2,Y2,X3,Y3) LINE_DIST_X (0,0,4,4,0,4) = 2	
LINE_DIST_Y	Y coordinates on the line with minimum distance to a point	LINE_DIST (X1,Y1,X2,Y2,X3,Y3) LINE_DIST_Y (0,0,4,4,0,4) = 2	

ANGLE	Incident angle (at point X1, Y1) of line to horizontal axis in the clockwise direction (range +/-180°)	ANGLE (X1,Y1,X2,Y2) ANGLE (0,0,5,5) = 45 ANGLE (5,5,0,0) = -135	
LINE_ANGLE	Incident angle of line to horizontal axis in the clockwise direction (range +/-90°)	LINE_ANGLE (X1,Y1,X2,Y2) LINE_ANGLE (5,5,0,0) = 45	
D_LINE_ANGLE	Acute angle of two intersecting lines	D_LINE_ANGLE (X1,Y1,X2,Y2... D_LINE_ANGLE (0,0,4,4,0,4,0) = 90	
CIRCLE_X	X coordinates of circle formed by three points	CIRCLE_X (X1,Y1,X2,Y2,X3,Y3) CIRCLE_X (-14.6,8.94,-11.64,4.15,-15.61,3.47) = -14	
CIRCLE_Y	Y coordinates of circle formed by three points	CIRCLE_Y (X1,Y1,Y2,Y2,X3,Y3) CIRCLE_Y (-14.6,8.94,-11.64,4.15,-15.61,3.47) = 6	
CIRCLE_R	Radius (R) of circle formed by three points	CIRCLE_R (X1,Y1,X2,Y2,X3,Y3) CIRCLE_R (-14.6,8.94,-11.64,4.15,-15.61,3.47) = 3	

Remark Use a comma to separate the elements. For example: AVG (2,3,4)

■ (Item 5) Upper/lower limit

You can restrict the calculator results by the upper and lower limits to give an OK/NG logic result. The system passes this result to the subsequent [Judge] and [Output] programs.

As shown in the example to the right, the upper and lower limits are 200 and 100. The logic result is OK if calculator result falls in this range; otherwise, the logic result is NG.

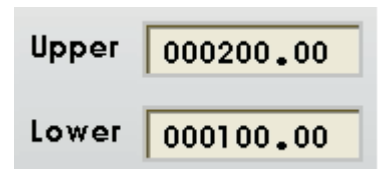

7.2.2 [Calculator] function list

This section describes how you select a function output for a calculation using function codes. Taking the data format (Position - X coordinates) using $W□□□[△△]X$ as an example.

$W□□□$: The number of the inspection window. For example: W005 is the 5th window.

$[△△]$: The number of the result as output. For example, if three positions are detected for W005, $[△△] = 2$ indicates that the second edge result is the output (calculation).

X: X coordinates.

So for this example, the function code is $W005[2]X$. The following table lists the Function codes by function.

Function	Syntax	Description	Measure	Calculator data format
Area	TAR	Total area	--	$W□□□TAR$
Position	N	Quantity	--	$W□□□N$
	X	X coordinates	$[△△]$	$W□□□[△△]X$
	Y	Y coordinates	$[△△]$	$W□□□[△△]Y$
	AG	Absolute Angle (horizontal at 0°) of circle and arc	$[△△]$	$W□□□[△△]AG$
	RA	Relative Angle (to initial angle) of circle and arc	$[△△]$	$W□□□[△△]RA$
Count	N	Number of edges	--	$W□□□N$
Width	L	Width (unit: pixels or degrees)	--	$W□□□L$
	X1	X coordinates of first edge	--	$W□□□X1$
	Y1	Y coordinates of first edge	--	$W□□□Y1$
	AG1	Absolute Angle 1 of circle and arc	--	$W□□□AG1$
	RA1	Relative Angle 1 of circle and arc	--	$W□□□RA1$
	X2	X coordinates of second edge	--	$W□□□X2$
	Y2	Y coordinates of second edge	--	$W□□□Y2$
	AG2	Absolute Angle 2 of circle and arc	--	$W□□□AG2$
	RA2	Relative Angle 2 of circle and arc	--	$W□□□RA2$
Pitch	N	Quantity	--	$W□□□N$
	W	Pitch distance (unit: pixels or degrees)	$[△△]$	$W□□□[△△]W$
	WH	Maximum pitch (unit: pixels or degrees)	--	$W□□□WH$
	WL	Minimum pitch (unit: pixels or degrees)	--	$W□□□WL$
	WA	Average pitch (unit: pixels or degrees)	--	$W□□□WA$
	XS	X coordinates of first edge	$[△△]$	$W□□□[△△]XS$
	YS	Y coordinates of first edge	$[△△]$	$W□□□[△△]YS$
	AGS	Absolute Angle 1 of circle and arc	$[△△]$	$W□□□[△△]AGS$
	RAS	Relative Angle 1 of circle and arc	$[△△]$	$W□□□[△△]RAS$

	XE	X coordinates of second edge	[△△]	W□□□[△△]XE
	YE	Y coordinates of second edge	[△△]	W□□□[△△]YE

	AGE	Absolute Angle 2 of circle and arc	[△△]	W□□□[△△]AGE
	RAE	Relative Angle 2 of circle and arc	[△△]	W□□□[△△]RAE
	X	X coordinates of pitch center	[△△]	W□□□[△△]X
	Y	Y coordinates of pitch center	[△△]	W□□□[△△]Y
	AG	Absolute angle of edge center of circle and arc	[△△]	W□□□[△△]AG
Angle	EAG	Angle (horizontal at 0°)	--	W□□□EAG
	X1	X coordinates of top Angle	--	W□□□X1
	Y1	Y coordinates of top Angle	--	W□□□Y1
	X2	X coordinates of bottom Angle	--	W□□□X2
	Y2	Y coordinates of bottom Angle	--	W□□□Y2
Intensity	IA	Average brightness	--	W□□□IA
	ID	Standard deviation of brightness	--	W□□□ID
	IH	Maximum brightness	--	W□□□IH
	IL	Minimum brightness	--	W□□□IL
Shape	N	Quantity	--	W□□□N
	S	Similarity	[△△]	W□□□S
	X	X coordinates of found object	[△△]	W□□□X
	Y	Y coordinates of found object	[△△]	W□□□Y
	XH	Maximum X coordinates of all objects	--	W□□□XH
	XL	Minimum X coordinates of all objects	--	W□□□XL
	YH	Maximum Y coordinates of all objects	--	W□□□YH
	YL	Minimum Y coordinates of all objects	--	W□□□YL
	AG	Object angle found	[△△]	W□□□AG
Spot	N	Quantity	--	W□□□N
	X	Center X coordinates	[△△]	W□□□[△△]X
	Y	Center Y coordinates	[△△]	W□□□[△△]Y
	XH	Maximum X coordinates of all spot centers	--	W□□□XH
	XL	Minimum X coordinates of all spot centers	--	W□□□XL
	YH	Maximum Y coordinates of all spot centers	--	W□□□YH
	YL	Minimum Y coordinates of all spot centers	--	W□□□YL
	AR	Spot area	[△△]	W□□□[△△]AR
	ARH	Maximum area	--	W□□□ARH
	ARL	Minimum area	--	W□□□ARL
	RD	Roundness	[△△]	W□□□[△△]RD
	RDH	Maximum roundness	--	W□□□RDH
	RDL	Minimum roundness	--	W□□□RDL
	AG	Incident clockwise angle of main axis to horizontal axis	[△△]	W□□□[△△]AG

	AGH	Maximum incident clockwise angle of all main axis to horizontal axis	--	W□□□AGH
	AGL	Minimum incident clockwise angle of all main axis to horizontal axis	--	W□□□AGL
	PE	Circumference	[△△]	W□□□[△△]PE
	PEH	Maximum circumference	--	W□□□PEH
	PEL	Minimum circumference	--	W□□□PEL
	EX	Extension length in X (horizontal) direction	[△△]	W□□□[△△]EX
	EY	Extension length in Y (vertical) direction	[△△]	W□□□[△△]EY
	EXH	Maximum extension length in X (horizontal) direction	--	W□□□EXH
	EXL	Minimum extension length in X (horizontal) direction	--	W□□□EXL
	EYH	Maximum extension length in Y (horizontal) direction	--	W□□□EYH
	EYL	Minimum extension length in Y (horizontal) direction	--	W□□□EYL
	TLX	Top-left X coordinates of extension rectangle	[△△]	W□□□[△△]TLX
	TLY	Top-left Y coordinates of extension rectangle	[△△]	W□□□[△△]TLY
	MA	Main axis length	[△△]	W□□□[△△]MA
	MAH	Maximum length from all main axis	--	W□□□MAH
	MAL	Minimum length from all main axis	--	W□□□MAL
Stain (defect)	TAR	Total defective area	--	W□□□TAR
	N	Cluster	--	W□□□N
	AR	Defective area	[△△]	W□□□[△△]AR
	ARH	Maximum defective area	--	W□□□ARH
	ARL	Minimum defective area	--	W□□□ARL
	X	Center X coordinates of all defects	[△△]	W□□□[△△]X
	Y	Center Y coordinates of all defects	[△△]	W□□□[△△]Y
	XH	Maximum X coordinates of all defect centers	--	W□□□XH
	XL	Minimum X coordinates of all defect centers	--	W□□□XL
	YH	Maximum Y coordinates of all defect centers	--	W□□□YH
	YL	Minimum Y coordinates of all defect centers	--	W□□□YL
Position Trace	N	Total	--	W□□□N
	X	X coordinates of all edges	[△△]	W□□□[△△]X
	Y	Y coordinates of all edges	[△△]	W□□□[△△]Y
	XH	X coordinates of maximum outline	--	W□□□XH

	XL	X coordinates of minimum outline	--	W□□□XL
	YH	Y coordinates of maximum outline	--	W□□□YH
	YL	Y coordinates of minimum outline	--	W□□□YL
	XA	Average X coordinates of all outlines	--	W□□□XA
	YA	Average Y coordinates of all outlines	--	W□□□YA
	D	Distances of all outlines	[△△]	W□□□[△△]D

	DH	Maximum distance of all outlines	--	W□□□DH
	DL	Minimum distance of all outlines	--	W□□□DL
	DA	Average distance of all outlines	--	W□□□DA
	RD	Roundness	--	W□□□RD
	CX	Center X coordinates of circle	--	W□□□CX
	CY	Center Y coordinates of circle	--	W□□□CY
	CRU	Circle radius	--	W□□□CRU
Width tracking	N	Total	--	W□□□N
	WH	Maximum Width	--	W□□□WH
	WL	Minimum Width	--	W□□□WL
	WA	Average Width	--	W□□□WA
	W	All Widths	[△△]	W□□□[△△]W
	HX1	X1 coordinates of maximum width	--	W□□□HX1
	HY1	Y1 coordinates of maximum width	--	W□□□HY1
	HX2	X2 coordinates of maximum width	--	W□□□HX2
	HY2	Y2 coordinates of maximum width	--	W□□□HY2
	LX1	X1 coordinates of minimum width	--	W□□□LX1
	LY1	Y1 coordinates of minimum width	--	W□□□LY1
	LX2	X2 coordinates of minimum width	--	W□□□LX2
	LY2	Y2 coordinates of minimum width	--	W□□□LY2
	XS	X1 coordinates of width across all edges	[△△]	W□□□[△△]XS
	YS	Y1 coordinates of width across all edges	[△△]	W□□□[△△]YS
	XE	X2 coordinates of width across all edges	[△△]	W□□□[△△]XE
	YE	Y2 coordinates of width across all edges	[△△]	W□□□[△△]YE
	RD1	Roundness 1 (inner)	--	W□□□RD1
	CX1	X coordinates of circle 1 center	--	W□□□CX1
	CY1	Y coordinates of circle 1 center	--	W□□□CY1
CR1	Circle 1 radius	--	W□□□CR1	
RD2	Roundness 2 (outer)	--	W□□□RD2	
CX2	Center X coordinates of circle 2	--	W□□□CX2	
CY2	Center Y coordinates of circle 2	--	W□□□CY2	
CR2	Circle 2 radius	--	W□□□CR2	
Character Recognition	N	Total Number of Characters	--	W□□□N
	R1N	Number of Characters in Row1	--	W□□□R1N
	R2N	Number of Characters in Row2	--	W□□□R2N
	X1S	Starting X coordinate of the designated character found from the string in the first row	[△△]	W□□□[△△]X1S
	X1E	Ending X coordinate of the designated	[△△]	W□□□[△△]X1E

		character found from the string in the first row		
Y1S		Starting Y coordinate of the designated character found from the string in the first row	[△△]	W□□□[△△]Y1S
Y1E		Ending Y coordinate of the designated character found from the string in the first row	[△△]	W□□□[△△]Y1E
C1		Outputs the result of the designated character found from the string in the first row	[△△]	W□□□[△△]C1
S1		The degree of similarity of the designated character found from the string in the first row	[△△]	W□□□[△△]S1
X2S		Starting X coordinate of the designated character found from the string in the second row	[△△]	W□□□[△△]X2S
X2E		Ending X coordinate of the designated character found from the string in the second row	[△△]	W□□□[△△]X2E
Y2S		Starting Y coordinate of the designated character found from the string in the second row	[△△]	W□□□[△△]Y2S
Y2E		Ending Y coordinate of the designated character found from the string in the second row	[△△]	W□□□[△△]Y2E
C2		Outputs the result of the designated character found from the string in the second row	[△△]	W□□□[△△]C2
S2		The degree of similarity of the designated character found from the string in the second row	[△△]	W□□□[△△]S2
X1H		The largest X coordinate in all characters found from the string in the first row	--	W□□□X1H
X1L		The smallest X coordinate in all characters found from the string in the first row	--	W□□□X1L
Y1H		The largest Y coordinate in all characters found from the string in the first row	--	W□□□Y1H
Y1L		The smallest Y coordinate in all characters found from the string in the first row	--	W□□□Y1L

	X2H	The largest X coordinate in all characters found from the string in the second row	--	W□□□X2H
	X2L	The smallest X coordinate in all characters found from the string in the second row	--	W□□□X2L
	Y2H	The largest Y coordinate in all characters found from the string in the second row	--	W□□□Y2H
	Y2L	The smallest Y coordinate in all characters found from the string in the second row	--	W□□□Y2L
	S1H	The highest degree of character similarity among all characters found from the string in the first row	--	W□□□S1H
	S1L	The lowest degree of character similarity among all characters found from the string in the first row	--	W□□□S1L
	S2H	The highest degree of character similarity among all characters found from the string in the second row	--	W□□□S2H
	S2L	The lowest degree of character similarity among all characters found from the string in the second row	--	W□□□S2L
Classification	N	Number of objects	--	W□□□N
	CID	Object ID (According to the window ID of the pattern for classification)	[△△]	W□□□[△△]CID
	X	X coordinate of object	[△△]	W□□□[△△]X
	Y	Y coordinate of object	[△△]	W□□□[△△]Y
	AG	Object angle	[△△]	W□□□[△△]AG
	S	Object score	[△△]	W□□□[△△]S
	XH	Largest X coordinate of all objects	--	W□□□XH
	XL	Smallest X coordinate of all objects	--	W□□□XL
	YH	Largest Y coordinate of all objects	--	W□□□YH
	YL	Smallest Y coordinate of all objects	--	W□□□YL
	COX	Determine X coordinate of object using registered image	--	W□□□COX
	COY	Determine Y coordinate of object using registered image	--	W□□□COY
COA	Determine object angle using registered image	--	W□□□COA	
Barcode Recognition	L	Number of characters and numbers	--	W□□□L
	C	Barcode type	--	W□□□C

	STR	Character and number	[△△]	W□□□STR
Mark	MKX	Mark X coordinate	[△△]	W□□□[△△]MKX
	MKY	Mark Y coordinate	[△△]	W□□□[△△]MKY

7.3 What is [Judge]?

The final output is usually determined by the results of multiple inspections, where the system processes the judgment logic OK(1) or NG(0) to generate a composite result.

For example, using the AND command on three OK results to generate the OK result indicates that all three inspection items must be OK. At this time, the ANDs in the Judge can operate these three results. Similarly, using the OR command to three OK flags to generate the OK result indicates that at least one inspection item must be OK.

Each individual project supports up to 32 judgments (J00–J31) and the system can pass each judgment ID to the subsequent [Output] program.

7.4 Edit [Judge]

7.4.1 [Judge] interface

- From [Program], select the [Judge] editing menu.

Item	Description
1	Judgment display
2	Select [View] judgment value list
3	Built-in functions

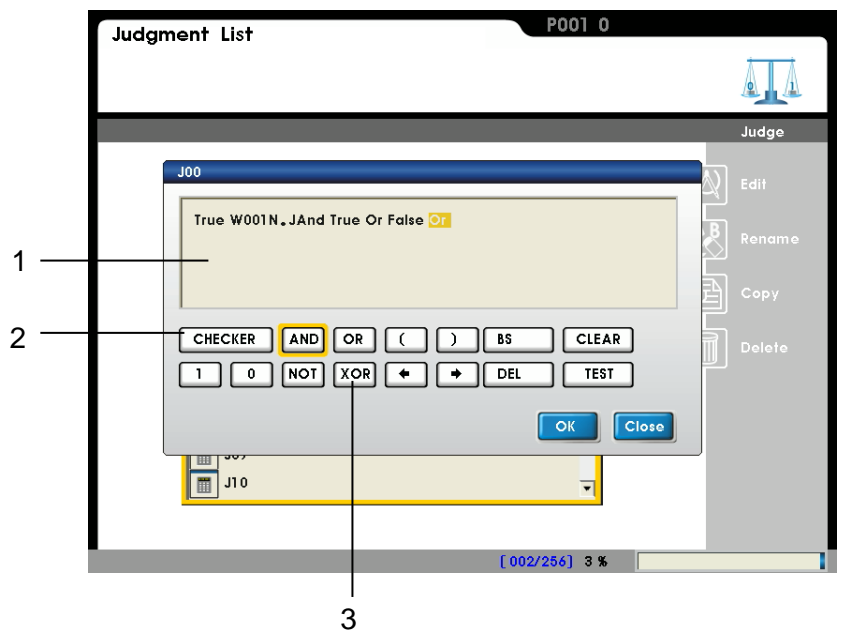

(Item 1) Judgment display

Depending on the function, you can enter approximately 15 entries in the display area.

If you exceed the judgment space, you can carry over the result to the next judgment ID for more calculations.

The picture to the right shows exceeding the judgment space for J00 and so the J00 logic flag OK(1)/NG(0) is called by J01 for further extension (J00V).

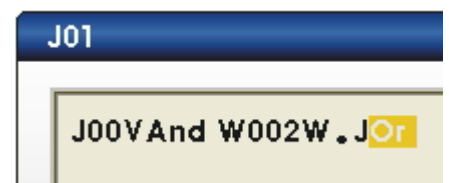

■ (Item 2) Select [View] judgment value list

Press the **CHECKER** button to select the available results from the existing [Window]. Select the Window, and then select the function output from the Window (represented by function codes).

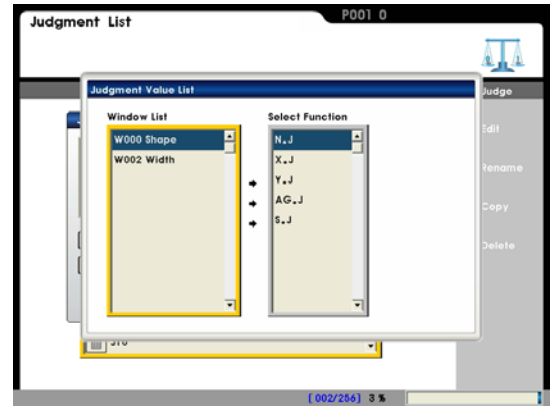

Reference Refer to Section 7.4.2 for the list of [Judge] [Function] codes.

■ (Item 3) Built-in functions

Additional keys

Control unit	Description
BS	Use Backspace to delete the previous field.
DEL	Use Delete to delete the current field.
CLEAR	Use Clear to delete all calculator fields (with a confirmation popup window).
TEST	Get results to test current settings.

Function unit

Function	Description	Example	Note:
0	Logical False (NG)		
1	Logical True (OK)		
AND	AND gate	False AND True = 0	Output 1 if all inputs are 1.
OR	OR gate	False OR True = 1	Output 1 if any input is 1.
NOT	INV gate	NOT (False) = 1	Output 1 if input is 0; output 0 if input is 1.
XOR	XOR gate	False XOR False = 0 True XOR True = 0 False XOR True = 1 True XOR False = 1	Output 0 if inputs match; output 1 if inputs differ.

7.4.2 [Judge] function list

This section describes how you select a function output for a calculation using function codes. Taking the data format (Position - X coordinates) using W□□□X.J as an example.

W□□□: The number of the inspection window. For example: W005 is the 5th window.

X.J: X coordinates of the judgment result.

So for this example, the function code is W005X.J The following lists the Function codes by function.

Remark .J is the logic result filtered from the [Limit] parameter for a function.

Function	Syntax	Description	Judge Data format
Area	TAR.J	Total area	W□□□TAR.J
Position	X.J	X coordinates	W□□□X.J
	Y.J	Y coordinates	W□□□Y.J
	AG.J	Absolute Angle (horizontal at 0°) of circle and arc	W□□□AG.J
Count	N.J	Number of edges	W□□□N.J
Width	W.J	Width (unit: pixels or degrees)	W□□□W.J
	X.J	X coordinates of first edge	W□□□X.J
	Y.J	Y coordinates of first edge	W□□□Y.J
	AG.J	Absolute Angle 1 of circle and arc	W□□□AG.J
Pitch	N.J	Quantity	W□□□N.J
	W.J	Pitch distance (unit: pixels or degrees)	W□□□W.J
	WH.J	Maximum pitch (unit: pixels or degrees)	W□□□WH.J
	WL.J	Minimum pitch (unit: pixels or degrees)	W□□□WL.J
	WA.J	Average pitch (unit: pixels or degrees)	W□□□WA.J
Angle	AG.J	Angle (horizontal at 0°)	W□□□AG.J
Intensity	IA.J	Average brightness	W□□□IA.J
	ID.J	Standard deviation of brightness	W□□□ID.J
	IH.J	Maximum brightness	W□□□IH.J
	IL.J	Minimum brightness	W□□□IL.J
Shape	N.J	Quantity	W□□□N.J
	X.J	X coordinates of found object	W□□□X.J
	Y.J	Y coordinates of found object	W□□□Y.J
	AG.J	Object angle found	W□□□AG.J
	S.J	Similarity	W□□□S.J
Spot	N.J	Quantity	W□□□N.J
	X.J	Center X coordinates	W□□□X.J
	Y.J	Center Y coordinates	W□□□Y.J
	AR.J	Spot area	W□□□AR.J
	PE.J	Circumference	W□□□PE.J

Stain (defect)	N.J	Cluster	W□□□N.J
	TAR.J	Total defective area	W□□□TAR.J
	AR.J	Defective area	W□□□AR.J
	X.J	Center X coordinates of all defects	W□□□X.J
	Y.J	Center Y coordinates of all defects	W□□□Y.J
Position Trace	XH.J	X coordinates of maximum outline	W□□□XH.J
	YH.J	Y coordinates of maximum outline	W□□□YH.J
	XL.J	X coordinates of minimum outline	W□□□XL.J
	YL.J	Y coordinates of minimum outline	W□□□YL.J
	RD.J	Roundness	W□□□RD.J
Width tracking	WH.J	Maximum Width	W□□□WH.J
	WL.J	Minimum Width	W□□□WL.J
	WA.J	Average Width	W□□□WA.J
	RD1.J	Roundness 1 (inner)	W□□□RD1.J
	RD2.J	Roundness 2 (outer)	W□□□RD2.J
Character Recognition	R1S.J	Row1 Character Score Judge Result	W□□□R1S.J
	R2S.J	Row2 Character Score Judge Result	W□□□R2S.J
	R1.J	Row1 Character Judge Result	W□□□R1.J
	R2.J	Row2 Character Judge Result	W□□□R2.J
Classification	N.J	Number of objects Judge Result	W□□□N.J
	X.J	Object X coordinate Judge Result	W□□□X.J
	Y.J	Object Y coordinate Judge Result	W□□□Y.J
	AG.J	Object angle Judge Result	W□□□AG.J
	S.J	Object score Judge Result	W□□□S.J
Barcode Recognition	L.J	Number of characters and numbers Judge Result	W□□□L.J
	STR.J	Judge Result	W□□□STR.J

7.5 What is [Output]?

You can output each inspection result (value and logic from Window, Calculator, and Judge) to the PC or PLC. The DMV1000 controller supports the following hardware interfaces: Parallel, RS232, Ethernet, USB, and SD card. You can customize the hardware combination to your requirements.

You can independently select the output interface and data. For example, when you enable RS232 to PLC, and Ethernet to PC at the same time, the system outputs three data sets for RS232 and ten data sets for Ethernet. The system initiates data output for these two interfaces simultaneously after the inspection is complete.

7.6 Edit [Output]

7.6.1 Setup [Output]

The output interfaces [Parallel], [RS232], [Ethernet], and [SD card] are identically configured as shown below.

- Select an output interface as shown to the right.
- ✧ **Add Checker:** Select Window parameter to output.
- ✧ **Add Judge:** Select Judge item (OK/NG) to output.
- ✧ **Delete:** Delete selected parameter or judgment output.
- ✧ **Up/Down:** The output string begins from the first entry. Use Up and Down to change to move the selected output.

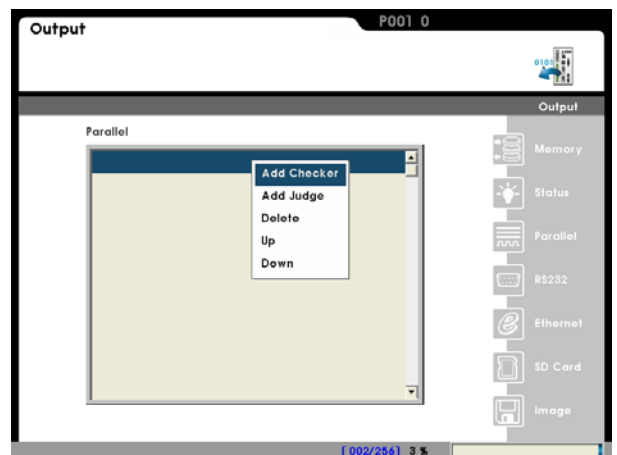

- [Add Checker]

All Windows outputs appear on the screen after you add the parameters. Select the output item from the list. For example: As shown to the right, select W001 Position and then select N to output the number of positions detected by the W001 Position function.

Reference Refer to Section 7.2.2 for the list of Calculator [Function] codes.

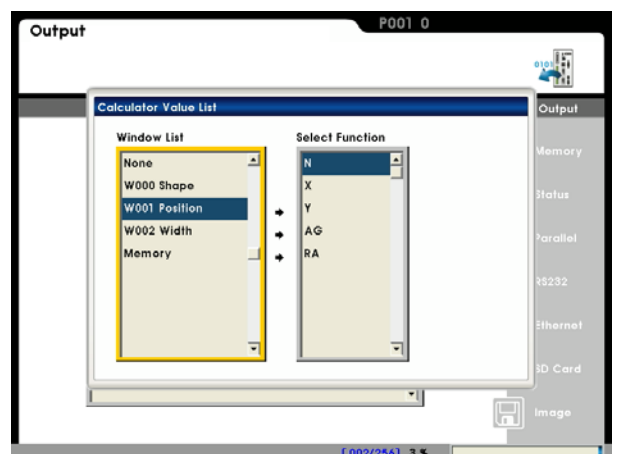

■ [Add Judge]

A 16-bit register can store up to 16 OK/NG judgments. You can add the bits out of order, as shown to the right, with 3 bits of [bit 15], [bit 14], and [bit 12].

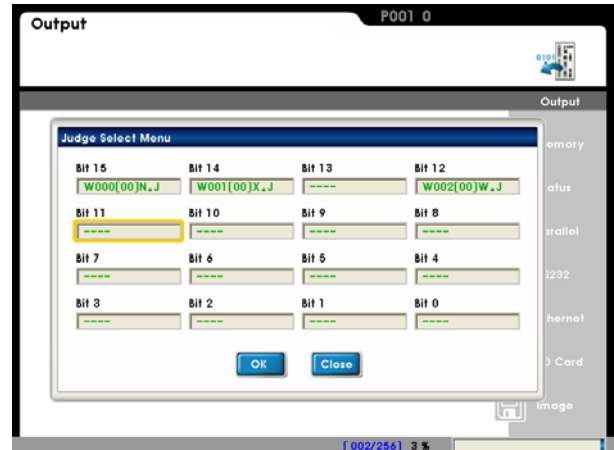

All configured bits appear on the screen after you select them. Select the output judgment from the list. For example: As shown to the right, select the W001 Position and then select X.J to output the judgment result at the X coordinates detected by the W001 Position function.

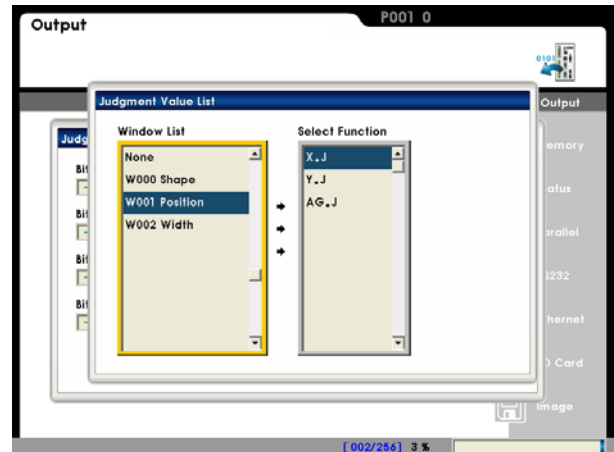

Reference Refer to Section 7.4.2 for the list of Judge [Function] codes.

■ [Up/Down]

Data output begins from the top entry, and you can alter the output sequence using the [Up] and [Down] keys.

As shown to the right, W002N (qty), W003L (width), and JUDGE(...) are output in sequence.

You can also modify JUDGE(...) by selecting it and then selecting the [Modify] option.

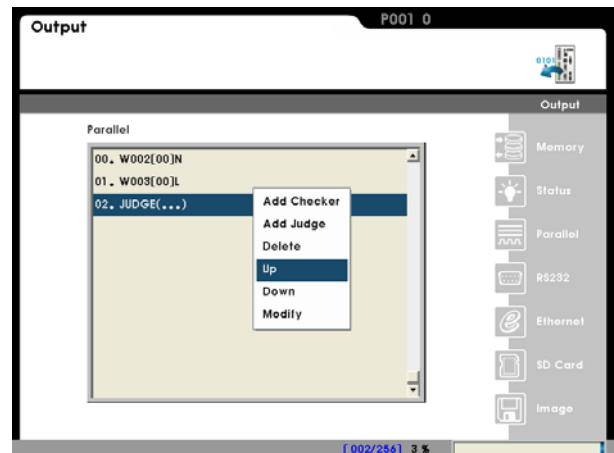

■ [Setup]

You can configure the RS232 output interface with the [Setup] option to use RS232, Modbus, and PLC LINK modes.

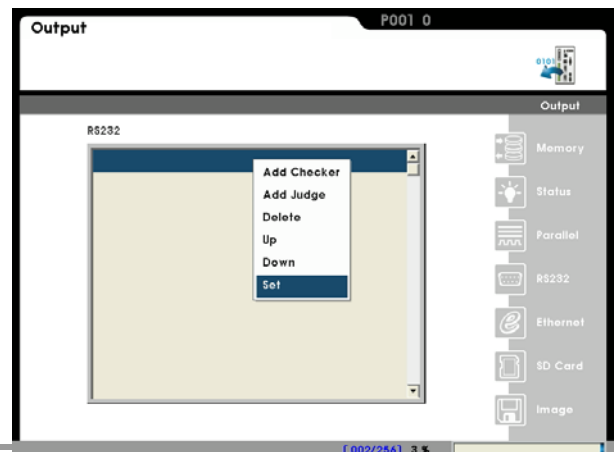



Reference

Refer to Sections 9.2 and 9.3

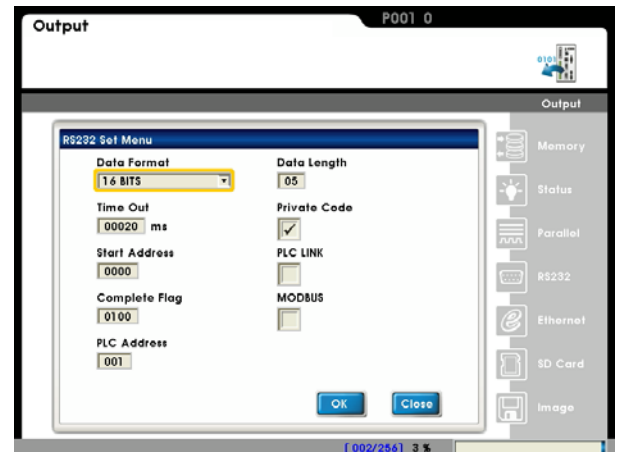

7.6.2 Setup [Image output]

You can save the inspection image for further analysis if a program (or comprehensive output) results in NG.

■ Select camera

Save the image from [Camera 1], [Camera 2], or [All cameras] in the event of a NG result.

■ Title

Saved image filename. For example in the picture to the right, the filename format is saved as [Title] = ABC
 “ABC20110801_121036_000000001_NG_1.BMP”

- ◇ 20110801: Date
- ◇ 121036: Time
- ◇ 000000001: Sequence number
- ◇ NG: Save when NG
- ◇ 1: Camera 1 image

■ Output Interface Select

Output the image to [Ethernet], [USB], or [SD card].

■ Output Trigger Select

Select the source trigger for saving the image. For example: W000TAR.J indicates if the W000 (Area) function result is NG, then save the image.

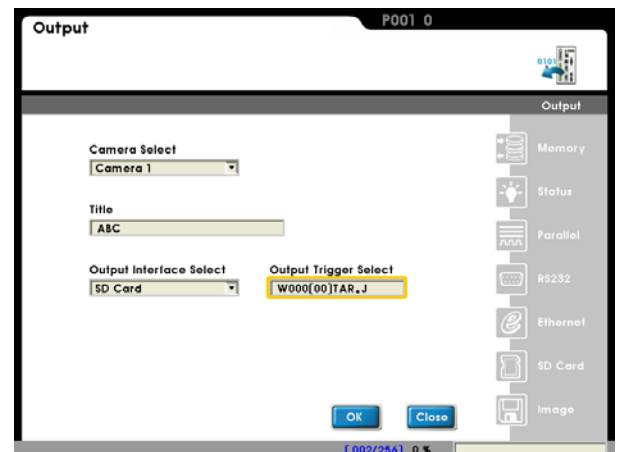

7.6.3 Setup [Status]

You can customize the status indicators on the execution screen to monitor the OK/NG results. The status indicator screen includes the [OK/NG] and [Field 01–24] settings.

■ OK/NG

The execution screen displays the OK/NG icon in the top-right corner. As shown to the right, W000TAR.J indicates that the [Area] result is displayed on the execution screen.

■ Field 01–24

The execution screen displays the custom OK/NG icon at the bottom. As shown to the right, 24 custom definitions are available.

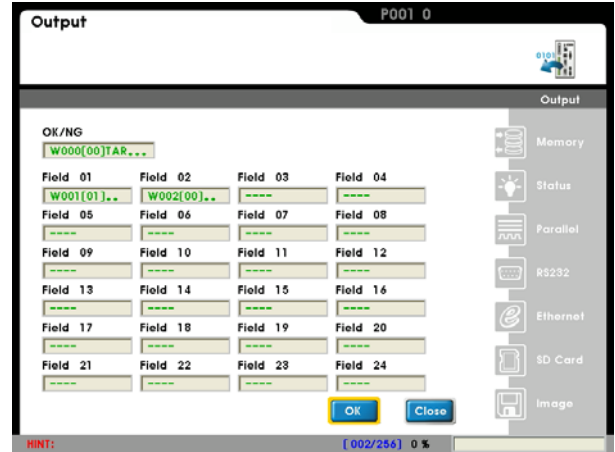

Remark

After setting up the output, the TOUT terminal outputs the ON/OFF state of [OK/NG]. Use the `left` / `right` keys to access [Field 01–24] on the execution screen.

Chapter 8

I/O Timing

The I/O interface is the main communication channel to the controller, and has the functions listed below.

- **Current system state indicator**
For example: Ready and Error.
- **Camera imaging trigger capture**
You can also issue this trigger action through the RS232 or Ethernet ports; however, the I/O channel is more responsive than the communication channels.
- **Flash output**
The system parameters control the flash output with the camera shutter action; use with the light controller.
- **Project switching**
There are multiple I/O signals to switch projects. You can also issue this trigger action through the RS232 or Ethernet ports.
- **Output results**
After each inspection, the system can submit the results OK = 1 or NG = 0 through the I/O channel. The system can also transmit these values through the RS232 or Ethernet ports. In general, if the output consists of only OK = 1 and NG = 0 data, the I/O channel is more responsive and the string does not need to be processed.

8.1 I/O Timing

8.1.1 TRIG (Trigger capture)

- One camera coupled with one TRIG signal

Select either Camera1 or Camera2 (Camera1 is limited to TRIG1, Camera2 is limited to TRIG2).

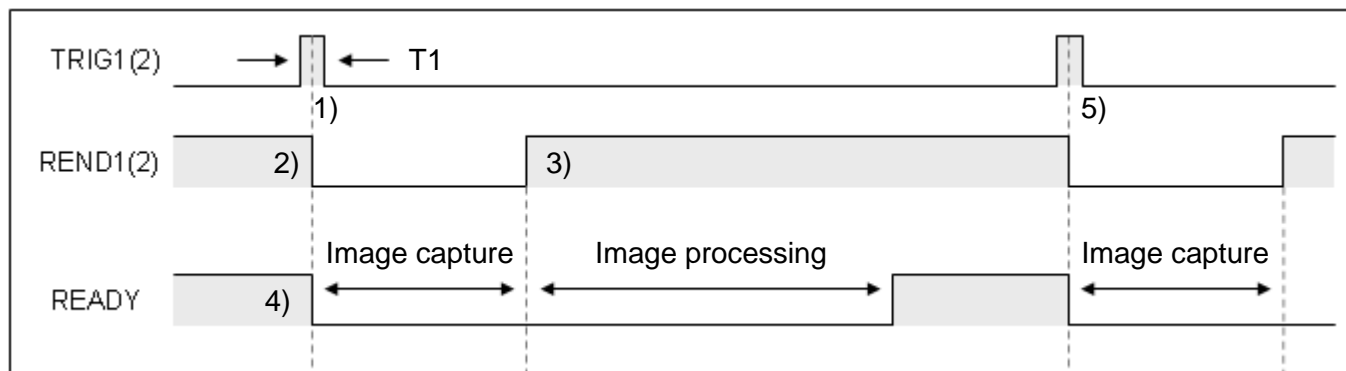

Description:

- 1) Trigger period T1 must be longer than 1 ms. If T1 is too short, the system may ignore the trigger.
- 2) REND is OFF after triggering.
- 3) When the image is captured (exposure + transfer), REND signal is ON.
- 4) READY is OFF after triggering. READY is ON after inspection is complete (capture + processing).
- 5) Steps 1–4 complete an inspection cycle and the system is ready for the next trigger signal.

TRIG timing depends on the READY signal.

Total period = image capture time + processing time

■ Two cameras coupled with two TRIG signals

Camera1 works with TRIG1, Camera2 works with TRIG2; TRIG1 and TRIG2 can be triggered in either order.

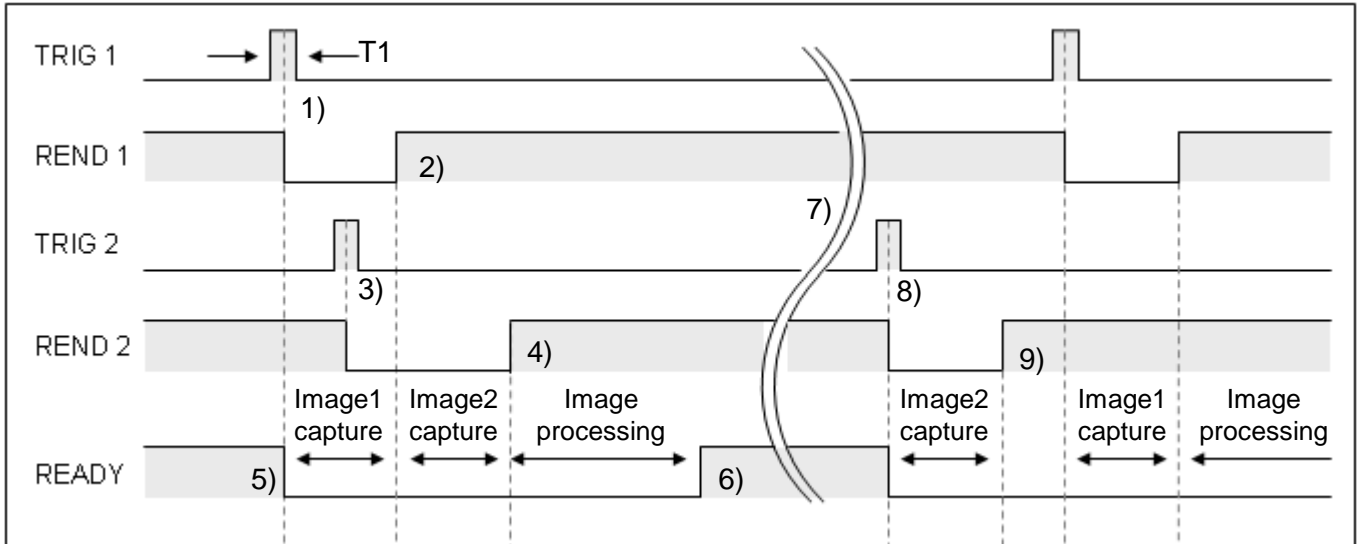

Description:

- 1) Trigger period T1 must be longer than 1 ms. If T1 is too short, the trigger may be ignored.
- 2) When image1 is captured (exposure + transfer), REND1 signal is ON.
- 3) If TRIG2 is triggered during the image1 capture cycle, image2 capture begins after image1 capture cycle is completed.
- 4) When image2 is captured (exposure + transfer), REND2 signal is ON.
- 5) READY signal is OFF if TRIG is triggered.
- 6) READY signal switches ON after image processing is completed.
- 7) Steps 1–6 complete an inspection cycle and the system is ready for the next trigger signal.
- 8) TRIG2 can lead or follow TRIG1.
- 9) In this mode, capture cycles of both TRIG signals must finish before image processing can begin. Therefore, the controller must stay in the trigger standby state before the second TRIG is initialized.

TRIG1 and TRIG2 timings depend on the READY signal.

Total work cycle = first image capture time + second capture time + processing time

- Two cameras coupled with one TRIG signal, when both Camera1 and Camera2 are triggered by TRIG1

TRIG1 triggers the system to automatically capture image1 and image2.

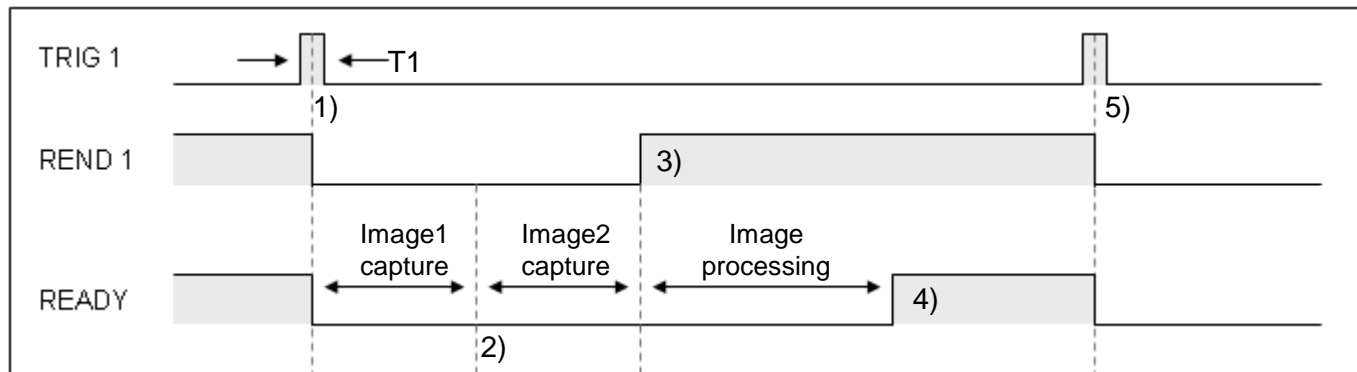

Description:

- 1) Trigger period T1 must be longer than 1 ms. If T1 is too short, the trigger may be ignored.
- 2) Image1 captured, continue with image 2 capture.
- 3) REND1 is ON after image1 and image2 are captured.
- 4) READY is ON after image processing is complete.
- 5) Steps 1–4 complete an inspection cycle and the system is ready for the next trigger signal.

TRIG1 timing depends on the READY signal.

Total cycle time = image1 capture time + image2 capture time + image processing time

8.1.2 Double buffering TRIG (Trigger) capture

The controller features a buffer register that saves the next captured image while the current one is being processed. This means that the image capture and processing functions run simultaneously to reduce total cycle time.

You can use double buffering when the image is captured. The image being inspected can be moved without waiting for the result output. The overall inspection cycle time can be reduced. For example: Camera capture time is 66 ms and image processing takes 200 ms.

Traditional method

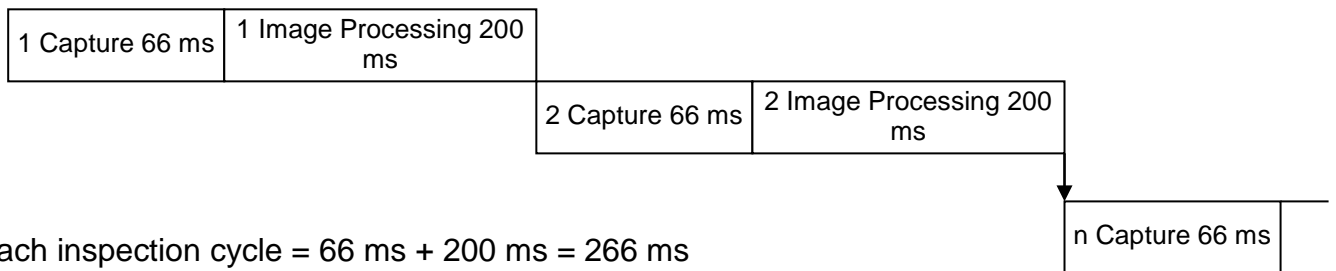

Double buffering

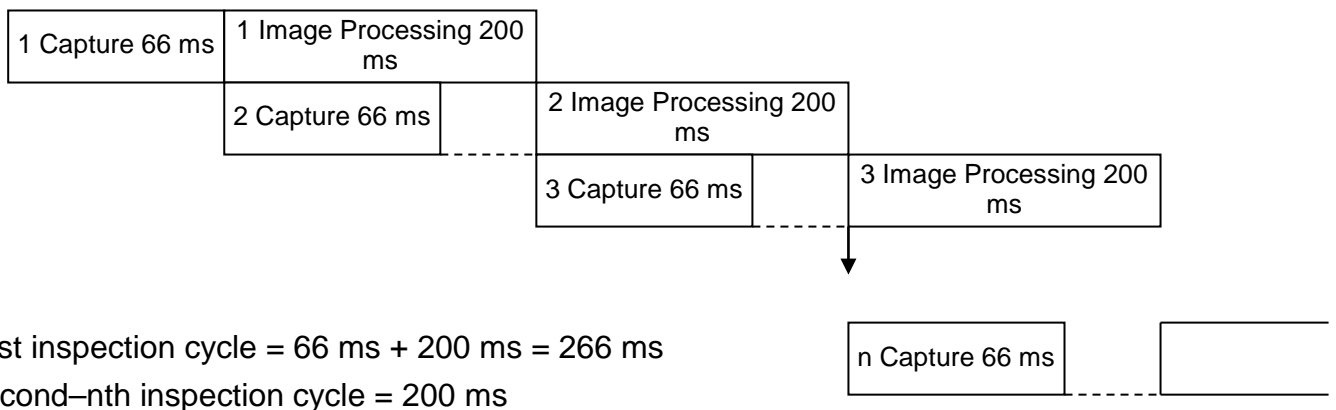

■ Buffer trigger: One camera coupled with one TRIG signal

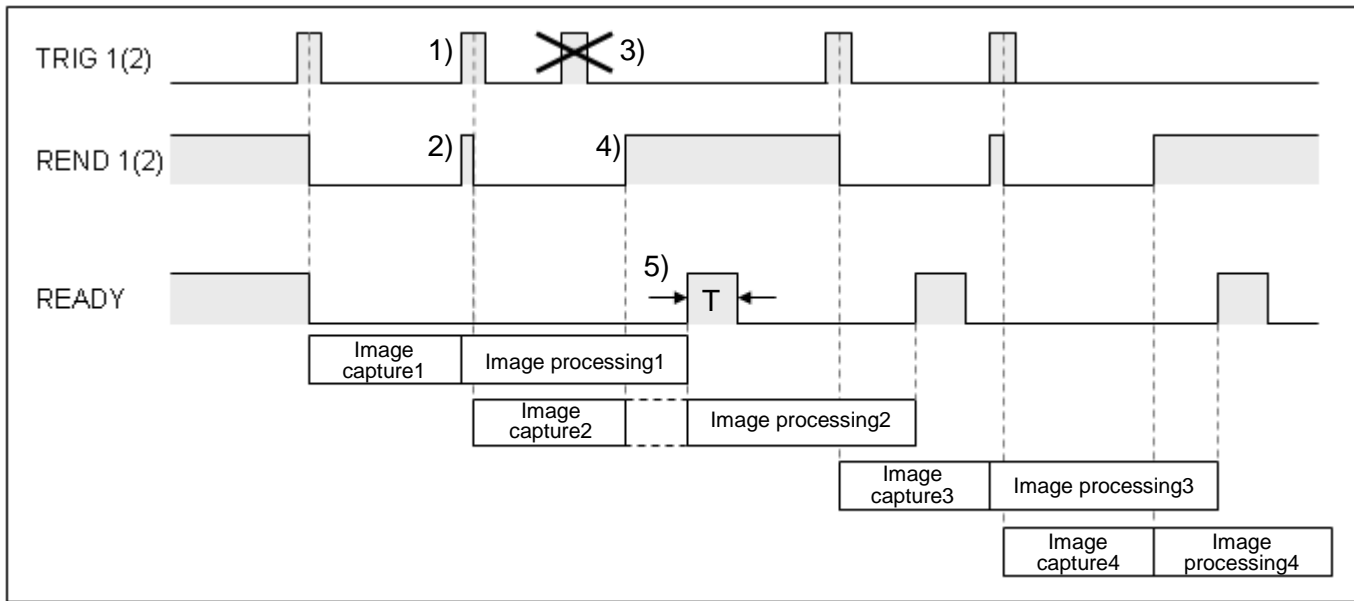

Description:

- 1) Image capture 2 is buffered at the same time as image processing begins.
- 2) Buffering is determined by the REND signal(enabled when REND is ON).
- 3) When REND is OFF, TRIG is ignored.
- 4) When image capture 2 completes, REND is ON to wait for the next trigger.
- 5) Image is being buffered and processing ends. Output READY signal for T period. Default T is 10 ms and can be changed.

TRIG1 and TRIG2 timings depend on the REND1 and REND2 signals.

The system can use the READY signal as the flag to output data. When READY is ON, the output results are ready to be received.

Total cycle time

First = image capture 1 + image processing 1 (READY OFF to READY ON)

Buffered process = rising-edge of T to next rising-edge of T

Intermittent buffered processing

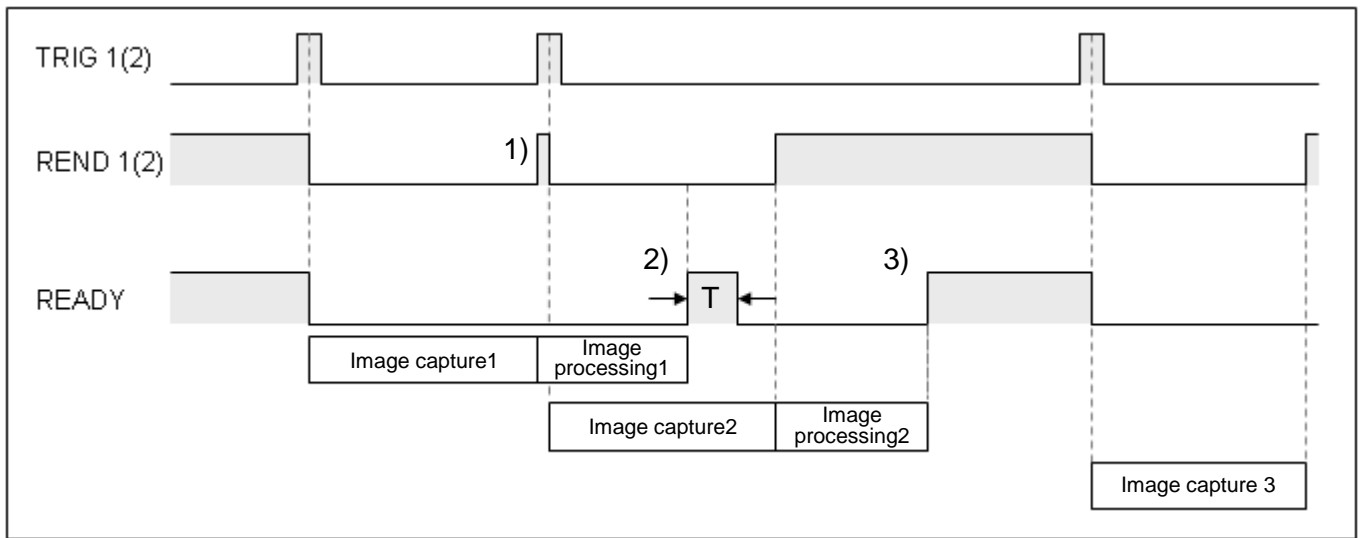

Description:

- 1) Image capture 1 completes, buffer capture 2 initiates.
- 2) Buffer capture occurs during image processing 1, READY output is ON for T period after image processing ends. Default T is 10 ms and can be changed.
- 3) No buffering occurs during image processing 2, READY output follows normal logic when image processing ends. READY is always ON until the next TRIG signal is triggered.

■ Double buffer trigger: Two cameras coupled with two TRIG signals

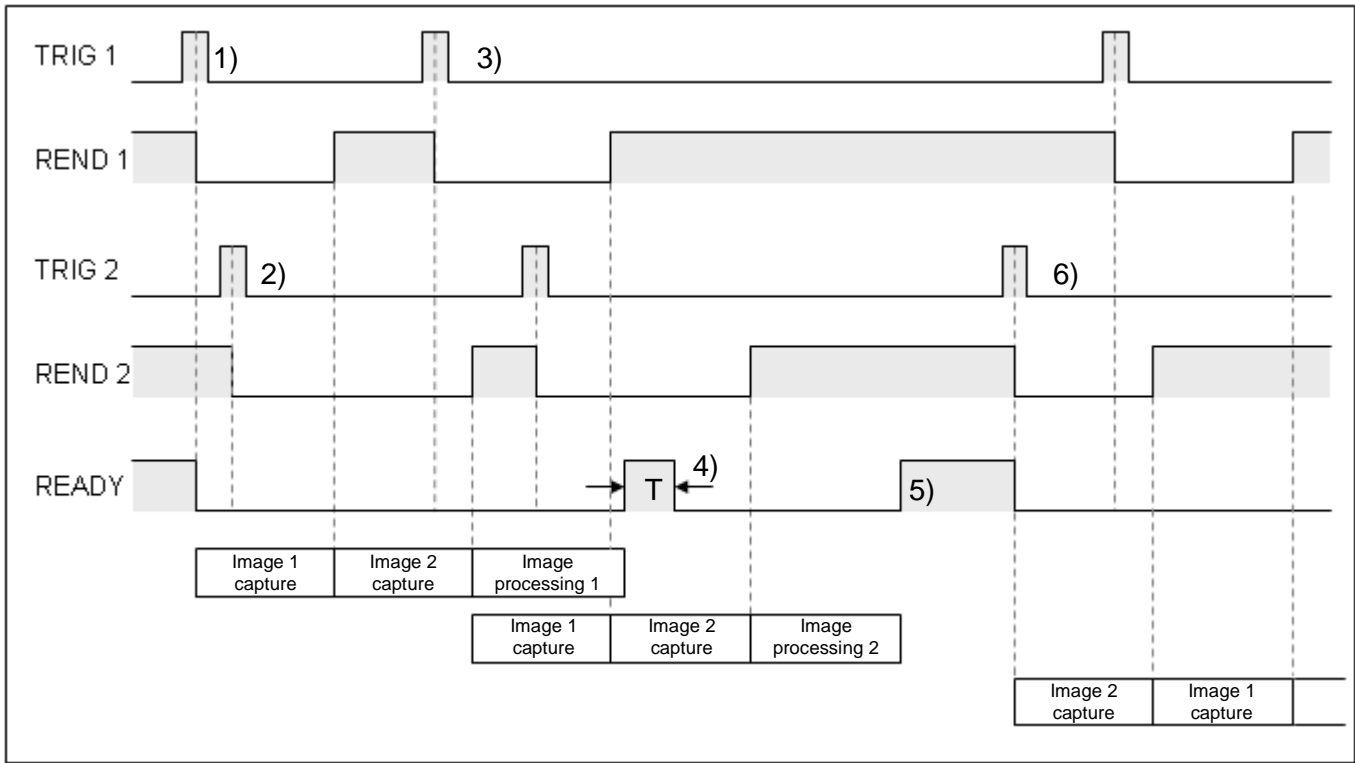

Description:

- 1) TRIG1 is triggered to begin capturing image1.
- 2) TRIG2 is triggered to begin capturing image2, but this image2 capture action is delayed because image1 capture is not yet complete.
- 3) Image1 captured to trigger TRIG1 for double buffering.
- 4) Double buffering occurs during image processing 1. READY output is ON for T period after image processing ends. Default T is 10 ms and can be changed.
- 5) No buffering occurs during image processing 2. READY output follows normal logic when image processing ends. READY is always ON until the next TRIG signal is triggered.
- 6) Image capture 2 can lead or follow image capture 1.

Remark

Image1 is captured by Camera1, and image2 is captured by Camera2

- Double buffer trigger: Two cameras coupled with one TRIG signal, and both Camera1 and Camera2 are triggered by TRIG1.

TRIG1 initiates the system to automatically capture image1 and image2.

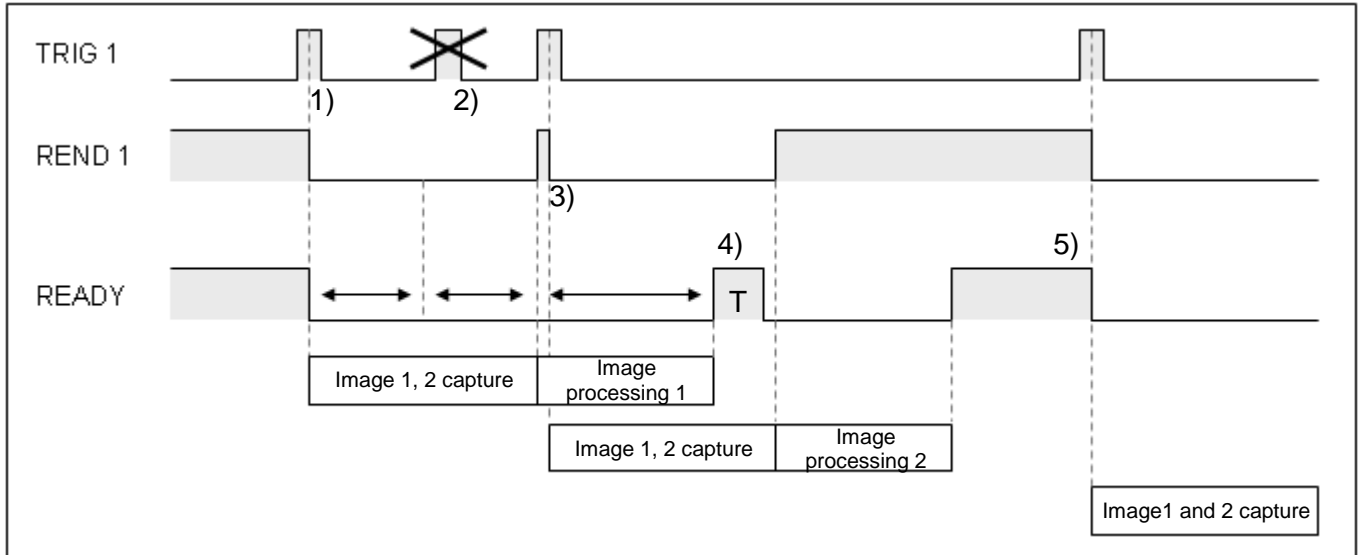

Description:

- 1) TRIG1 is triggered to begin capturing image1 and image2.
- 2) While capturing an image, TRIG1 is ignored.
- 3) After capturing image 1 and image 2, REND1 is ON to receive TRIG1 input.
- 4) Double buffering occurs during image processing 1. READY output is ON for T period after image processing ends. Default T is 10 ms and can be changed.
- 5) No buffering occurs during image processing 2. READY output follows normal logic when image processing ends. READY is always ON until the next TRIG signal is triggered.

8.1.3 FLASH timer output

Proper timing of the light source is crucial to the quality of the image taken. The system supports FLASH1 and FLASH2 outputs to control the peripheral light sources.

Remark The light controller for the light source must have an external trigger input when using the FLASH signal.

- FLASH signal output is enabled before the CCD shutter is activated.

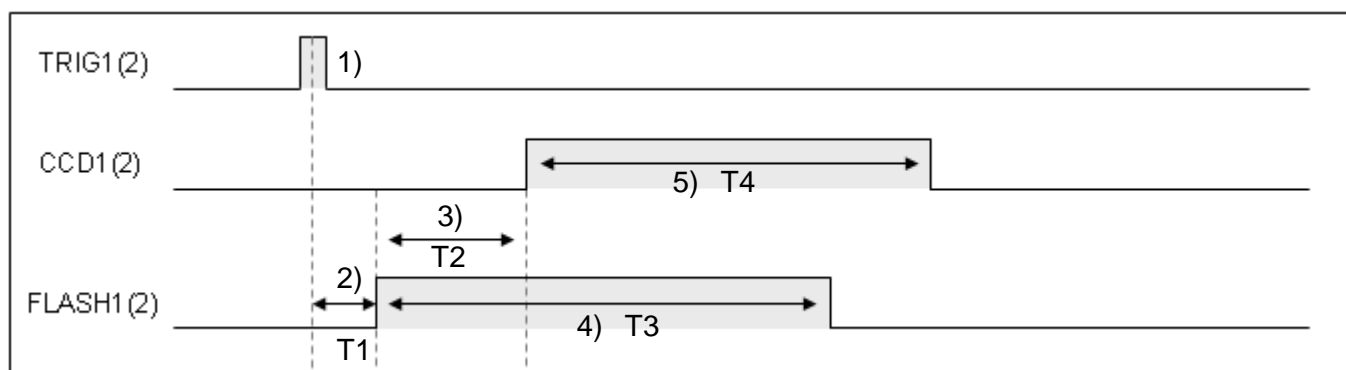

T1: Approximate delay

T2: Setup "Flash action time" (unit: us)

T3: Setup "Flash duration" (unit: 100 us)

T4: Setup "Shutter setting"

Description:

- When TRIG is triggered, timed FLASH output is enabled.
- System delay is handled internally and FLASH output is delayed.
- CCD shutter is delayed because FLASH output takes place before the CCD shutter is activated.
- Total FLASH output duration.
- Camera shutter duration.

Remark Because the CCD1 (2) signal is controlled internally in the system, no external signal pins are provided.

- FLASH signal output is enabled after the CCD shutter.

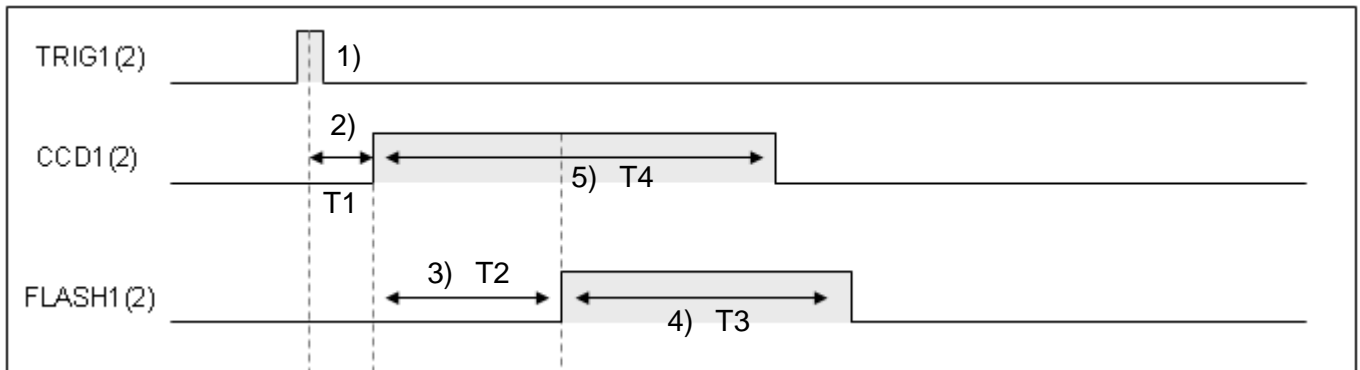

T1: Approximate delay

T2: Setup "Flash action time" (unit: us)

T3: Setup "Flash duration" (unit: 100 us)

T4: Setup "Shutter setting"

Description:

- 1) When TRIG is triggered, timed FLASH output is enabled.
- 2) System delay is handled internally and the CCD is delayed after the shutter capture.
- 3) The FLASH output is delayed because FLASH output comes after CCD shutter activation.
- 4) Total FLASH output duration.
- 5) Camera shutter duration.

If the flash duration is greater than [shutter duration + frame refresh time + internal processing time], the flash will always remain ON.

If the "shutter duration" and "flash turn on time" are in sync and short in length, the flash is constantly turning on and is almost always ON.

8.1.4 Output result

The DMV1000 supports parallel I/O, RS232, USB, Ethernet, PLC, and memory card output methods. Communication can be a combination of the different channels based on the controller hardware or speed requirement.

■ Parallel I/O: (no handshaking)

In addition to the total output (TOUT), there are 16 outputs for status indicators or value outputs.

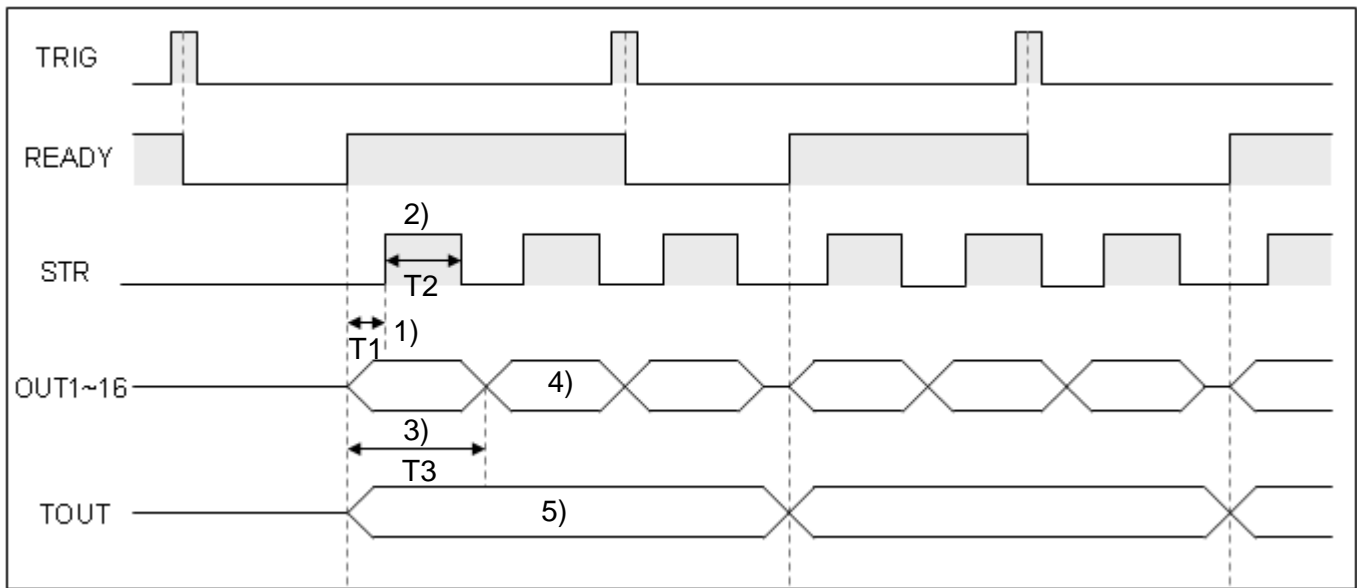

T1: Setup "STR delay" (unit: ms)

T2: Setup "STR duration" (unit: ms)

T3: Setup "Data output duration" (unit: ms)

Description:

- 1) When READY is ON, delay count begins for STR; STR is output after the delay count is reached.
- 2) The STR output period can be configured with the recommended stable read state on the controller.
- 3) OUT1–16 output period must satisfy the condition [data output duration \geq STR delay + STR duration].

■ Parallel I/O: (handshaking)

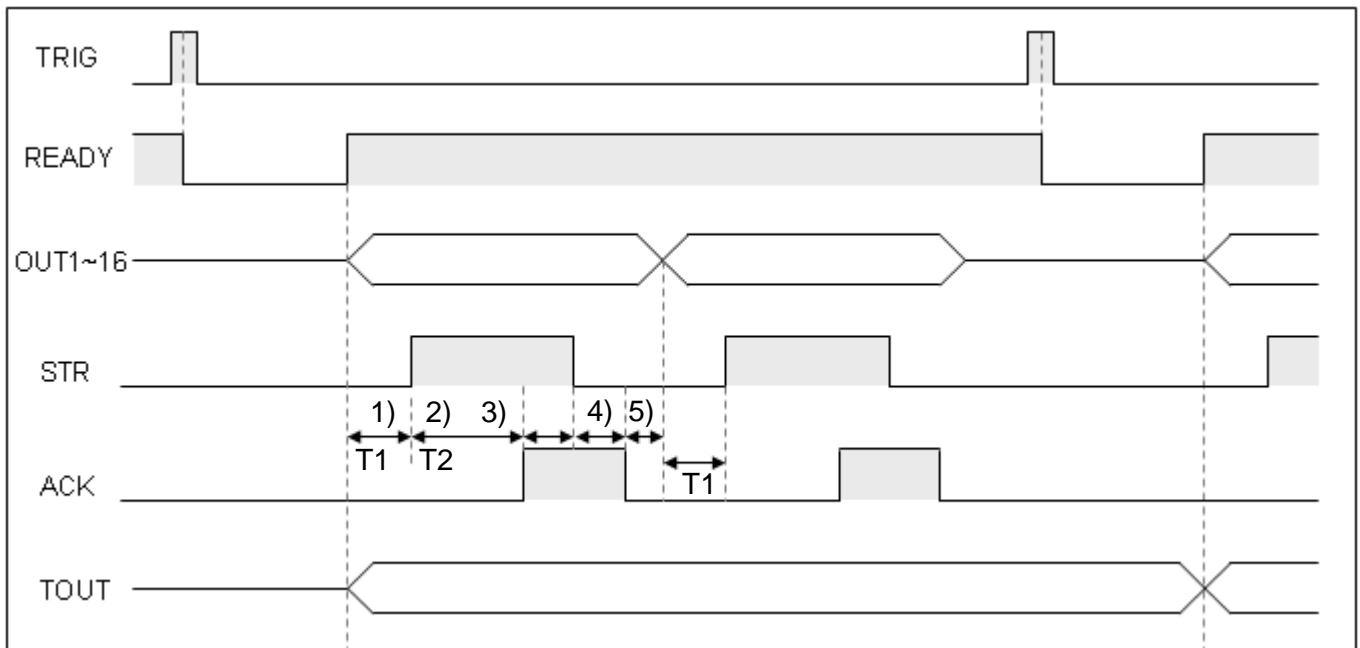

T1: Setup "STR delay" (unit: ms)

T2: Setup "Communication timeout" (unit: ms)

Description:

- 1) When READY is ON, delay count begins for STR; STR is output after the delay count is reached.
- 2) After STR is ON, the ACK handshaking signal should respond in the "Communication timeout" period. If not, the output is interrupted, the ERROR signal is sent out and the ERROR indicator light is lit.
- 3) After STR is output, it turns OFF after ACK is detected.
- 4) After STR is OFF, ACK also turns off to enable the next data output.
- 5) After ACK is off, the next batch of data is output.

■ Parallel I/O: (32-bit format)

In 32-bit output format, every data is divided into two parts before output.

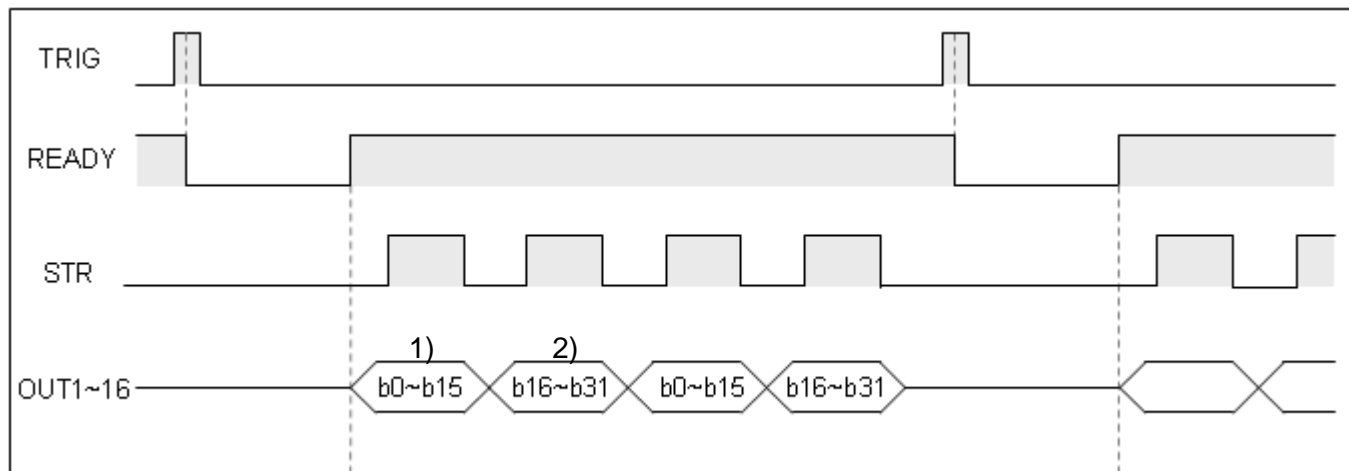

Description:

- 1) Leading 16 bits of the 32-bit data.
- 2) Trailing 16 bits of the 32-bit data.

i Remark

16-bit data range: Signed binary (-32768–32767) and unsigned binary (0–65535).
32-bit data range: -2147483648–2147483647

■ RS232, USB, ETHERNET, memory card, PLC-Link, and image save output

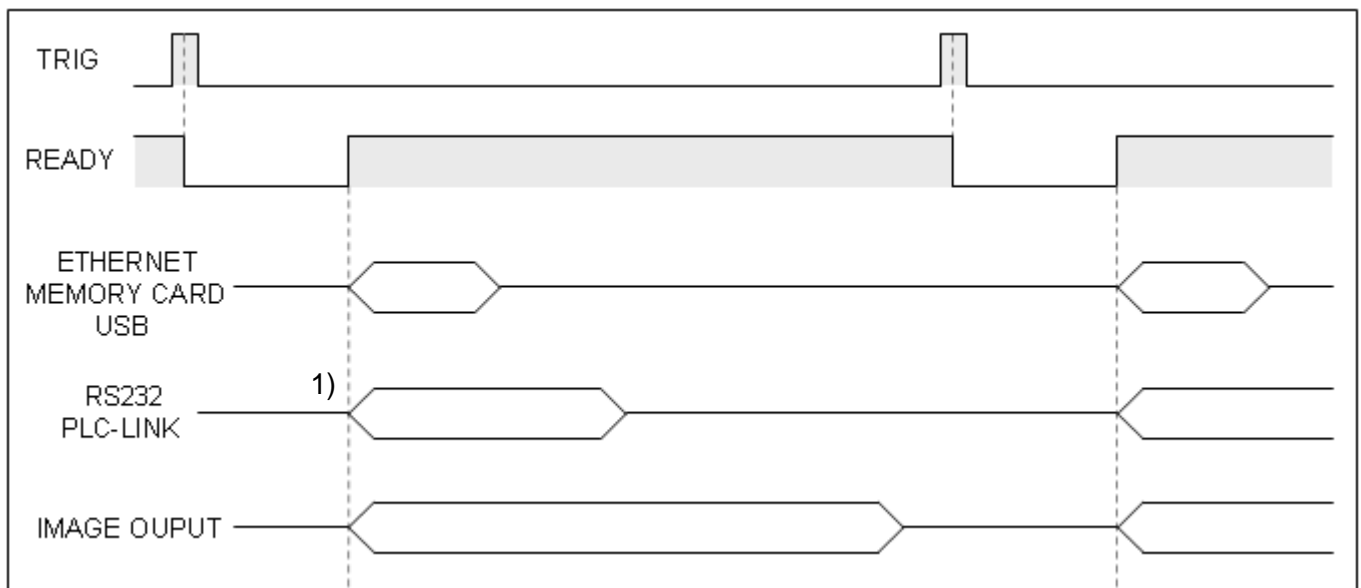

Description:

1) The outputs are in sync with the READY ON signal.



Remark Relative transfer speeds: ETHERNET > RS232 > IMAGE OUTPUT

8.1.5 Result output time

Excessively long result output times prolong the overall inspection time. The following describes the READY signal timing for different lengths of time in the result output.

■ Output time is less than inspection time (timing of READY signal)

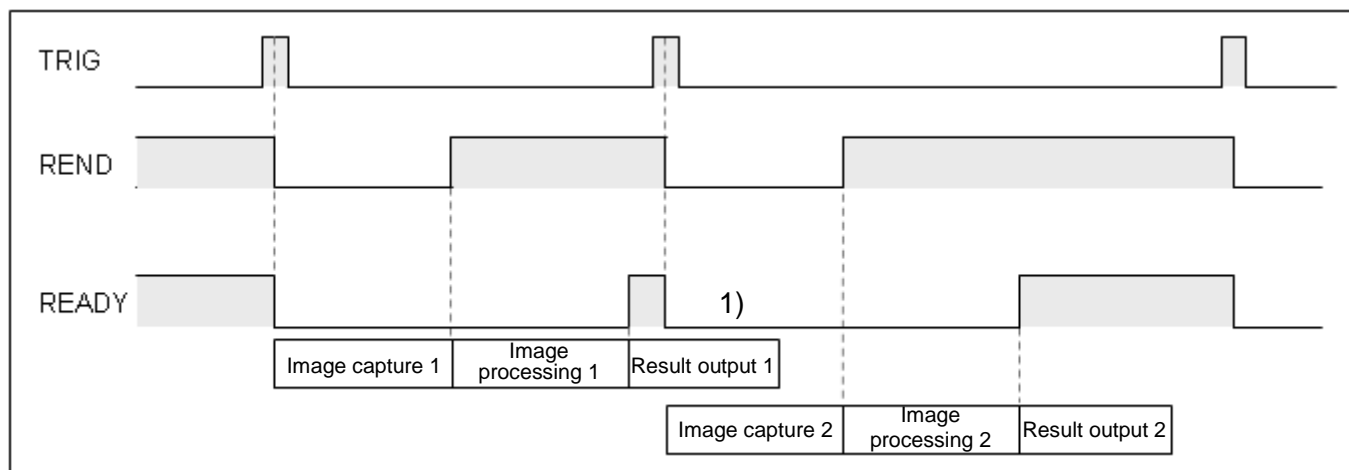

Description:

- 1) When “result output 1” is shorter than the next inspection time (image capture2 + image processing2), then the output does not affect the next inspection timing cycle.

■ Output time is greater than inspection time (timing of READY signal)

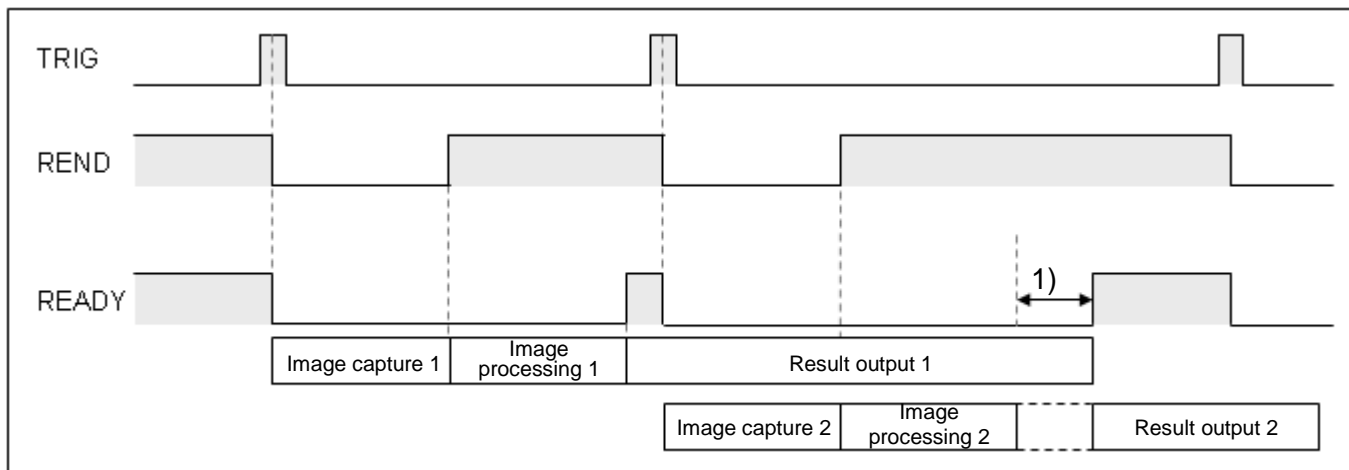

Description:

- 1) When “result output 1” is longer than the next inspection time (image capture2 + image processing2), then the next “result output 2” will be delayed until “result output 1” is finished. As a result, the READY signal timing is also delayed.

8.1.6 (Buffer) Image Save

Saving the image takes more time and may often exceed the inspection time. The system supports "Delayed save" and "Discard" saving modes.

■ Delayed save (all images are saved)

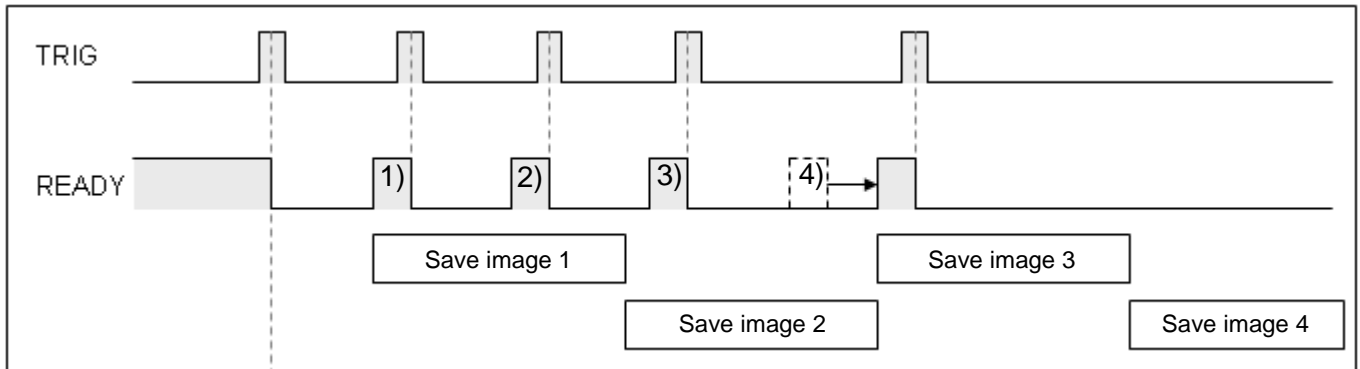

Description:

- 1) After the first inspection cycle, image1 save cycle starts.
- 2) After the second inspection cycle, image2 is stored to the buffer because image1 is still being saved.
- 3) After the third inspection cycle, image2 is now saving and image3 is stored to the buffer.
- 4) At the fourth inspection cycle, image2 is still saving and image3 is still in the buffer. The READY output signal is delayed until after image2 has been saved and then image4 is stored to the buffer.

■ Discard (discard save when buffer is full)

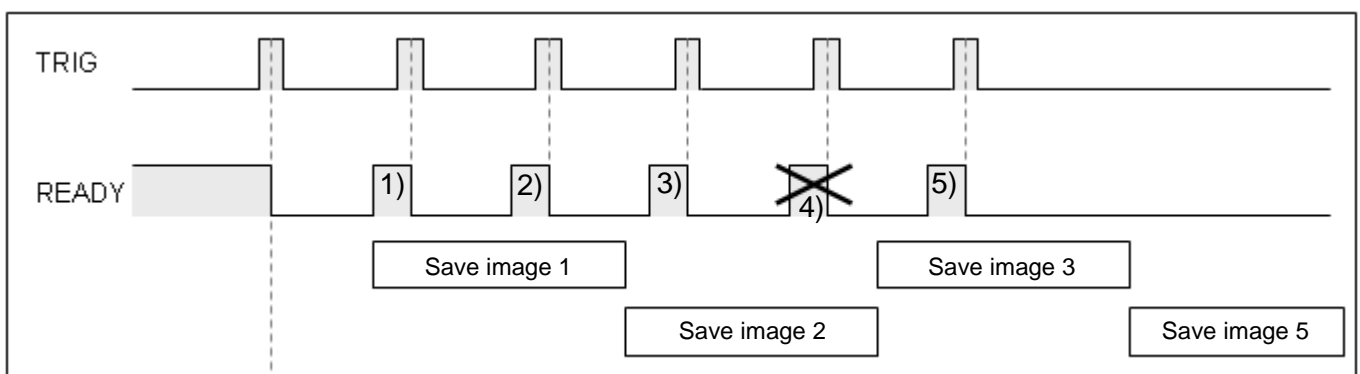

Description:

- 1) After the first inspection cycle, image1 save cycle starts.
- 2) After the second inspection cycle, image2 is stored to the buffer because image1 is still being saved.
- 3) After the third inspection cycle, image2 is now saving and image3 is stored to the buffer.
- 4) At the fourth inspection cycle, image2 is still saving and image3 is still in the buffer. The buffer is now full and image4 is discarded.
- 5) At the fifth inspection cycle, image3 is now saving and image5 is stored to the buffer.

8.1.7 Function switch: FNC1–4, IN1–8, FRDY, FCH, SW, NSW

The non-imaging and imaging inspection functions can be switched through the I/O terminals; for example switching between inspection projects or adjusting the camera shutter speed.

Function Selection				Description of Function	Set Value
FNC4	FNC3	FNC2	FNC1		IN8–IN1
OFF	OFF	OFF	OFF	0: Switch process (internal memory)	0–31 (IN5–IN1)
OFF	OFF	OFF	ON	1: Switch process (memory card)	
OFF	OFF	ON	OFF	2: Switch viewing window	0–127 (IN7–IN1)
OFF	OFF	ON	ON	3: Modify shutter speed	Shutter 0–9 (IN4–IN1); Camera No.0–1 (IN8)
OFF	ON	OFF	OFF	4: Camera gain	Gain 0–100 (IN7–IN1); Camera No.0–1 (IN8)
OFF	ON	OFF	ON	5: Camera brightness	Brightness 0–100 (IN7–IN1); Camera No.0–1 (IN8)
OFF	ON	ON	OFF	6: Image capture	N/A

■ IN8–IN1 Value Input Conversion Table (O=ON, X=OFF)

Numerical Value	Switch state							
	IN8	IN7	IN6	IN5	IN4	IN3	IN2	IN1
0	X	X	X	X	X	X	X	X
1	X	X	X	X	X	X	X	O
2	X	X	X	X	X	X	O	X
3	X	X	X	X	X	X	O	O
4	X	X	X	X	X	O	X	X
5	X	X	X	X	X	O	X	O
6	X	X	X	X	X	O	O	X
7	X	X	X	X	X	O	O	O
8	X	X	X	X	O	X	X	X
9	X	X	X	X	O	X	X	O
10	X	X	X	X	O	X	O	X
11	X	X	X	X	O	X	O	O
12	X	X	X	X	O	O	X	X
13	X	X	X	X	O	O	X	O
14	X	X	X	X	O	O	O	X
15	X	X	X	X	O	O	O	O
16	X	X	X	O	X	X	X	X
17	X	X	X	O	X	X	X	O
18	X	X	X	O	X	X	O	X
19	X	X	X	O	X	X	O	O
20	X	X	X	O	X	O	X	X
21	X	X	X	O	X	O	X	O
22	X	X	X	O	X	O	O	X
23	X	X	X	O	X	O	O	O
24	X	X	X	O	O	X	X	X
25	X	X	X	O	O	X	X	O

Numerical Value	Switch state							
	IN8	IN7	IN6	IN5	IN4	IN3	IN2	IN1
26	X	X	X	O	O	X	O	X
27	X	X	X	O	O	X	O	O
28	X	X	X	O	O	O	X	X
29	X	X	X	O	O	O	X	O
30	X	X	X	O	O	O	O	X
31	X	X	X	O	O	O	O	O
32	X	X	O	X	X	X	X	X
33	X	X	O	X	X	X	X	O
34	X	X	O	X	X	X	O	X
35	X	X	O	X	X	X	O	O
36	X	X	O	X	X	O	X	X
37	X	X	O	X	X	O	X	O
38	X	X	O	X	X	O	O	X
39	X	X	O	X	X	O	O	O
40	X	X	O	X	O	X	X	X
41	X	X	O	X	O	X	X	O
42	X	X	O	X	O	X	O	X
43	X	X	O	X	O	X	O	O
44	X	X	O	X	O	O	X	X
45	X	X	O	X	O	O	X	O
46	X	X	O	X	O	O	O	X
47	X	X	O	X	O	O	O	O
48	X	X	O	O	X	X	X	X
49	X	X	O	O	X	X	X	O
50	X	X	O	O	X	X	O	X
51	X	X	O	O	X	X	O	O

Numerical Value	Switch state							
	IN8	IN7	IN6	IN5	IN4	IN3	IN2	IN1
52	X	X	O	O	X	O	X	X
53	X	X	O	O	X	O	X	O
54	X	X	O	O	X	O	O	X
55	X	X	O	O	X	O	O	O
56	X	X	O	O	O	X	X	X
57	X	X	O	O	O	X	X	O
58	X	X	O	O	O	X	O	X
59	X	X	O	O	O	X	O	O
60	X	X	O	O	O	O	X	X
61	X	X	O	O	O	O	X	O
62	X	X	O	O	O	O	O	X
63	X	X	O	O	O	O	O	O
64	X	O	X	X	X	X	X	X
65	X	O	X	X	X	X	X	O
66	X	O	X	X	X	X	O	X
67	X	O	X	X	X	X	O	O
68	X	O	X	X	X	O	X	X
69	X	O	X	X	X	O	X	O
70	X	O	X	X	X	O	O	X
71	X	O	X	X	X	O	O	O
72	X	O	X	X	O	X	X	X
73	X	O	X	X	O	X	X	O
74	X	O	X	X	O	X	O	X
75	X	O	X	X	O	X	O	O
76	X	O	X	X	O	O	X	X
77	X	O	X	X	O	O	X	O
78	X	O	X	X	O	O	O	X
79	X	O	X	X	O	O	O	O
80	X	O	X	O	X	X	X	X
81	X	O	X	O	X	X	X	O
82	X	O	X	O	X	X	O	X
83	X	O	X	O	X	X	O	O
84	X	O	X	O	X	O	X	X
85	X	O	X	O	X	O	X	O
86	X	O	X	O	X	O	O	X
87	X	O	X	O	X	O	O	O
88	X	O	X	O	O	X	X	X
89	X	O	X	O	O	X	X	O

Numerical Value	Switch state							
	IN8	IN7	IN6	IN5	IN4	IN3	IN2	IN1
90	X	O	X	O	O	X	O	X
91	X	O	X	O	O	X	O	O
92	X	O	X	O	O	O	X	X
93	X	O	X	O	O	O	X	O
94	X	O	X	O	O	O	O	X
95	X	O	X	O	O	O	O	O
96	X	O	O	X	X	X	X	X
97	X	O	O	X	X	X	X	O
98	X	O	O	X	X	X	O	X
99	X	O	O	X	X	X	O	O
100	X	O	O	X	X	O	X	X
101	X	O	O	X	X	O	X	O
102	X	O	O	X	X	O	O	X
103	X	O	O	X	X	O	O	O
104	X	O	O	X	O	X	X	X
105	X	O	O	X	O	X	X	O
106	X	O	O	X	O	X	O	X
107	X	O	O	X	O	X	O	O
108	X	O	O	X	O	O	X	X
109	X	O	O	X	O	O	X	O
110	X	O	O	X	O	O	O	X
111	X	O	O	X	O	O	O	O
112	X	O	O	O	X	X	X	X
113	X	O	O	O	X	X	X	O
114	X	O	O	O	X	X	O	X
115	X	O	O	O	X	X	O	O
116	X	O	O	O	X	O	X	X
117	X	O	O	O	X	O	X	O
118	X	O	O	O	X	O	O	X
119	X	O	O	O	X	O	O	O
120	X	O	O	O	O	X	X	X
121	X	O	O	O	O	X	X	O
122	X	O	O	O	O	X	O	X
123	X	O	O	O	O	X	O	O
124	X	O	O	O	O	O	X	X
125	X	O	O	O	O	O	X	O
126	X	O	O	O	O	O	O	X
127	X	O	O	O	O	O	O	O

■ Non-imaging mode

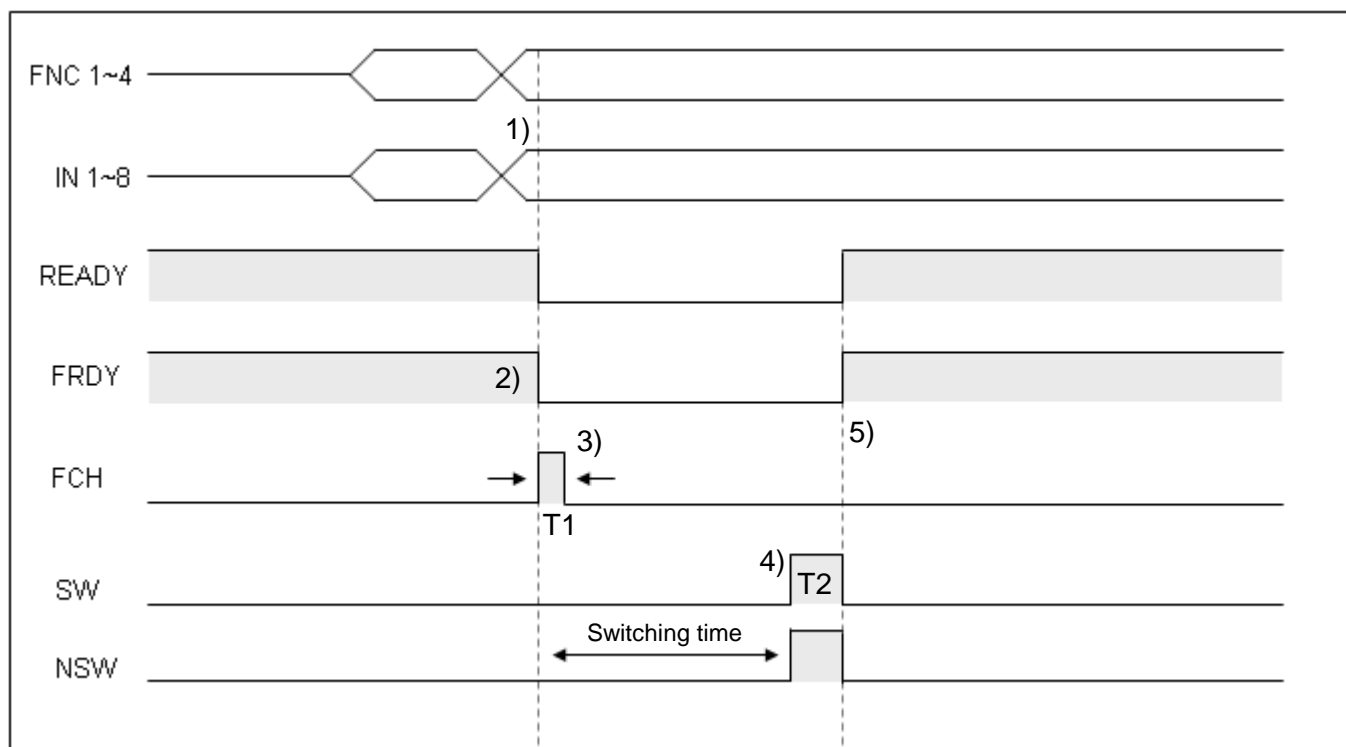

Description:

- 1) Enable FNC1–4 and IN1–8 to set up the function and parameters.
- 2) FRDY (Function Ready) is ON to enable function switching.
- 3) Trigger FCH (Function Change) to execute function switching. T1 must be longer than 1 ms. After FCH is enabled, READY and FRDY are OFF.
- 4) After the switch is made, set the output flags SW (success) or NSW (failed). If switching is disabled or illegal, set the NSW flag output.
(T2 is configured in [System] > [Communication] > [External])
- 5) After setting SW or NSW outputs, READY and FRDY signals return to the ON state.

■ Imaging mode

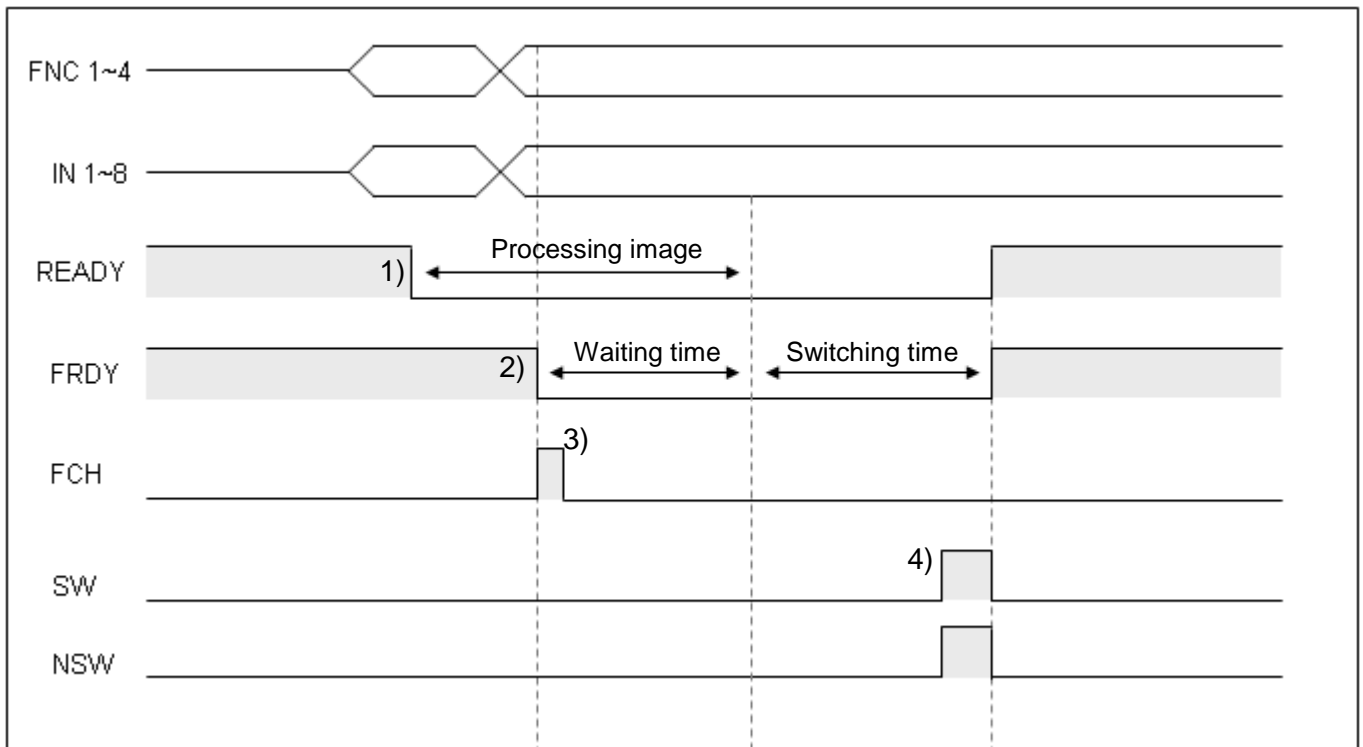

Description:

- 1) READY is OFF, indicating the system is currently processing the image.
- 2) FRDY is ON, function switching is enabled.
- 3) FCH is triggered to initiate function switching (T1 must be longer than 1 ms). After FCH is enabled, FRDY is OFF.
Image processing must be completed before the function can be switched.
- 4) After the switch is made, set the output flags SW (success) or NSW (failed).

8.1.8 Other: TROFF, TEST, PLINK, RESET

■ TROFF (trigger disabled)

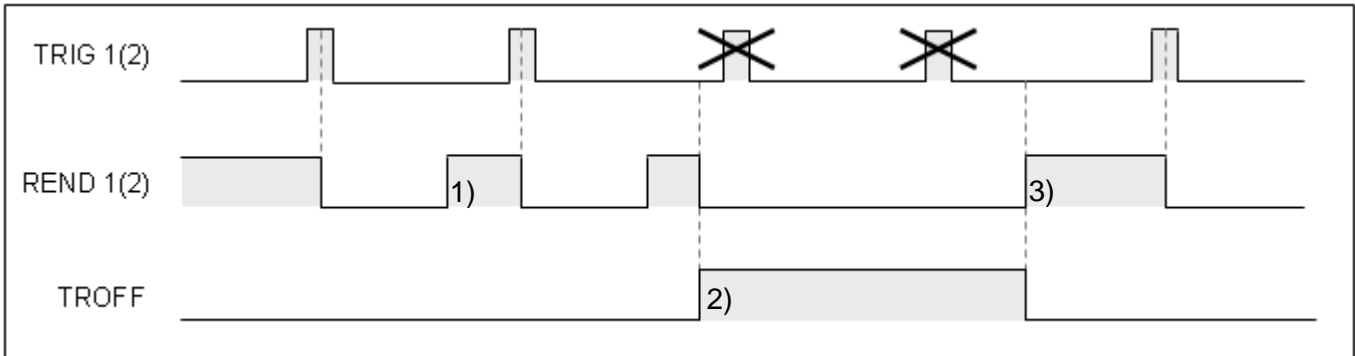

Description:

- 1) During standard timing sequence, REND is ON after the image is captured to allow the next trigger input.
- 2) When TROFF input is ON, REND1 and REND2 are disabled at the same time. You can use either the TROFF or REND signals as the trigger point.
- 3) When TROFF is OFF, REND1 and REND2 signals resume normal operation.

■ TEST (output disabled)

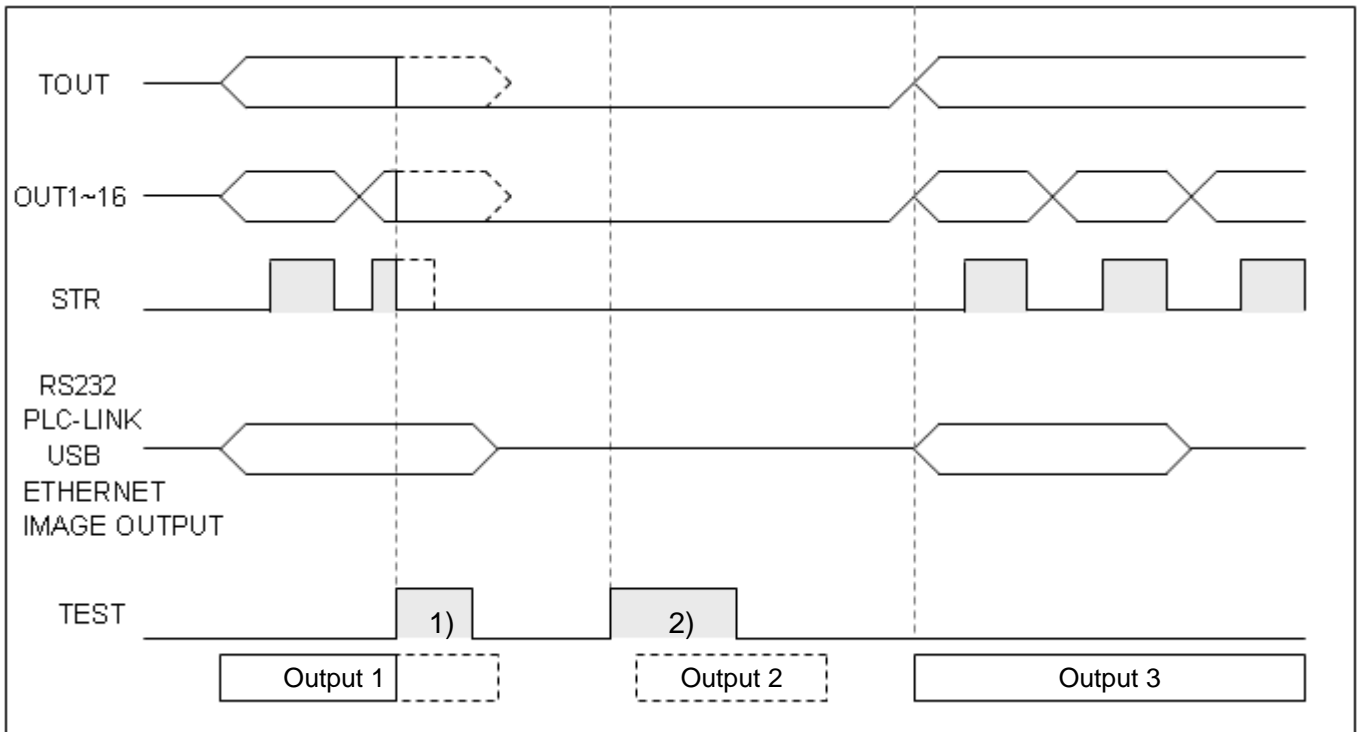

Description:

- 1) Output1 is valid before TEST input is ON, all external output terminals are OFF and communication output is uninterrupted until the sequence ends.
- 2) TEST input is ON before output2 is valid, external output terminals and communications are disabled.

- PLINK (data link to PLC):

This feature is currently being developed.

- RESET:

When RESET signal input is enabled, all outputs are disabled.

Chapter 9

Serial Communication

9.1 RS232

The system supports two types of RS232 communication methods.

1) RS232 Result output mode

Inspection result is directly output to the RS232 port, and you to decode the data format.

2) RS232 PLC-LINK mode

Inspection result is automatically written to and then easily accessed from the PLC register. This eliminates the need to decode the data upon reception.

Auto PLC-LINK is only supported with the Delta DVP series.

3) RS232 Slave mode

The controller automatically switches to the slave mode from "RS232 Result output mode" if no strings are to be output. In this mode, the controller waits for an external serial command to be executed and acknowledged. Refer to Section 9.4 for more information about slave mode commands.

For example, a serial command is issued to the controller for project switching (in slave mode); the acknowledgement is returned after the project has been switched.

Remark Both "Result output mode" and "PLC-LINK mode" occupy the RS232 interface and cannot be enabled at the same time. Select the mode from the settings.

9.2 Result output mode

■ Setup protocol

From [System] > [Communication], select the RS232 communication protocol.

Default baud rate: 9600 (2,400–115,200 bps)

Length: 7 (7, 8)

Parity: Even (odd, even, none)

Stop bit: 1 (1, 2)

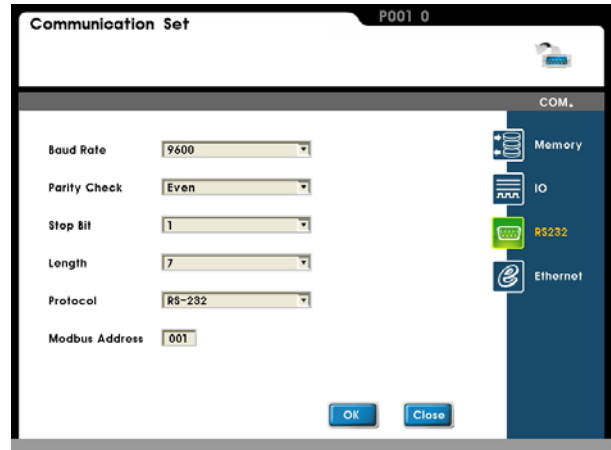

■ Output format

From [Program] > [Output] > [RS232], select [Set] and set the string length for "Result output mode."

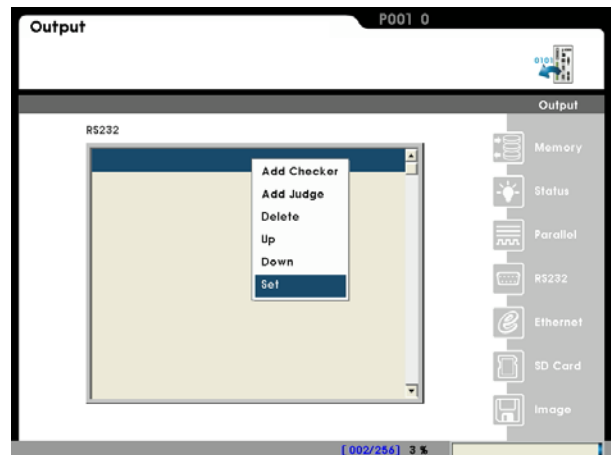

[RS232] option must be enabled when setting the "Result output mode."

[Data length] is the fixed length of each output data.

For example, an output value of 123.45 denotes the RS232 output string of 12345 (decimal point is ignored) requiring a minimum length of 5. Similarly,

a minimum length of 4 is required to output 56.78

The negative sign of a number also takes up a character, therefore -123.45 requires a minimum string length of 6 (-12345 is the output).



● Set data length to the longest valid string from multiple results to ensure a correct output. For example, set data length to 6 if the output data are 34.56 (length 4), 123 (length 3), 123.45 (length 5), and -123.45 (length 6). As 0's are pre-pended to the front of the shorter strings, the output string is 003456000123012345-12345

● Judgment output carries only the 0 and 1 flag. As shown to the right, the output string is 001 if bit15 = NG (0), bit13 = NG (0), and bit12 = OK (1).

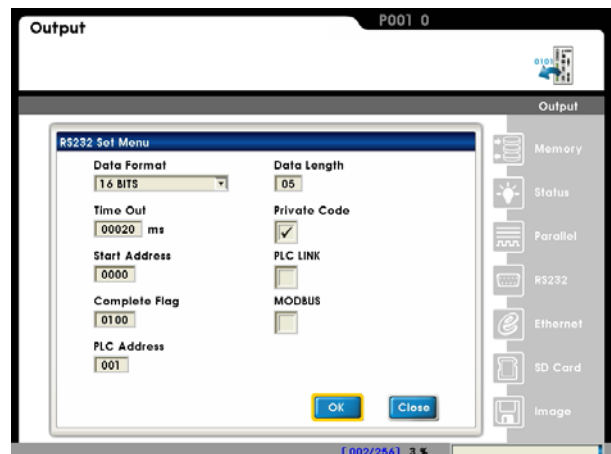

9.3 PLC-LINK mode

The system automatically writes the inspection result to the PLC register and the program developer can directly access the data from the PLC register without needing to decode the data format.

■ +Setup protocol

From [System] > [Communication], select the RS232 communication protocol.

Default baud rate: 9600 (2,400–115,200 bps)

Length: 7 (7, 8)

Parity: Even (odd, even, none)

Stop bit: 1 (1, 2)

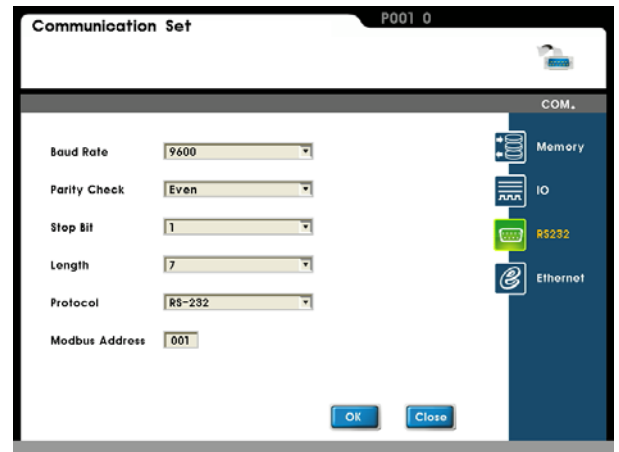

■ Output format

From [Program] > [Output] > [RS232], select [Set] and set the string length for "Result output mode."

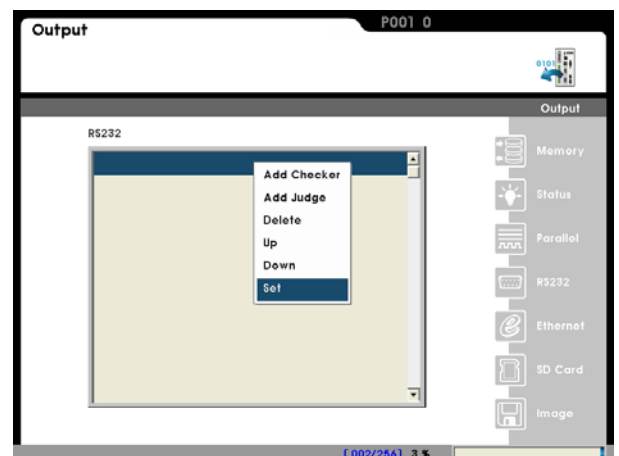

- You must select [PLC LINK] to enable the "PLC LINK mode".
- [Data format]: Select 32-bit (double word) mode if the output data exceeds the range -32,767–32,768.
- [Time out]: Timeout for communication between DMV and PLC.
- [Start address]: Starting address to write to PLC. For example, enter 100 to start writing from the D100 register address.

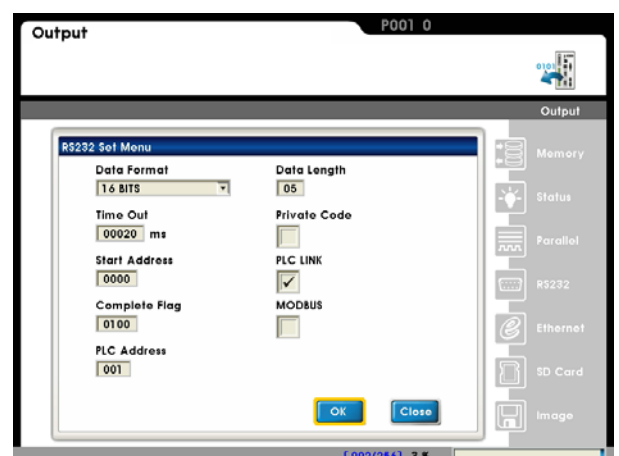

- [Complete flag]: After all data are written into the PLC register, the DMV1000 sets this register to 1 for the PLC to confirm that writing is complete. After PLC confirms the data write access, manually set the [Complete flag] register to 0 for the next write access.
- [PLC Code]: PLC code to connect.

9.4 Slave mode

While not in the data output state, the controller automatically switches to the slave mode to respond to external commands.

9.4.1 Slave mode command table (DMV communication format)

	Function	Input string	Return string	Permission	
				Run	Program
1	Trigger 1 action and output	T1 <input type="text"/>	T1 <input type="text"/> T0 + output <input type="text"/>	O	
2	Trigger 2 action and output	T2 <input type="text"/>	T2 <input type="text"/> T0 + output <input type="text"/>	O	
3	Go to run mode	RN <input type="text"/>	RN <input type="text"/>		O
4	Go to program mode	PG <input type="text"/>	PG <input type="text"/>	O	
5	Repeat data output	DQ <input type="text"/>	DQ+ output <input type="text"/>	O	
6	Switch program ID (memory)	PCINnn <input type="text"/>	PC <input type="text"/>	O	
7	Switch program ID (SD card)	PCSDnnnn <input type="text"/>		O	
8	Read program ID	PR <input type="text"/>	PRINnn <input type="text"/>	O	
			PRSDnnnn <input type="text"/>		
9	Switch window ID	WCnnnn <input type="text"/>	WC <input type="text"/>	O	
10	Read window ID	WR <input type="text"/>	WRnnnn <input type="text"/>	O	
11	Capture image	CP <input type="text"/>	CP <input type="text"/>	O	O
12	Enable input trigger	TO <input type="text"/>	TO <input type="text"/>	O	
13	Disable input trigger	TF <input type="text"/>	TF <input type="text"/>	O	
14	Write upper/lower limit (inspection)	LWWmnnnnnaaaaaaabb bbb <input type="text"/>	LW <input type="text"/>	O	
15	Write upper/lower limit (calculator)	LWCAnnaaaaaaabb bbb <input type="text"/>	LC <input type="text"/>	O	
16	Read upper/lower limit (inspection)	LRWmnnnn <input type="text"/>	LRaaaaaabb bbb <input type="text"/>	O	
17	Read upper/lower limit (calculator)	LRCAnn <input type="text"/>	LRaaaaaabb bbb <input type="text"/>	O	
18	Save all project settings	SV <input type="text"/>	SV <input type="text"/>		O
19	Set time/date	DWyyymmddhhmmss <input type="text"/>	DW <input type="text"/>	O	O
20	Read time/date	DR <input type="text"/>	DRyyymmddhhmmss <input type="text"/>	O	O

	Function	Input string	Return string	Permission	
				Run	Program
21	Set camera shutter speed	SHCnmm <input type="text"/>	SH <input type="text"/>	O	
22	Set camera gain and brightness	SECnmmkk <input type="text"/>	SE <input type="text"/>	O	
23	Clear statistics	QC <input type="text"/>	QC <input type="text"/>	O	O
24	System reset	RS <input type="text"/>	RS <input type="text"/>	O	
25	Change password	PSnnnnmmmm <input type="text"/>	PS <input type="text"/>	O	O
26	Simulate keypad input	KYnn <input type="text"/>	KY <input type="text"/>	O	O
27	Write to memory	MWnnaaaaaaaa <input type="text"/>	MW <input type="text"/>	O	O
28	Read from memory	MRnn <input type="text"/>	MRaaaaaaaa <input type="text"/>	O	O

9.4.2 Slave mode commands (DMV communication format)

1) Trigger 1 action and output (RUN mode)

Input string: T1 Return string: T1 T0 + output

Description: Set string length to 5 for 2 data (1234, 345) and 3 judgments (1, 0, 1) in the case of integers.

Return: T1 T00123400345101

Set string length to 5 for 2 data (12.3, 34.5) and 3 judgments (1, 0, 1) in the case of integers.

Return: T1 T01230034500101

System returns T1 upon receiving the command and then returns the result after inspection completes. Inspection time varies with the inspection item. Adjust the controller timeout if inspection time is too long.

Remark If both cameras are enabled simultaneously, use [Program] > [Camera] > [Trigger mode] to set the trigger action.

Error handling: Return string

- E01: Incorrect permission mode (incorrect RUN/PROG mode)
- E02: Incorrect string data (string length is too long or too short to be decoded)
- E03: READY is not ON and cannot run (check the I/O status)

2) Trigger 2 action and output (RUN mode)

Input string: T2 Return string: T2 T0 + output

Description: Set string length to 5 for 2 data (1234, 345) and 3 judgments (1, 0, 1) in the case of integers.

Return: T2 T00123400345101

Set string length to 5 for 2 data (12.3, 34.5) and 3 judgments (1, 0, 1) in the case of integers.

Return: T2 T01230034500101

System returns T2 upon receiving the command and then returns the result after inspection completes. Inspection time varies with the inspection item. Adjust the controller timeout if inspection time is too long.

Remark

Error handling: Return string

- E01: Incorrect permission mode (incorrect RUN/PROG mode)
- E02: Incorrect string data (string length is too long or too short to be decoded)
- E03: READY is not ON and cannot run (check the I/O status)

3) To RUN mode (program mode)

Input string: RN Return string: RN

Error handling: Return string

- E01: Incorrect permission mode (incorrect RUN/PROG mode)
- E02: Incorrect string data (string length is too long or too short to be decoded)
- E04: FRDY (function ready) is not ON and cannot run (check the I/O status)

4) To Setting Mode (RUN mode)

Input string: PG Return string: PG

Error handling: Return string

- E01: Incorrect permission mode (incorrect RUN/PROG mode)
- E02: Incorrect string data (string length is too long or too short to be decoded)
- E04: FRDY (function ready) is not ON and cannot run (check the I/O status)

5) Repeat data output (RUN mode)

Input string: DQ Return string: DQ + output

Description: Controller returns the latest inspection result.

It returns an error message if there is no inspection result to return; for example, after system boot up before an inspection cycle.

Error handling: Return string

- E01: Incorrect permission mode (incorrect RUN/PROG mode)
- E02: Incorrect string data (string length is too long or too short to be decoded)
- E05: No inspection result (data not available)

6) Switch program ID - memory (RUN mode)

Input string: PCINnn Return string: PC

Description: nn is the program ID (valid internal memory P00–P31).

Enter the string to switch to P03: PCIN03

Error handling: Return string

- E01: Incorrect permission mode (incorrect RUN/PROG mode)
- E02: Incorrect string data (string length is too long or too short to be decoded)
- E04: FRDY (function ready) is not ON and cannot run (check the I/O status)
- E06: No program ID (program ID not set)

7) Switch program ID - SD card (RUN mode)

Input string: PCSDnnnn Return string: PC

Description: nnnn is the program ID.

Enter the string to switch to P03: PCSD0003

Error handling: Return string

- E01: Incorrect permission mode (incorrect RUN/PROG mode)
- E02: Incorrect string data (string length is too long or too short to be decoded)
- E04: FRDY (function ready) is not ON and cannot run (check the I/O status)
- E06: No program ID (program ID not set)
- E08: No SD card

8) Read program ID (RUN mode)

Input string: PR Return string: (internal memory) PRINnn
(SD card) PRSDnn

Description: nn is the program ID.

Controller returns the string for internal program memory ID P03: PCIN03

Error handling: Return string

- E01: Incorrect permission mode (incorrect RUN/PROG mode)
- E02: Incorrect string data (string length is too long or too short to be decoded)

9) Switch window ID (RUN mode)

Input string: WCnnn Return string: WC

Description: nnn is the window ID (valid window ID range W00–W127).

Enter the string to switch to W015: WC015

Error handling: Return string

- E01: Incorrect permission mode (incorrect RUN/PROG mode)
- E02: Incorrect string data (string length is too long or too short to be decoded)
- E04: FRDY (function ready) is not ON and cannot run (check the I/O status)
- E07: No window ID (including window ID not set)

10) Read window ID (RUN mode)

Input string: WR Return string: WRnnn

Description: nnn is the window ID.

Controller returns the string for window ID W020: WR020

Error handling: Return string

- E01: Incorrect permission mode (incorrect RUN/PROG mode)
- E02: Incorrect string data (string length is too long or too short to be decoded)

11) Capture image (RUN/PROG mode)

Input string: CP Return string: CP

Description: Copy current screen to SD card. Image is saved as 800*600.

Error handling: Return string

- E02: Incorrect string data (string length is too long or too short to be decoded)
- E08: No SD card found
- E09: Insufficient memory or SD card space

12) Enable input trigger (RUN mode)

Input string: TO Return string: TO

Description: Controller defaults to "trigger enabled" state at each boot up, therefore you can use this with the "disable input trigger" command.

Error handling: Return string

- E01: Incorrect permission mode (incorrect RUN/PROG mode)
- E02: Incorrect string data (string length is too long or too short to be decoded)

13) Disable input trigger (RUN mode)

Input string: TF Return string: TF

Description: Disable all enabled trigger sources.

Set trigger source from [Program]> [Camera] > [Trigger].

Error handling: Return string

- E01: Incorrect permission mode (incorrect RUN/PROG mode)
- E02: Incorrect string data (string length is too long or too short to be decoded)

14) Write upper/lower limit - inspection window (RUN mode)

Input string: LWWmnnnnnaaaaaaabbabbbb Return string: LW

Description: m (data ID), nnnn (window ID), aaaaaaaa (upper limit), bbbabbbb (lower limit).

Upper/lower limits are fixed 8-digit numbers.

To set the upper/lower limits of W015 to 300 and 200 respectively, enter the string

LWW200150000030000000200

If the upper/lower input limits are coordinates or angle data (hundredth decimal format), the string format is described below.

For upper/lower angle limits of 120.00 and 50.00, enter LWW200150001200000005000

Error handling: Return string

- E01: Incorrect permission mode (incorrect RUN/PROG mode)
- E02: Incorrect string data (string length is too long or too short to be decoded)
- E04: FRDY (function ready) is not ON and cannot run (check the I/O status)
- E07: No window ID (including window ID not set)
- E10: Upper/lower limit error (invalid range or upper is less than lower)
- E11: Incorrect data ID (not available from current inspection)

15) Write upper/lower limit - calculator (RUN mode)

Input string: LWCAnnaaaaaaabbabbbb Return string: LC

Description: nn (calculator ID), aaaaaaaa (upper limit), bbbabbbb (lower limit). Upper/lower limits are fixed 8-digit numbers.

To set the calculator's upper/lower limits of C25 to 123.45 and 12.34, enter the string

LWCA250001234500001234

Error handling: Return string

- E01: Incorrect permission mode (incorrect RUN/PROG mode)
- E02: Incorrect string data (string length is too long or too short to be decoded)
- E04: FRDY (function ready) is not ON and cannot run (check the I/O status)
- E10: Upper/lower limit error (invalid range or upper is less than lower)
- E11: Incorrect data ID (not available from current inspection)

16) Read upper/lower limit - inspection window (RUN mode)

Input string: LRWmnnnn Return string: LRaaaaaabbbbb

Description: m (data ID), nnnn (window ID), aaaaaaa (upper limit), bbbbbbb (lower limit).

Upper/lower limits are fixed 8-digit numbers.

To read the upper/lower limits of W015 from 300 and 200, enter the string LRW20015

Return string LR0000030000000200

If the upper/lower read limits are coordinates or angle data (hundredth decimal format), the string format is described below.

Upper/lower limits are 120.00 and 50.00, the return string is LR0001200000005000

Error handling: Return string

- E01: Incorrect permission mode (incorrect RUN/PROG mode)
- E02: Incorrect string data (string length is too long or too short to be decoded)
- E07: No window ID (including window ID not set)
- E11: Incorrect data ID (not available from current inspection)

17) Read upper/lower limit - calculator (RUN mode)

Input string: LRCAnn Return string: LRaaaaaaaabbbbbbb

Description: nn (calculator ID), aaaaaaa (upper limit), bbbbbbb (lower limit). Upper/lower limits are fixed 8-digit numbers.

To read the calculator's upper/lower limits of C25 from 123.45 and 12.34, the return string is

LR0001234500001234

Error handling: Return string

- E01: Incorrect permission mode (incorrect RUN/PROG mode)
- E02: Incorrect string data (string length is too long or too short to be decoded)

18) Save all project settings (program mode)

Input string: SV Return string: SV

Error handling: Return string

- E01: Incorrect permission mode (incorrect RUN/PROG mode)
- E02: Incorrect string data (string length is too long or too short to be decoded)
- E08: No SD card found.
- E09: Insufficient memory or SD card space

19) Set time/date (RUN/PROG mode)

Enter string : DWyymmddhhmmss Return string: DW

Error handling: Return string

- E02: Incorrect string data (string length is too long or too short to be decoded)
- E15: Incorrect calendar format.

20) Read time/date (RUN/PROG mode)

Input string: DR Return string: DRyymmddhhmmss

Error handling: Return string

- E02: Incorrect string data (string length is too long or too short to be decoded)

21) Set camera shutter speed (RUN mode)

Input string: SHCnmm Return string: SH

Description: Cn (camera ID), mm (shutter speed).

Shutter speed table (range 01–15)

01= 1 s	05=1/100 s (10 ms)	09=1/1000 s (1 ms)	13=1/10000 s (0.1 ms)
02=1/2 s (500 ms)	06=1/120 s (8 ms)	10=1/2000 s (0.5 ms)	14=1/20000 s (0.05 ms)
03=1/15 s (66 ms)	07=1/240 s (4 ms)	11=1/4000 s (0.25 ms)	15= Custom
04=1/30 s (33 ms)	08=1/500 s (2 ms)	12=1/5000 s (0.2 ms)	

Error handling: Return string

- E01: Incorrect permission mode (incorrect RUN/PROG mode)
- E02: Incorrect string data (string length is too long or too short to be decoded)
- E12: Incorrect camera settings.

22) Set camera gain and brightness (RUN mode)

Input string: SECnmmkk Return string: SE

Description: Cn (camera ID), mm (gain), kk (brightness) (mm and kk are limited to 00–99)

Error handling: Return string

- E01: Incorrect permission mode (incorrect RUN/PROG mode)
- E02: Incorrect string data (string length is too long or too short to be decoded)
- E12: Incorrect camera settings.

 **Remark** Higher gain can compensate for insufficient lighting, but may also add noise to the image.

23) Clear statistics (RUN/PROG mode)Input string: QC Return string: QC **Error handling:** Return string

- E02: Incorrect string data (string length is too long or too short to be decoded)

24) Reset system (RUN mode)Input string: RS Return string: RS **Description:** The following data is reset:

Total, NG, defect rate, statistics, output terminals.

Error handling: Return string

- E01: Incorrect permission mode (incorrect RUN/PROG mode)
- E02: Incorrect string data (string length is too long or too short to be decoded)

25) Change password (RUN/PROG mode)Input string: PSnnnnmmmm Return string: PS **Description:** nnnn (old password), mmmm (new password). Password must be a 4-digit number (range 0000–9999).**Error handling:** Return string

- E02: Incorrect string data (string length is too long or too short to be decoded)
- E14: Incorrect password (incorrect password or wrong format for new password)

26) Simulate keypad input (RUN/PROG mode)Input string: KYnn Return string: KY **Description:** nn (keypad code)

01 = Up	05 = ENTER	09 = FUNCTION
02 = Down	06 = RUN/STOP	10 = DISPLAY
03 = Right	07 = ESC	11 = CUSTOM
04 = Left	08 = TRIGGER	

Error handling: Return string

- E02: Incorrect string data (string length is too long or too short to be decoded)
- E13: Incorrect keypad code (range 01–11)

27) Write memory (RUN/PROG mode)

Input string: MWnnaaaaaaaa Return string: MW

Description: nn (16 memory addresses), aaaaaaaaa (write with two decimal digits at the end) (range -9999999–9999999)

Error handling: Return string

- E02: Incorrect string data (string length is too long or too short to be decoded)

28) Read memory (RUN/PROG mode)

Input string: MRnn Return string: MRaaaaaaaa

Description: nn (16 memory addresses), aaaaaaaaa (read with two decimal digits at the end)

Error handling: Return string

- E02: Incorrect string data (string length is too long or too short to be decoded)

Error code table

Error code	Description
E01	Incorrect mode (RUN/PROG mode)
E02	Incorrect string data (string length is too long or too short to be decoded)
E03	READY is not ON and cannot run (check the I/O status)
E04	FRDY (function ready) is not ON and cannot run (check the I/O status)
E05	No inspection result (data not available)
E06	No program ID (program ID not set)
E07	No window ID (including window ID not set)
E08	No SD card
E09	Insufficient memory or SD card space
E10	Upper/lower limit error (invalid range or upper is less than lower)
E11	Incorrect data ID (not available from current inspection)
E12	Incorrect camera settings
E13	Incorrect keypad code (range 01–11)
E14	Incorrect password (incorrect password or wrong format for new password)
E15	Incorrect calendar format

9.4.3 Slave mode command table (Modbus communication format)

The system supports only ASCII mode. Refer to Section 9.6 ASCII table for more information on converting between hexadecimal and ASCII.

R is the Read command (03 code up to 64 reads).

W is the Write command (single write: 06 code; multiple writes: 10 code up to 6 writes).

Read 03 command: read single or multiple data controlled by the [Byte] parameter

Output format

:	01	03	1010	0002	DA	CR	LF
Header	Device number	Function code (read)	Function address	Data ID	Parity	Suffix	

Return format:

:	01	03	04	0010	0015	D8	CR	LF
Header	Device number	Function code (read)	Data ID (byte)	Result 1	Result 2	Parity	Suffix	

Write 06 single data (the correctly written data string is returned as is)

Output format

:	01	06	1000	0001	E8	CR	LF
Header	Device number	Function code (write)	Function address	Write data	Parity	Suffix	

Return format:

:	01	06	1000	0001	E8	CR	LF
Header	Device number	Function code (write)	Function address	Write data	Parity	Suffix	

Write 10 multiple data (up to 6 writes)

Output format

:	01	10	1070	0002	04	0060	0015	F4	CR	LF
Header	Device number	Function code	Function address	Writes	Bytes	Data 1	Data 2	Parity	Suffix	

Return format:

:	01	10	1070	0002	6D	CR	LF
Header	Device number	Function code	Function address	Writes	Parity	Suffix	

Chapter 9: Serial Communication

Check parity:

Sum two-by-two, then take the two's complement of the last two digits (add in hexadecimal without header)

For example: 0110107000020400600015 F4 CR LF

$01+10+10+70+00+02+04+00+60+00+15 = 10C$ (last two digits are 0C)

1's complement = $FF - 0C = F3$ (difference from FF)

2's complement = $F3 + 1 = F4$ (2's complement is 1 added to 1)

Address	Title	Description	Permission	
			Run	Program
1000H (W)	Trigger 1 action	Trigger if Data 1 is written	O	
1001H (W)	Trigger 2 action	Trigger if Data 1 is written	O	
1010H (R) – 104FH (R)	Output data (total 64 outputs)	Refer to the description below for more information on the output data.	O	
1050H (W)	Switch to RUN mode	Trigger if Data 1 is written		O
1051H (W)	Switch to PROG mode	Trigger if Data 1 is written	O	
1060H (R/W)	Read/switch program ID	0–255 (0–31 on internal memory, 32–255 on SD card)	O	
1062H (R/W)	Read/switch window ID	0–127	O	
1070H (R/W)	Read upper/lower limit (window)	Data ID to read	O	
1071H (R/W)		Window ID to read		
1072H (R)		Read upper limit (Low word)		
1073H (R)		Read upper limit (High word)		
1074H (R)		Read lower limit (Low word)		
1075H (R)		Read lower limit (High word)		
1077H (W)		Write upper/lower limit (window)		
1078H (W)	Window ID to write			
1079H (W)	Write upper limit (Low word)			
107AH (W)	Write upper limit (High word)			
107BH (W)	Write lower limit (Low word)			
107CH (W)	Write lower limit (High word)			
1080H (R/W)	Read upper/lower limit (calculator)	Calculator ID to read	O	
1081H (R/W)		Read upper limit (Low word)		
1082H (R)		Read upper limit (High word)		
1083H (R)		Read lower limit (Low word)		
1084H (R)		Read lower limit (High word)		
1086H (W)	Write upper/lower limit (calculator)	Calculator ID to write	O	
1087H (W)		Write upper limit (Low word)		
1088H (W)		Write upper limit (High word)		

1089H (W)		Write lower limit (Low word)		
108AH (W)		Write lower limit (High word)		
1090H (R/W)	Read/set date and time	Year (00–99)	○	○
1091H (R/W)		Month (01–12)		
1092H (R/W)		Day (01–31)		
1093H (R/W)		Hour (00–23)		
1094H (R/W)		Minute (00–59)		
1095H (R/W)		Second (00–59)		
10A0H (W)		Set camera shutter speed		
10A1H (W)	Shutter speed (1–15)			
10A2H (W)	Set camera gain and brightness	Camera ID (1–2)	○	
10A3H (W)		Gain (00–99)		
10A4H (W)		Brightness (00–99)		
10A5H (W)	Change password	Old password (4 digits)	○	○
10A6H (W)		New password (4 digits)		
10B0H (W)	Enable input trigger	Trigger if Data 1 is written	○	
10B1H (W)	Disable input trigger	Trigger if Data 1 is written	○	
10B2H (W)	Save all project settings	Trigger if Data 1 is written		○
10B3H (W)	Capture image	Trigger if Data 1 is written	○	○
10B4H (W)	Clear statistics	Trigger if Data 1 is written	○	○
10B5H (W)	System reset	Trigger if Data 1 is written	○	
10C0H (W)	Simulate keypad input	1–11	○	○
10D0H (R/W)	Internal memory	Memory01	○	○
10D1H (R/W)		Memory02	○	○
10D2H (R/W)		Memory03	○	○
10D3H (R/W)		Memory04	○	○
10D4H (R/W)		Memory05	○	○
10D5H (R/W)		Memory06	○	○
10D6H (R/W)		Memory07	○	○
10D7H (R/W)		Memory08	○	○
10D8H (R/W)		Memory09	○	○
10D9H (R/W)		Memory10	○	○
10DAH (R/W)		Memory11	○	○
10DBH (R/W)		Memory12	○	○
10DCH (R/W)		Memory13	○	○
10DDH (R/W)		Memory14	○	○
10DEH (R/W)		Memory15	○	○
10DFH (R/W)		Memory16	○	○

1) Trigger 1 action 1000H(W) (RUN mode)

Enter string: 010610000001 E8 Return string: 010610000001 E8

Description: After a "1" is written, the switch is successful if the string returned is identical.

If triggered in Modbus mode, the results are not automatically output but saved in the 1010H–104H registers. You can then read the inspection results after Ready is ON.

Error handling: Return string

- : 01860178 : Incorrect function code (not 06 Write)
- : 01860376 : Incorrect write data length (only one write containing "1" is allowed)
- : 01860475 : Cannot run (incorrect system mode)
- : 01861069 : Incorrect write parity code
- : 01861168 : Cannot run (system is in the Ready state)

2) Trigger 2 action and output 1001H(W) (RUN mode)

Input string: 010610010001 E7 Return string: 010610010001 E7

Description: After a "1" is written, the switch is successful if the string returned is identical.

If triggered in Modbus mode, the results are not automatically output but saved in the 1010H–104H registers. You can then read the inspection results after Ready is ON.

Error handling: Return string

- : 01860178 : Incorrect function code (not 06 Write)
- : 01860376 : Incorrect write data length (only one write containing "1" is allowed)
- : 01860475 : Cannot run (incorrect system mode)
- : 01861069 : Incorrect write parity code
- : 01861168 : Cannot run (system is in the Ready state)

3) Data output 1010H–104FH(R) (RUN mode)

Output the previous inspection result if there is no inspection program to run.

16-bit (Word) format (to return 50,000 and 300):

Input string: 010310100002 DA Return string: 010304C350012CB8

Description: 50,000 is C350 (hex) and 300 is 12C (hex); B8 is the parity code.

32-bit (Double Word) format (to return 400,000 and 300):

Input string: 010310100004 D8 Return string: 01030800061A800000012C27

Description: 400,000 is 61A80 (hex) and 300 is 12C (hex); 27 is the parity code.

- If output value exceeds 65535, select “set data format” to [32 bits] to prevent writing to the wrong register.

Judge (0/1) format (return bit2 = 0, bit3 = 1, bit4 = 1):

Input string: 010310100001 DB Return string: 0103020018E2

Description: 0018(hex) is 0000000000011000(binary)

- Judge output format is [16bits] regardless of the settings ([16bits] or [32bits]).
For example, return data is 400,000 with bit2 = 0, bit3 = 1, bit4 = 1 set of judge.
Read three strings: 010310100003 D9 (one data DW and one judge W)
Returned: 01030600061A8000183E

Error handling: Return string

- : 0183017B : Incorrect function code (not 03 Write)
- : 0183027A : Read length is too long (more than 64)
- : 01830478 : Cannot run (incorrect system mode)
- : 0183106C : Incorrect read parity code

4) Switch to RUN mode 1050H(W) (PROG mode)

Enter string: 010610500001 5A Return string: 010610500001 5A

Description: After a "1" is written, the switch is successful if the string returned is identical.

Error handling: Return string

- : 01860178 : Incorrect function code (not 06 Write)
- : 01860376 : Incorrect write data length (only one write containing "1" is allowed)
- : 01860475 : Cannot run (incorrect system mode)
- : 01861069 : Incorrect write parity code

5) Switch to PROG mode 1051H(W) (RUN mode)

Input string: 010610510001 97 Return string: 010610510001 97

Description: After a "1" is written, the switch is successful if the string returned is identical.

Error handling: Return string

- : 01860178 : Incorrect function code (not 06 Write)
- : 01860376 : Incorrect write data length (only one write containing "1" is allowed)
- : 01860475 : Cannot run (incorrect system mode)
- : 01861069 : Incorrect write parity code

6) Read/switch program ID 1060H(R/W) (RUN mode)

Program ID 0–31 saved on internal memory and 32–255 on SD card.

Read program ID (returns program ID 10):

Input string: 010310600001 8B Return string: 010302000A F0

Description: 10 (dec) is 000A (hex).

Switch program ID (switch to program ID 20):

Enter string: 010610600014 75 Return string: 010610600014 75

Description: 20 (dec) is 0014 (hex).

After the value is written, the switch is successful if the string returned is identical.

Error handling: Return string

- : 0183017B : Incorrect function code (not 03 Read or 06 Write)
- : 0183027A : Read length is too long (length must be 1)
- : 01830478 : Cannot run (incorrect system mode)
- : 0183106C : Incorrect read parity code
- : 01860376 : Incorrect write data length (only one write is allowed)
- : 01861069 : Incorrect write parity code
- : 01861168 : Cannot run (invalid program ID)

7) Read/switch program ID 1062H(R/W) (RUN mode)

Read window ID (returns window ID 50):

Input string: 010310620001 89 Return string: 0103020032 C8

Description: 50 (dec) is 0032 (hex).

Switch window ID: (switch to window ID 30)

Input string: 01061062001E 69 Return string: 01061062001E 69

Description: 30 (dec) is 001E (hex).

After the value is written, the switch is successful if the string returned is identical.

Error handling: Return string

- : 0183017B : Incorrect function code (not 03 Read or 06 Write)
- : 0183027A : Read length is too long (length must be 1)
- : 01830478 : Cannot run (incorrect system mode)
- : 0183106C : Incorrect read parity code
- : 01860376 : Incorrect write data length (only one write is allowed)
- : 01861069 : Incorrect write parity code
- : 01861168 : Cannot run (invalid window ID)

8) Read upper/lower limit (window) 1070H–1075H (RUN mode)

The following six registers are required to read the [Window] upper/lower limits.

1070H (R/W): Read/write data ID

1071H (R/W): Read/write window ID

1072H (R): Read upper limit (Low word)

1073H (R): Read upper limit (High word)

1074H (R): Read lower limit (Low word)

1075H (R): Read lower limit (High word)

- [1070H data ID] and [1071H window ID] are first written to the registers to be accessed, then you can read data from the 1072H–1075H addresses.

Read upper/lower limit (for example, data ID = 2, window ID = 5, upper/lower limits are 500,000 and 300):

First enter string: 0110107000020400020005 62 Return string: 011010700002
6D

Description: 2 (dec) is 0002 (hex).

5 (dec) is 0005 (hex).

Then enter read string: 010310720004 76

Return string: 0103080007A1200000012C FF

Description: 500,000 (dec) is 0007A120 (hex).

300 (dec) is 0000012C (hex).

Upper/lower limits are fixed DW (32 bits) format.

Error handling: Return string

- : 0183017B : Incorrect function code (not 03 Read or 10 Write)
- : 0183027A : Read length is too long (length must less than be 6)
- : 01830478 : Cannot run (incorrect system mode)
- : 0183106C : Incorrect read parity code
- : 01860376 : Incorrect write data length (only one or two writes are allowed)
- : 01860475 : Cannot run (incorrect system mode)
- : 01861069 : Incorrect write parity code
- : 01861168 : Cannot run (invalid data ID or window ID)

9) Write upper/lower limit (window) 1077H–107CH (RUN mode)

The following six registers are required to write the [Window] upper/lower limits. For writing to the upper/lower limits, the six register writes can be issued at the same time.

1077H (W): Write data ID

1078H (W): Write window ID

1079H (W): Write upper limit (Low word)

107AH (W): Write upper limit (High word)

107BH (W): Write lower limit (Low word)

107CH (W): Write lower limit (High word)

Write upper/lower limit: for example, data ID = 6, window ID = 20, upper/lower limits are 600,000 and 400

Input string: 0110107700060C00060014000927C000000190 BB

Return string: 011010770006 62

Description: 6 (dec) is 0006 (hex).

20 (dec) is 0014 (hex).

600,000 (dec) is 000927C0 (hex).

400 (dec) is 00000190 (hex).

Upper/lower limits are fixed DW (32 bits) format.

Error handling: Return string

- : 01860178 : Incorrect function code (not 10 Multi Write)
- : 01860376 : Incorrect write data length (only six writes are allowed)
- : 01860475 : Cannot run (incorrect system mode)
- : 01861069 : Incorrect write parity code
- : 01861168 : Cannot run (invalid data ID or window ID)

10) Read upper/lower limit - calculator 1080H–1084H (RUN mode)

The following five registers are required to read the [Calculator] upper/lower limits.

1080H (R/W): Read/write calculator ID

1081H (R): Read upper limit (Low word)

1082H (R): Read upper limit (High word)

1083H (R): Read lower limit (Low word)

1084H (R): Read lower limit (High word)

- [1080H calculator ID] is first written to the register, then you can read data from the 1081H–1084H addresses.

Read upper/lower limit (for example, calculator ID to read is 5, upper/lower limits are 500,000 and 300):

First enter string: 010610800005 64 Return string: 010610800005 64

Description: 5 (dec) is 0005 (hex).

Then enter read string: 010310810004 67

Return string: 0103080007A1200000012C FF

Description: 500,000 (dec) is 0007A120 (hex).

300 (dec) is 0000012C (hex).

Upper/lower limits are fixed DW (32bits) format.

Error handling: Return string

- : 0183017B : Incorrect function code (not 03 Read or 06 Write)
- : 0183027A : Read length is too long (length must less than be 5)
- : 01830478 : Cannot run (incorrect system mode)
- : 0183106C : Incorrect read parity code
- : 01860376 : Incorrect write data length (only one write is allowed)
- : 01860475 : Cannot run (incorrect system mode)
- : 01861069 : Incorrect write parity code
- : 01861168 : Cannot run (invalid calculator ID)

11) Write upper/lower limit (calculator) 1086H–108AH (RUN mode)

The following five registers are required to write the [Calculator] upper/lower limits. For writing to the upper/lower limits, the five register writes can be issued at the same time.

1086H (W): Write to calculator ID

1087H (W): Write upper limit (Low word)

1088H (W): Write upper limit (High word)

1089H (W): Write lower limit (Low word)

108AH (W): Write lower limit (High word)

Write upper/lower limit (for example, Calculator ID to write is 20, upper/lower limits are 600,000 and 400):

Input string: 0110108600050A0014000927C000000190 B5

Return string: 011010860005 54

Description: 5 (dec) is 0005 (hex).

20 (dec) is 0014 (hex).

600,000 (dec) is 000927C0 (hex).

400 (dec) is 00000190 (hex).

Upper/lower limits are fixed DW (32 bits) format.

Error handling: Return string

- : 01860178 : Incorrect function code (not 10 Multi Write)
- : 01860376 : Incorrect write data length (only five writes are allowed)
- : 01860475 : Cannot run (incorrect system mode)
- : 01861069 : Incorrect write parity code
- : 01861168 : Cannot run (invalid calculator ID)

12) Read/set time and date 1090H–1095H (RUN/PROG mode)

1090H (R/W): Year (00–99, without the thousandth and hundredth digits)

1091H (R/W): Month (01–12)

1092H (R/W): Day (01–31)

1093H (R/W): Hour (00–23)

1094H (R/W): Minute (00–59)

1095H (R/W): Second (00–59)

Read time/date (for example, to read 2011/07/22 08:30:58):

Input string: 010310900006 56

Return string: 01030C000B000700160008001E003A 68

Description: 11 (dec) is 000B (hex).

07 (dec) is 0007 (hex).

22 (dec) is 0016 (hex).

08 (dec) is 0008 (hex).

30 (dec) is 001E (hex).

58 (dec) is 003A (hex).

Write time/date (for example, to write 2011/08/25 12:30:40):

Enter string : 0110109000060C000B00080019000C001E0028 BF

Return string: 011000900006 59

Description: 11 (dec) is 000B (hex).

08 (dec) is 0008 (hex).

25 (dec) is 0019 (hex).

12 (dec) is 000C (hex).

30 (dec) is 001E (hex).

40 (dec) is 0028 (hex).

In addition to multi-writes to the date/time, single write 06 is also supported.

Error handling: Return string

- : 0183017B : Incorrect function code (not 03 Read, 06 Write, or 10 Multi Write)
- : 0183027A : Read length is too long (length must less than be 6)
- : 0183106C : Incorrect read parity code
- : 01860376 : Incorrect write length (length must be 6 for multi write)
- : 01861069 : Incorrect write parity code
- : 01861267 : Cannot run (illegal write data or out of range)

13) Set camera shutter speed 10A0H–10A1H (RUN mode)

The following two registers are required to write [Camera shutter speed]. Both register writes can be issued at the same time with multi-write.

10A0H (W): Camera ID (1–2)

10A1H (W): Shutter speed (1–15)

01 = 1 s	05 = 1/100 s (10 ms)	09 = 1/1000 s (1 ms)	13 = 1/10000 s (0.1 ms)
02 = 1/2 s (500 ms)	06 = 1/120 s (8 ms)	10 = 1/2000 s (0.5 ms)	14 = 1/20000 s (0.05 ms)
03 = 1/15 s (66 ms)	07 = 1/240 s (4 ms)	11 = 1/4000 s (0.25 ms)	15 = custom
04 = 1/30 s (33 ms)	08 = 1/500 s (2 ms)	12 = 1/5000 s (0.2 ms)	

Write settings (for example, set Camera2 shutter speed to 0.5 ms):

Input string: 011010A00002040002000A 2D CR LF

Return string: 011010A00002 3D CR LF

Description: 2 (dec) is 0002 (hex).

10 (dec) is 000A (hex).

Error handling: Return string

- : 01860178 CR LF : Incorrect function code (not 10 Multi Write)
- : 01860376 CR LF : Incorrect write data length (only two writes are allowed)
- : 01860475 CR LF : Cannot run (incorrect system mode)
- : 01861069 CR LF : Incorrect write parity code
- : 01861267 CR LF : Cannot run (illegal write data or out of range)

14) Set camera gain and brightness 10A2H–10A4H (RUN mode)

The following three registers are required to write [Gain and brightness]. The three register writes can be issued at the same time with multi-write.

10A2H (W): Camera ID (1–2)

10A3H (W): Gain (00–99 higher is brighter)

10A4H (W): Brightness (00–99 higher is brighter)

Write settings (for example, set Camera2 gain and brightness to 50 and 70 respectively):

Enter string: 011010A2000306000200320046 BA CR LF

Return string: 011010A20003 3A CR LF

Description: 2 (dec) is 0002 (hex).

50 (dec) is 0032 (hex).

70 (dec) is 0046 (hex).

Error handling: Return string

- : 01860178 CR LF : Incorrect function code (not 10 Multi Write)
- : 01860376 CR LF : Incorrect write data length (only three writes are allowed)
- : 01860475 CR LF : Cannot run (incorrect system mode)
- : 01861069 CR LF : Incorrect write parity code
- : 01861267 CR LF : Cannot run (illegal write data or out of range)

15) Change password 10A5H–10A6H (RUN/PROG mode)

The following two registers are required to change the password. Both register writes can be issued at the same time with multi-write.

10A5H (W): Old password (4 digits)

10A6H (W): New password (4 digits)

Write settings (for example, change the password from 1234 to 5678):

Input string: 011010A500020404D2162E 1A CR LF

Return string: 011010A50002 38 CR LF

Description: 1234 (dec) is 04D2 (hex).

5678 (dec) is 162E (hex).

Error handling: Return string

- : 01860178 CR LF : Incorrect function code (not 10 Multi Write)
- : 01860376 CR LF : Incorrect write data length (only two writes are allowed)
- : 01861069 CR LF : Incorrect write parity code
- : 01861267 CR LF : Cannot run (illegal write data or out of range)
- : 01861366 CR LF : Cannot run (incorrect password)

16) Enable input trigger 10B0H(W) (RUN mode)

Input string: 010610B00001 38 CR LF Return string: 010610B00001 38 CR LF

Description: After a "1" is written, the switch is successful if the string returned is identical.

Error handling: Return string

- : 01860178 CR LF : Incorrect function code (not 06 Write)
- : 01860376 CR LF : Incorrect write data length (only one write containing "1" is allowed)
- : 01860475 CR LF : Cannot run (incorrect system mode)
- : 01861069 CR LF : Incorrect write parity code

17) Disable input trigger 10B1H(W) (RUN mode)

Input string: 010610B10001 37 CR LF Return string: 010610B10001 37 CR LF

Description: After a "1" is written, the switch is successful if the string returned is identical.

Error handling: Return string

- : 01860178 CR LF : Incorrect function code (not 06 Write)
- : 01860376 CR LF : Incorrect write data length (only one write containing "1" is allowed)
- : 01860475 CR LF : Cannot run (incorrect system mode)
- : 01861069 CR LF : Incorrect write parity code

18) Save all project settings 10B2H(W) (program mode)

Input string: 010610B20001 36 CR LF Return string: 010610B20001 36 CR LF

Description: After a "1" is written, the switch is successful if the string returned is identical.

Error handling: Return string

- : 01860178 CR LF : Incorrect function code (not 06 Write)
- : 01860376 CR LF : Incorrect write data length (only one write containing "1" is allowed)
- : 01860475 CR LF : Cannot run (incorrect system mode)
- : 01861069 CR LF : Incorrect write parity code

19) Capture image 10B3H(W) (RUN/PROG mode)

Input string: 010610B30001 35 CR LF Return string: 010610B30001 35 CR LF

Description: After a "1" is written, the switch is successful if the string returned is identical.

Error handling: Return string

- : 01860178 CR LF : Incorrect function code (not 06 Write)
- : 01860376 CR LF : Incorrect write data length (only one write containing "1" is allowed)
- : 01861069 CR LF : Incorrect write parity code

20) Clear statistics 10B4H(W) (RUN/PROG mode)

Input string: 010610B40001 34 CR LF Return string: 010610B40001 34 CR LF

Description: After a "1" is written, the switch is successful if the string returned is identical.

Error handling: Return string

- : 01860178 CR LF : Incorrect function code (not 06 Write)
- : 01860376 CR LF : Incorrect write data length (only one write containing "1" is allowed)
- : 01861069 CR LF : Incorrect write parity code

21) Reset system 10B5H(W) (RUN mode)

Input string: 010610B50001 33 Return string: 010610B50001 33

Description: After a "1" is written, the switch is successful if the string returned is identical.

Error handling: Return string

- : 01860178 : Incorrect function code (not 06 Write)
- : 01860376 : Incorrect write data length (only one write containing "1" is allowed)
- : 01860475 : Cannot run (incorrect system mode)
- : 01861069 : Incorrect write parity code

22) Simulate keypad input 10C0H(W) (RUN/PROG mode)

Single write (1–11) value as below.

01 = Up	05 = ENTER	09 = FUNCTION
02 = Down	06 = RUN/STOP	10 = DISPLAY
03 = Right	07 = ESC	11 = CUSTOM
04 = Left	08 = TRIGGER	

For example, write 10 to the register to communicate the [Display] keypad command:

Input string: 010610C0000A 1F Return string: 010610C0000A 1F

Description: 10 (dec) is 000A (hex).

Error handling: Return string

- : 01860178 : Incorrect function code (not 06 Write)
- : 01860376 : Incorrect write data length (only one write is allowed)
- : 01861069 : Incorrect write parity code

9.5 RS232 pin definitions

The DMV1000 can directly connect to the PC master while in slave mode.

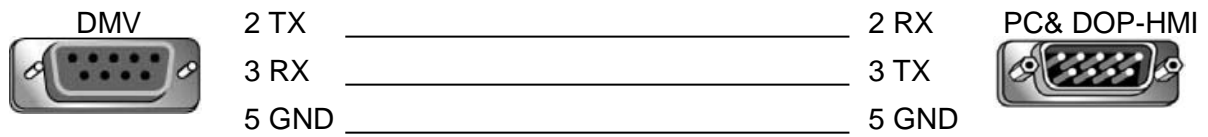

Note that RX and TX must be reversed between the DMV1000 and the PLC as both are configured to connect in slave modes.

To achieve normal operations when connecting the DMV1000 (RS232) to PLC RS485, in addition to using the RS232-to-RS485 adapter, you must reverse RX and TX.

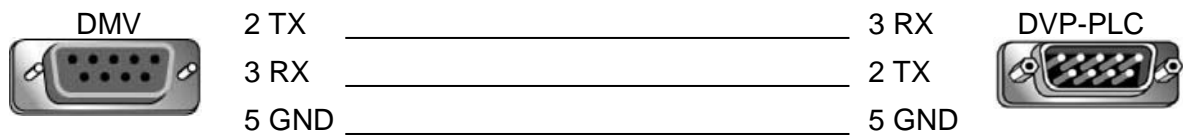

9.6 ASCII Table:

The characters in **bold** are currently used by DMV1000 (HEX is hexadecimal).

HEX	ASCII	HEX	ASCII	HEX	ASCII	HEX	ASCII
0	NUL	20	SPACE	40	@	60	`
1	SOH	21	!	41	A	61	a
2	STX	22	"	42	B	62	b
3	ETX	23	#	43	C	63	c
4	EOT	24	\$	44	D	64	d
5	ENQ	25	%	45	E	65	e
6	ACK	26	&	46	F	66	f
7	BEL	27	'	47	G	67	g
8	BS	28	(48	H	68	h
9	TAB	29)	49	I	69	i
A	LF	2A	*	4A	J	6A	j
B	VT	2B	+	4B	K	6B	k
C	FF	2C	,	4C	L	6C	l
D	CR	2D	-	4D	M	6D	m
E	SO	2E	.	4E	N	6E	n
F	SI	2F	/	4F	O	6F	o
10	DLE	30	0	50	P	70	p
11	DC1	31	1	51	Q	71	q
12	DC2	32	2	52	R	72	r
13	DC3	33	3	53	S	73	s
14	DC4	34	4	54	T	74	t
15	NAK	35	5	55	U	75	u
16	SYN	36	6	56	V	76	v
17	ETB	37	7	57	W	77	w
18	CAN	38	8	58	X	78	x
19	EM	39	9	59	Y	79	y
1A	SUB	3A	:	5A	Z	7A	z
1B	ESC	3B	;	5B	[7B	{
1C	FS	3C	<	5C	\	7C	
1D	GS	3D	=	5D]	7D	}
1E	RS	3E	>	5E	^	7E	~
1F	US	3F	?	5F	_	7F	DEL

9.7 Communication formatting

The DMV1000 communicates in ASCII format, therefore the ASCII data must be converted to decimal for HMI and PLC. The example below applies to the Delta HMI (DOP series) and PLC (DVP series). When using an HMI or PLC from other suppliers, this protocol conversion format can be referenced. Follow the directions provided from these suppliers to complete the process.

9.7.1 Delta HMI (DOP) data conversion

For example: DMV output result: T012340555 CR (data length set at 4).

T0 begins result TX, 1234 is the first data, 0555 is the second data, and CR is the suffix.

1) Use INITCOM to set HMI port parameters.

Command ▾	INITCOM	➔	COM Port	COM1
Variable 1	\$10		Interface	RS232
Variable 2	0, 0, 0, 2, 0, 6, 0		Data Bits	7 Bits
Variable 3	Var3		Parity	Even
Variable 4	Var4		Stop Bits	1 Bits
			Baud Rate	9600
			Flow Control	No Flow Control

2) Use SELECTCOM to set TX port. (0 for COM1 and 1 for COM2)

Command ▾	SELECTCOM
Variable 1	0
Variable 2	Var2

4) Use PUTCHARS for TX string.

Variable1: TX status (0 for failed and 1 for success)

Variable2: TX start address

Variable3: TX string length (variable, where one character represents one length)

Variable4: Timeout (or variable, unit: milliseconds)

Command ▾	PUTCHARS
Variable 1	\$20
Variable 2	\$21
Variable 3	4
Variable 4	300

Chapter 9: Serial Communication

5) Use GETCHARS for RX.

Variable1: RX status (0 for failed and 1 for success)

Variable2: RX start address

Variable3: RX string length (variable, where one character represents one length)

Variable4: RX timeout (or variable, unit: milliseconds)

Command	GETCHARS
Variable 1	\$30
Variable 2	\$31
Variable 3	10
Variable 4	300

6) As above, RX string is saved at \$31. In the following example for a string T012340555, it is converted into the decimal results 1234 and 555 then saved to the register.

- Use B2W to save each character into a register.

Command	B2W
Variable 1	\$200
Variable 2	\$31
Variable 3	10
Variable 4	Var4

Register	HEX	Register	HEX
\$200	54 (T)	\$205	34 (4)
\$201	30 (0)	\$206	30 (0)
\$202	31 (1)	\$207	35 (5)
\$203	32 (2)	\$208	35 (5)
\$204	33 (3)	\$209	35 (5)

- Use A2H to convert register characters into a register.

Command	A2H
Variable 1	\$300
Variable 2	\$202

Register	Hexadecimal
\$300	1234
\$301	0555

Command	A2H
Variable 1	\$301
Variable 2	\$206

- Use BIN to convert hexadecimal into decimal for each register.

Command	BIN
Variable 1	\$400
Variable 2	\$300

Register	Decimal
\$400	1234
\$401	0555

Command	BIN
Variable 1	\$401
Variable 2	\$301

7) A2H applies to four-character numbers. Please adhere to the following for other than four-character numbers.

- Fewer than four characters:
 - ◆ For example: To extract 34 from \$400 = 1234
Divide by 100 using [Take remainder] to get 34.
 - ◆ For example: To extract 123 from \$400 = 1234
Use [Divide] to divide by 10 and take the quotient (123).
- More than four characters:
 - ◆ For example: To extract 12340555 from \$400 = 1234 and \$401 = 555
[Multiply] \$400 = 1234 by 10000 and then add 555 to get 12340555.
 - ◆ For example: To extract 340555 from \$400 = 1234 and \$401 = 555
Divide the numerical value \$400 = 1234 by 100 using [Take remainder] to get 34.
Then [Multiply] 34 by 10000 and then add 555 to get 340555.
 - ◆ For example: To extract 123405 from \$400 = 1234 and \$401 = 555
[Divide] \$401 = 555 by 100 and take the quotient to get 05.
Then [Multiply] \$400 = 1234 by 100 and then add 05 to get 123405.

9.7.2 Delta PLC (DVP) data conversion

For example: DMV output result: T012340555 CR (data length set at 4).

T0 begins result TX, 1234 is the first data, 0555 is the second data, and CR is the suffix.

1) Set PLC protocol and timeout.

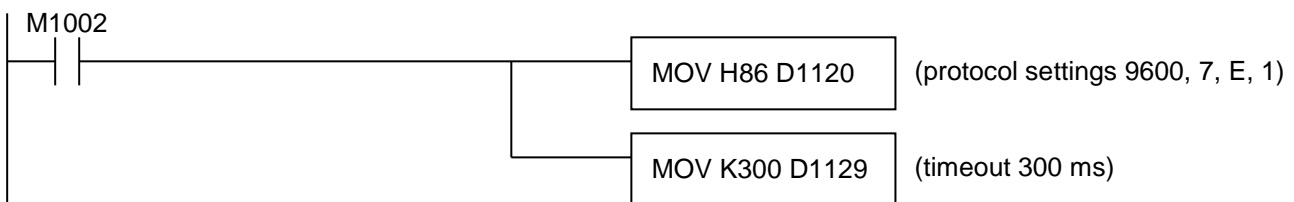

2) Use RS to receive 11 characters including the CR suffix. (for example, M0 as the trigger flag)

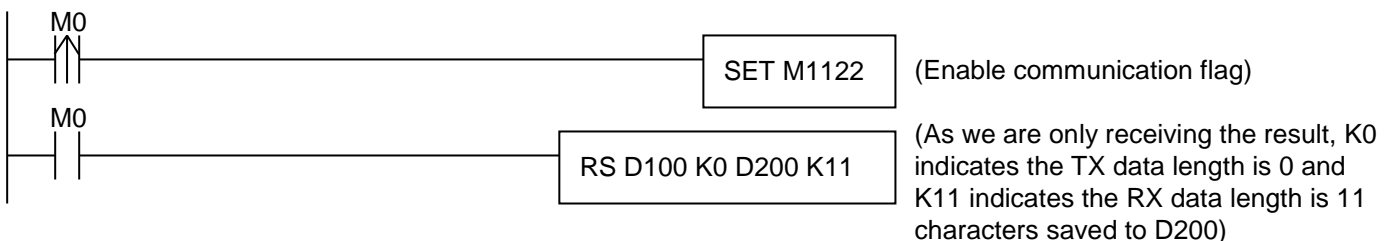

3) Examine the contents of D200–D205 (6 registers).

Register	Hexadecimal	Register	Hexadecimal
D200	H3054 (0T)	D203	H3530 (50)
D201	H3231 (21)	D204	H3535 (55)
D202	H3433 (43)	D205	HD CR

4) Use M1123 flag (RX done) to convert data.

- HEX D201 D300 K4
- HEX D203 D301 K4
- M1123
- Use HEX to combine and save the string (as hexadecimal) to the register.

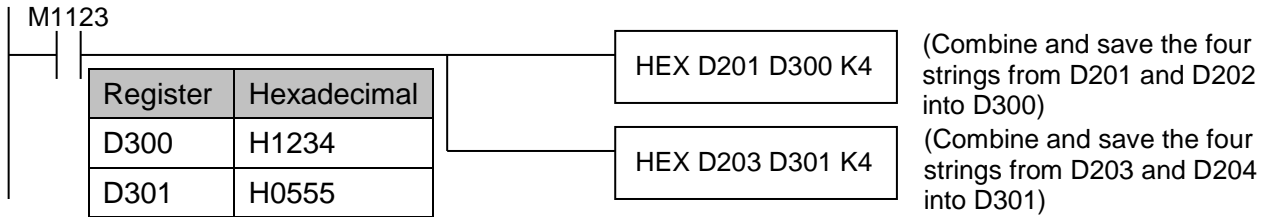

- Combine and save the string (as hexadecimal) to the register.

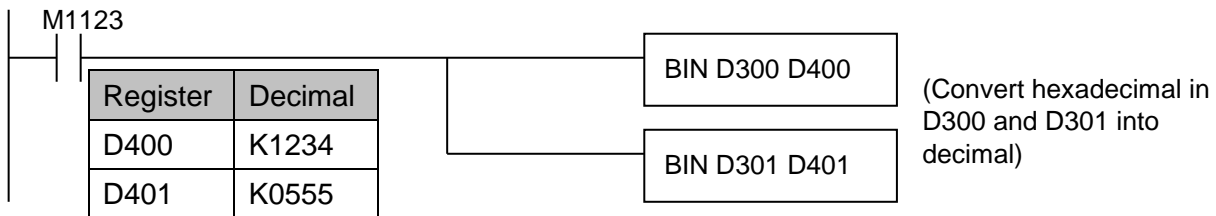

5) HEX applies to four-character numbers. Please adhere to the following for other than four-character numbers.

- Fewer than four characters:
 - ◆ For example: To extract 34 from D400 = 1234
[Divide] by 100 and take the quotient to get 34.
 - ◆ For example: To extract 123 from D400 = 1234
Use [Divide] to divide by 10 and take the quotient (123).
- More than four characters:
 - ◆ For example: To extract 12340555 from D400 = 1234 and D401 = 555
[Multiply] D400 = 1234 by 10000 and then add 555 to get 12340555.
 - ◆ For example: To extract 340555 from D400 = 1234 and D401 = 555
[Divide] D400 = 1234 by 100 and take the remainder to get 34.
Then [Multiply] 34 by 10000 and then add 555 to get 340555.
 - ◆ For example: To extract 123405 from D400=1234 and D401 = 555
[Divide] D401 = 555 by 100 and take the quotient to get 05.
Then [Multiply] D400 = 1234 by 100 and then add 05 to get 123405.

Remark The HEX command in the DVP1000 PLC supports 1–16 characters. Refer to the PLC operating manual for more information.

Chapter 10

Ethernet Communication Commands

10.1 Ethernet Communication Method

In the Ethernet, the system communicates with the master computer using the MODBUS TCP protocol. The controller will put inspection results in specific MODBUS addresses. A master computer (such as PLC device) will be needed to send the MODBUS TCP read command to read inspection results. (please refer to Section 9.5.3 for more information about the MODBUS command format)

10.2 Description of MODBUS TCP Communication Method

■ Set the DMV IP Address

Configure the DMV IP address in [System] > [Communications] > [Ethernet].

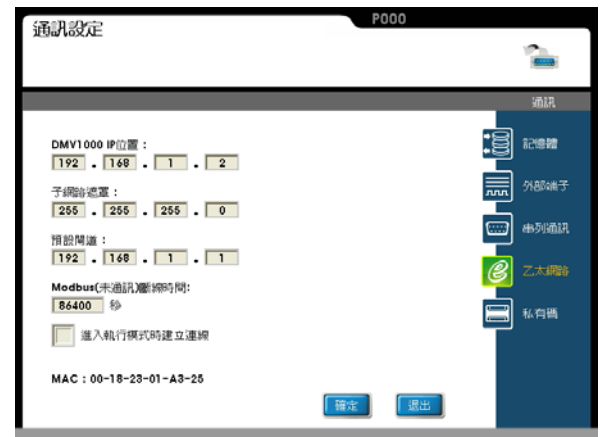

■ Output format

Drag the detection result into the output queue in [Program] > [Output] > [Ethernet]. This way the first detection result will be placed in the MODBUS TCP address 1010H, the second detection result will be placed in the MODBUS TCP address 1012H...

Reference Refer to Section 9.5.3 Slave Mode Instruction Set for MODBUS instructions

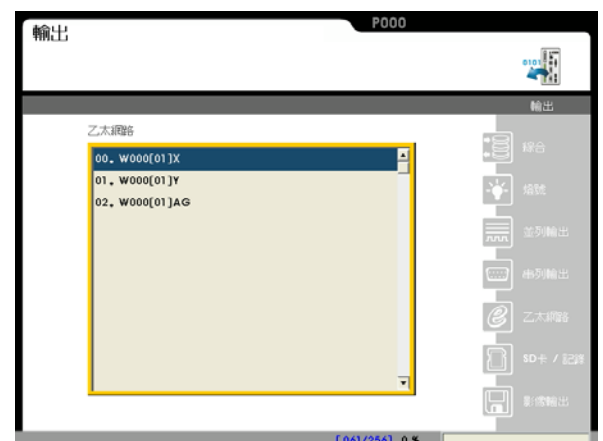

10.3 MODBUS TCP Communication Commands

Refer to 9.5.3 Table 4 for the system's MODBUS communication addresses.

Where R is the Read command (03 code up to 64 reads)

W is the Write command (single write: 06 code; multiple writes: 10 code up to 6 writes).

Read 03 command: (read single or multiple data controlled by the [Byte] parameter)

Output format:

00 0A	00 00	00 06	01	03	10 10	00 06
Send ID	Protocol ID	Bytes	Node ID	Function code	Function address	Length

Return format:

00 0A	00 00	00 0F	01	03	0C	00 01 00 00	00 02 00 00	00 03 00 00
Send ID	Protocol ID	Bytes	Node ID	Function code	Data Bytes	Data 1 (32bit)	Data 2 (32bit)	Data 3 (32bit)

Write 06 single data: (the correctly written data string is returned as is)

Output format:

00 0B	00 00	00 06	01	06	10 00	00 01
Send ID	Protocol ID	Bytes	Node ID	Function code	Function address	Write value

Return format:

00 0B	00 00	00 06	01	06	10 00	00 01
Send ID	Protocol ID	Bytes	Node ID	Function code	Function address	Write value

Write 10 multiple data: (up to 6 writes)

Output format:

00 0C	00 00	00 0B	01	10	10 D0	00 02	04	00 01 00 02
Send ID	Protocol ID	Bytes	Node ID	Function code	Function address	Write length	Number of bytes written	Data (32bit)

Return format:

00 0C	00 00	00 06	01	10	10 D0	00 02
Send ID	Protocol ID	Bytes	Node ID	Function code	Function address	Write length

1) Trigger 1 action 1000H(W) (RUN Mode Enabled)

Input Packet 00 00 00 00 00 06 01 06 10 00 00 01

Return Packet 00 00 00 00 00 06 01 06 10 00 00 01

Description: After a "1" is written, the switch is successful if the string returned is identical.

2) Trigger 2 action 1001H(W) (RUN Mode Enabled)

Input Packet 00 00 00 00 00 06 01 06 10 01 00 01

Return Packet 00 00 00 00 00 06 01 06 10 01 00 01

Description: After a "1" is written, the switch is successful if the string returned is identical.

3) Reading Inspection Result 1010H - 104FH(R) (RUN Mode Enabled)

Input Packet 00 00 00 00 00 06 01 03 10 10 00 04

Return Packet 00 00 00 00 00 0B 01 03 08 30 39 00 00 09 32 00 01

Description: Inspection Result 1 is 00 00 30 39H or 12345 in the decimal number system.

Inspection Result 2 is 00 01 09 32H or 67890 in the decimal number system.

4) Reading Judge Result 1010H - 104FH(R) (RUN Mode Enabled)

Input Packet 00 00 00 00 00 06 01 03 10 10 00 01

Return Packet 00 00 00 00 00 05 01 03 02 00 05

Description: Where 00 05 is the Judge result indicates that bit 0 is 1 (OK), bit 1 is 0 (NG), and bit 2 is 1 (OK).

5) Switch to RUN mode 1050H(W) (EDIT mode enabled)

Input Packet 00 00 00 00 00 06 01 06 10 50 00 01

Return Packet 00 00 00 00 00 06 01 06 10 50 00 01

Description: After a "1" is written, the switch is successful if the string returned is identical.

6) Switch to EDIT mode 1051H(W) (RUN mode enabled)

Input Packet 00 00 00 00 00 06 01 06 10 51 00 01

Return Packet 00 00 00 00 00 06 01 06 10 51 00 01

Description: After a "1" is written, the switch is successful if the string returned is identical.

7) Read/switch program ID 1060H(R/W) (RUN, EDIT mode enabled)

Program ID 0 - 31 saved on internal memory and 32 - 999 on SD card.

Read program ID: (returns program ID 10)

Input string 00 00 00 00 00 06 01 03 10 60 00 01

Return string 00 00 00 00 00 05 01 03 02 00 0A

Description: 10(dec) is 000A(hex).

Switch program ID: (switch to program ID 20)

Input string 00 00 00 00 00 06 01 06 10 60 00 14

Return string 00 00 00 00 00 06 01 06 10 60 00 14

Description: 20(dec) is 0014(hex).

After the value is written, the switch is successful if the string returned is identical.

8) Read/switch window ID 1062H(R/W) (RUN Mode Enabled)

Read window ID: (returns window ID 3)

Input string 00 00 00 00 00 06 01 03 10 62 00 01

Return string 00 00 00 00 00 05 01 03 02 00 03

Switch window ID: (switch to window ID 2)

Input string 00 00 00 00 00 06 01 06 10 62 00 02

Return string 00 00 00 00 00 06 01 06 10 62 00 02

Description: After the value is written, the switch is successful if the string returned is identical.

9) Read/set date and time 1090H - 1095H (RUN, EDIT mode enabled)

1090H (R/W) – Year (00 - 99)
 1091H (R/W) – Month (01 - 12)
 1092H (R/W) – Day (01 - 31)
 1093H (R/W) – Hour (00 - 23)
 1094H (R/W) – Minute (00 - 59)
 1095H (R/W) – Second (00 - 59)

Read time/date: (for example, to read 2018/12/27 13:37:50)

Input string 00 00 00 00 00 06 01 03 10 90 00 06
 Return string 00 00 00 00 00 0F 01 03 0C 00 12 00 0C 00 1B 00 0D 00 25 00 32

Description: 18(dec) is 0012(hex).
 12(dec) is 000C(hex).
 27(dec) is 001B(hex).
 13(dec) is 000D(hex).
 37(dec) is 0025(hex).
 50(dec) is 0032(hex).

Write time/date: (for example, to write 2019/01/02 03:04:05)

Input string 00 00 00 00 00 13 01 10 10 90 00 06 0C 00 13 00 01 00 02 00 03 00 04 00 05
 Return string 00 00 00 00 00 06 01 10 10 90 00 06

Description: In addition to multi writes to the date/time, single write 06 is also supported.

10) Enable input trigger 10B0H(W) (RUN Mode Enabled)

Input string 00 00 00 00 00 06 01 06 10 B0 00 01
 Return string 00 00 00 00 00 06 01 06 10 B0 00 01

Description: After writing the numeric value "1", the switch is successful if the string returned is identical.

11) Disable input trigger 10B1H(W) (RUN Mode Enabled)

Input string 00 00 00 00 00 06 01 06 10 B1 00 01
 Return string 00 00 00 00 00 06 01 06 10 B1 00 01

Description: After writing the numeric value "1", the switch is successful if the string returned is identical.

12) Clear statistics 10B4H(W) (RUN/EDIT mode enabled)

Input string 00 00 00 00 00 06 01 06 10 B4 00 01
 Return string 00 00 00 00 00 06 01 06 10 B4 00 01

Description: After writing the numeric value "1", statistics data is successfully cleared if the string returned is identical.

13) Simulate keypad input 10C0H(W) (RUN, EDIT mode enabled)

Single write (1 - 11) value as below.

01= Up	05= ENTER	09= FUNCTION
02= Down	06= RUN/STOP	10= DISPLAY
03= Right	07= ESC	11= CUSTOM
04= Left	08= TRIGGER	

For example, please write 5 to the register to communicate the [ENTER] keypad command.

Input string 00 00 00 00 00 06 01 06 10 C0 00 05

Return string 00 00 00 00 00 06 01 06 10 C0 00 05

Description: After writing the corresponding numeric value, statistics data is successfully cleared if the string returned is identical.

14) Switch Group Number for Trigger Select 10C1H(W) (RUN, EDIT mode enabled)

Input string 00 00 00 00 00 06 01 06 10 C1 00 00

Return string 00 00 00 00 00 06 01 06 10 C1 00 00

Description: After a "0" is written, the system will switch to Group 1. The switch is successful if the string returned is identical.

15) Read/Write Memory 10D0H - 10EFH(W) (RUN, EDIT mode enabled)

The system provides memory areas 10D0H-10EFH (32 words in total) for users to use.

If the memory area that needs to be read is 10D0H and assuming that the data in the memory is 50000.

Input string 00 00 00 00 00 06 01 03 10 D0 00 01

Return string 00 00 00 00 00 05 01 03 02 C3 50

Description: 50,000(dec) is C350(hex).

If the memory area that needs to be read is 10D0H and assuming that the data in the memory is 500000 (DW).

Input string 00 00 00 00 00 06 01 03 10 D0 00 02

Return string 00 00 00 00 00 07 01 03 04 A1 20 00 07

Description: 500,000(dec) is 07A120(hex).

If the memory area that needs to be written is 10D0H and assuming that the data that needs to be written is 50000.

Input string 00 00 00 00 00 06 01 06 10 D0 C3 50

Return string 00 00 00 00 00 06 01 06 10 D0 C3 50

Description: 50,000(dec) is C350(hex). "1" is written and write data is successful if the string returned is identical.

16) Read Window Parameter 10F0H - 10F1H(W) 10F2H - 10F3H(R) (RUN Mode Enabled)

The following 4 registers must be used to read the configured value of [Parameter].

10F0H (W) – Item number to read

10F1H (W) – Window ID to read

10F2H (R) – Window parameter to read (Low word)

10F3H (R) – Window parameter to read (High word)

The data to be accessed, [10F0H data ID] and [10F1H window ID], are written to the register, then the required data can be accessed from the addresses 10F2H - 10F3H.

Read the [Similarity] configured value in [Shape Comparison]: (for example, read the [Similarity] setting in W010 [Shape Comparison], the value is 80)

First enter string 00 00 00 00 00 0B 01 10 10 F0 00 02 04 00 01 00 0A

Return string 00 00 00 00 00 06 01 10 10 F0 00 02

Description: [Similarity] is the second item, so the value "1" (starts from 0) is written into 10F0H, the [Shape Comparison] to be read is in W010, so the value 10 is written into 10F1H.

Input string again 00 00 00 00 00 06 01 03 10 F2 00 02

Return string 00 00 00 00 00 07 01 03 04 00 50 00 00

Description: 80(dec) is 0050(hex) fixed in the DW (32bits) data structure.

17) Write Window Parameter 10F7H - 10FAH(W) (RUN Mode Enabled)

The following 4 registers must be used to write the configured value of [Parameter]. Through multiple entries of write commands, 4 entries of numeric values can be simultaneously written to the register to complete modifying the upper and lower limits.

10F7H (W) – Item number to write

10F8H (W) – Window ID to write

10F9H (W) – Window parameter to write (Low word)

10FAH (W) – Window parameter to write (High word)

[10F7H data ID] and [10F8H window ID] must first be written into the register, and then the [Parameter] configured values can be written into 10F9H-10FAH.

Configured value written into [Edge Strength] in [Position]: (for example, write W001; the [Edge Strength] parameter of [Position] is 20.)

First enter string 00 00 00 00 00 0B 01 10 10 F7 00 02 04 00 02 00 01

Return string 00 00 00 00 00 06 01 10 10 F7 00 02

Description: [Edge Strength] is the third item, so the value "2" (starts from 0) is written into 10F7H, the [Position] to be read is in W001, so the value 1 is written into 10F8H.

Input string again 00 00 00 00 00 0B 01 10 10 F9 00 02 04 00 14 00 00

Return string 00 00 00 00 00 06 01 10 10 F9 00 02

Description: 20(dec) is 0014(hex) fixed in the DW (32bits) data structure.

10.4 Ethernet Communication Example

The following contents mainly describe how to use Delta Electronics' HMI and PLC (AS system) to read detection results through the Ethernet and DMV.

10.4.1 DMV1000

The DMV1000 needs to be configured as follows to use the Ethernet for communication with the DMV1000.

- 1) Configure the DMV IP address in system, communications, Ethernet.
- 2) Go to [Program] > [Output] > [Ethernet] and add detection parameters to output. After adding, the first detection result will be placed in address 1010H, the second detection result will be placed in address 1012H, and the third detection result will be placed in address 1014H.



10.4.2 Delta HMI (DOP)

Make sure to select an HMI model with an Ethernet interface, configuration steps are as follows:

- 1) Enter Options to configure communication parameters, and carry out configuration according to the figure below.
 - A. Select [Ethernet]
 - B. Select [Device]
 - C. Set the type of controller as [MODBUS TCP/IP]
 - D. Define the DMV IP address

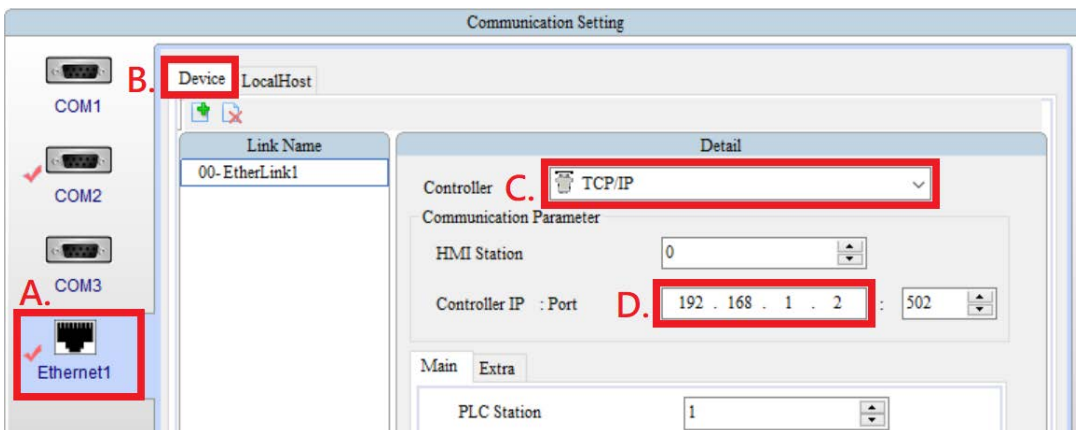

- E. Select [Main Unit]
- F. Define the HMI IP address

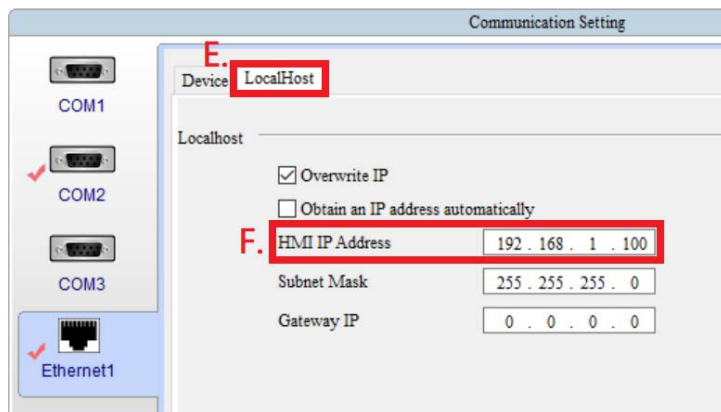

- 2) Return to Screen Editing and configure according to the figure below.
 - A. Create a [Add Constant button] component, and write into address 1000H; write the constant "1" for detection triggering.
 - B. Create a [Display value] component, and write into address 1010H; the format is DW and can be used to read the first detection result.
 - C. If necessary, an additional [Display value] component can be configured, the address configured is 1012H and the second detection result is read.

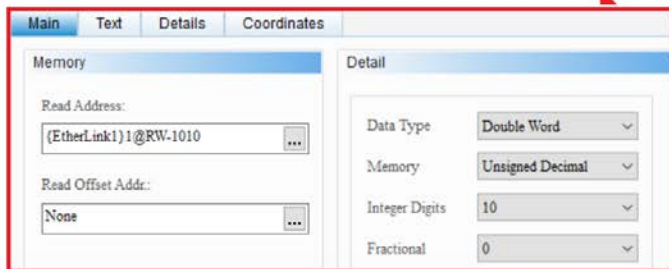
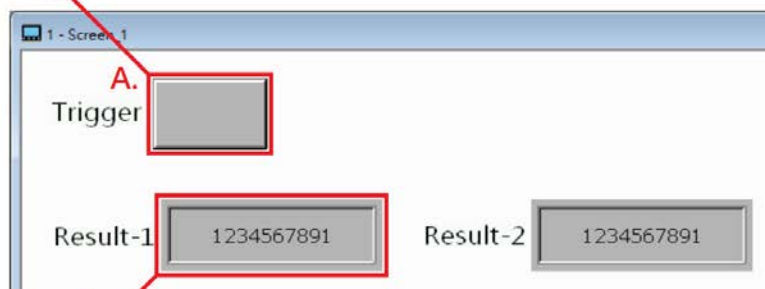
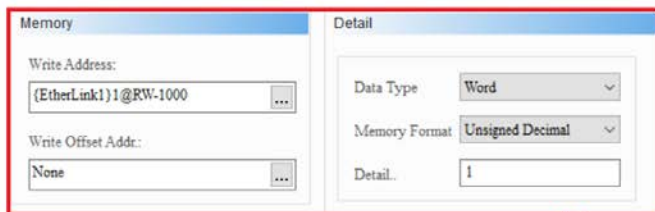

- 3) After completing the configuration above, click on the button on the HMI screen to trigger, and the corresponding detection result can be viewed on the Display Value component.

10.4.3 Delta PLC (AS)

The Delta AS300 series PLC supports data exchange through Ethernet and MODBUS TCP/IP, and transfers DMV1000 detection results to the D register on the PLC. The configuration method is as follows:

- 1) Enter project manager, HWCONFIG, select the corresponding AS main unit to enter the device setup page shown in the figure below.
 - A. Select data exchange - Ethernet.
 - B. Click on [Add] to add a data exchange group.
 - C. Set the condition for executing data exchange. Execute Conditions that can be configured based on requirements include Program Controlled, PLC Execute, and Always Execute.

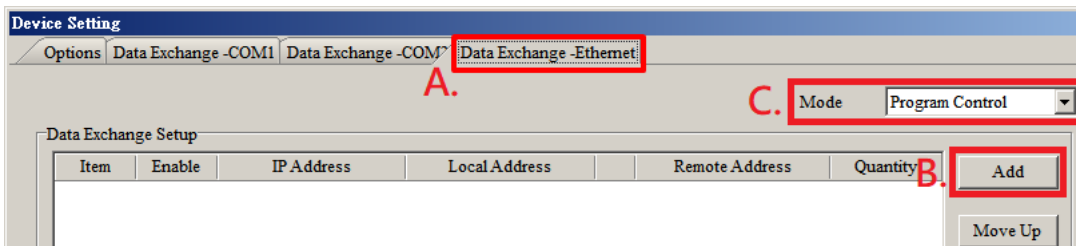

- 2) Enter the data exchange configuration page, as shown in the figure below. Follow the steps below for configuration.
 - A. Enable the data exchange function.
 - B. Set the appropriate data exchange interval and communication timeout.
 - C. Set the DMV IP Address.
 - D. Set device type to MODBUS TCP.
 - E. Set read address to 1010H.
 - F. Set the PLC register for storing data.
 - G. Set the length of data exchange.

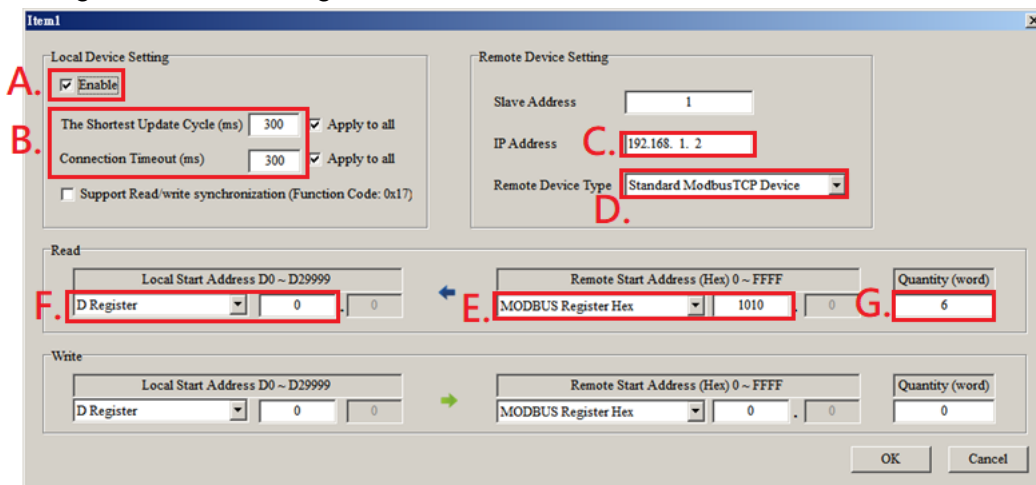

- 3) After configuration is complete, download HWCONFIG to complete AS300 data exchange configuration.

The first DMV detection result can be observed in PLC register D0, the second DMV detection result can be observed in PLC register D2, and the third DMV detection result can be observed in PLC register D4.

Chapter 11

Appendix





11.1 Pre-processing

11.1.1 What is Pre-processing?



You can improve the original captured image with software pre-processing filters built into the controller. You can change the original image first by softening, detecting edges, blurring, and so on to assist in subsequent inspection cycles. The DMV1000 currently supports 12 pre-processing filters with six custom slots for a single inspection cycle. The following section describes the pre-processing filter characteristics and common combinations.

11.1.2 Pre-processing Functions

The following table describes the 12 pre-processing filters.

Serial No.	Function	Description
	None	No pre-processing
1	Gray Cut	Convert grayscale into black or white pixels.  
2	Dilation	Dilation (expand) the white pixels  
3	Erosion	Shrink the white pixels.

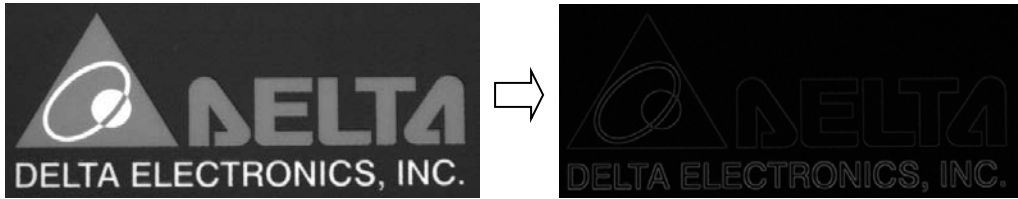
		  
4	Average	<p>Take the average with surrounding pixels to blur the image and reduce noise.</p>   
5	Median	<p>Take the median with surrounding pixels to reduce noise without blurring the image.</p>   
6	Sharpen	<p>Strengthen the contrast of edge transitions in the grayscale image; the overall grayscale level decreases.</p>   
7	Sobel X	<p>Extract edges in the X direction.</p>   
8	Sobel Y	<p>Extract edges in the Y direction.</p>   

9	Sobel	<p>Extract edges in the XY directions.</p>  <p>The image shows the Sobel edge detection result for the Delta Electronics logo. The original logo is on the left, and the edge-detected version is on the right, showing thick white edges on a black background.</p>
10	Prewitt	<p>Extract edges in the XY direction with similar effects to Sobel.</p>  <p>The image shows the Prewitt edge detection result for the Delta Electronics logo. The original logo is on the left, and the edge-detected version is on the right, showing thick white edges on a black background.</p>
11	Roberts	<p>Extract edges in the XY direction with similar effects to Sobel, but the edge lines are fainter.</p>  <p>The image shows the Roberts edge detection result for the Delta Electronics logo. The original logo is on the left, and the edge-detected version is on the right, showing thin white edges on a black background.</p>
12	Laplacian	<p>Extract edges in the XY direction with similar effects to Sobel, but the lines are thinner with stronger results at high contrasting edges.</p>  <p>The image shows the Laplacian edge detection result for the Delta Electronics logo. The original logo is on the left, and the edge-detected version is on the right, showing very thin white edges on a black background.</p>
13	Subtract	

■ Composite pre-processing

Each inspection window supports up to six pre-processing combinations. As shown to the right, the system applies pre-processing filters [Erosion], [Dilation], and [Median] to the image in order.

The processed result updates immediately when you select each pre-processing function.



■ Upper right (show all) function

✧ Selected: Use three pre-processing filters as shown to the right.

Regardless of where the Target window is located, the final image shows with the three applied pre-processing filters.

✧ Cleared: Show image inside the Target window. As shown to the right, [Filter 3] shows the final processed result from pre-processing 1+2+3. [Filter 2] shows the processed result from pre-processing 1+2. You can move the Target window around to inspect the results of pre-processing filters on different layers beforehand.

■ **Repetition and mask 3*3 (5*5) selection**





You can edit the repetition and mask parameters for each pre-processing filter.

- ✧ For example, to apply the [Erosion] filter twice, set the repetition count to 2 (instead of setting two individual [Erosion] filters back-to-back).
- ✧ Setting the mask parameter to work on 5*5 pixels achieves more distinct results than 3*3.

	Gray Cut	Dilation	Erosion	Average	Median	Sharpen
Repetition		⊙	⊙	⊙	⊙	⊙
Mask		⊙	⊙			

	Sobel X	Sobel Y	Sobel	Prewitt	Roberts	Laplacian	Subtract
Repetition	⊙	⊙	⊙	⊙	⊙	⊙	⊙
Capture							⊙

■ **Example of composite pre-processing**

Steps	Filtered image	Description
1 (original image)		This is the original image. Follow the steps below to filter out the noise and retrieve the clear text from the image.
2 (Dilation)		Use [Dilation] (white spreading) to remove the smaller dark noise. Note that it also reduces the black text.
3 (Dilation) + (Erosion)		Use [Erosion] (eroding into the white) after [Dilation] to restore the black text.
4 (Dilation) + (Erosion) + (Gray Cut)		Use [Gray Cut] on the noiseless image to retrieve the clear text image.

■ Gray Cut instructions



The Gray Cut pre-processing filter quantizes the grayscale levels into either black or white.

If a grayscale pixel falls between two threshold grayscale levels, the pixel is set to white (grayscale 255). If a grayscale pixel falls outside (less than lower bound or higher than upper bound) the two threshold grayscale levels, the pixel is set to black (grayscale 0).

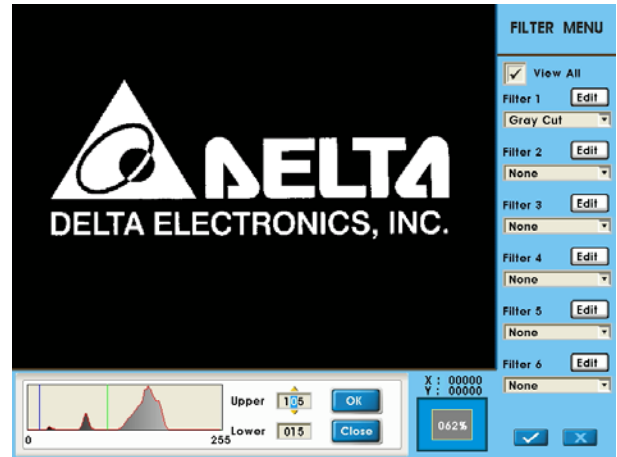
The grayscale histogram displays in the lower-left when using the Gray Cut filter. You can instantly see the Gray Cut results on the display by adjusting the [Upper bound] and [Lower bound] values.

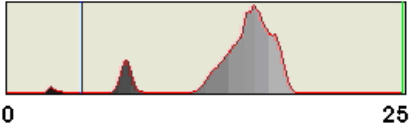

	Resulting image	Grayscale histogram and parameters
Original image		
Description:	<p>There are three grayscale levels in the original image.</p> <ol style="list-style-type: none"> 1) Background color: Lightest grayscale level (closest to 255) 2) Logo color: Medium grayscale level 3) Text color: Darkest grayscale level (closest to 0) <p>The grayscale histogram displays three major distributions of pixels, with the largest block of the pixels in the background color.</p>	
Delete background		
Description:	<p>Keep the upper bound at 255 and set the lower bound to 108. Now that the background grayscale pixels are between the two thresholds (white), removing the background to give emphasis to the logo and text.</p>	

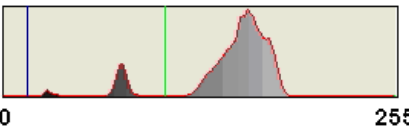
Keep text		 Upper <input type="text" value="255"/> Lower <input type="text" value="48"/>
Description: Keep the upper bound at 255 and set the lower bound to 48. Now that the logo grayscale pixels are between the two thresholds (white), removing the logo to give emphasis to the text.		
Invert image		 Upper <input type="text" value="105"/> Lower <input type="text" value="15"/>
Description: Set the upper bound to 105 and the lower bound to 15. Now that the logo and text grayscale pixels are between the two thresholds (white) and the background grayscale images are outside (black), it inverts the image.		

11.2 Edge filtering settings

11.2.1 What is Edge Filtering

[Edge position], [Edge count], [Edge width], [Edge pitch], [Edge angle], [Edge tracking], and [Width tracking] functions are based on the results from edge detection.

As shown to the right, each inspection function provides [Parameters] > [Edge filter] settings. The screen also displays the edge transition waveform during the setup to find the appropriate threshold values for stable edge detection.

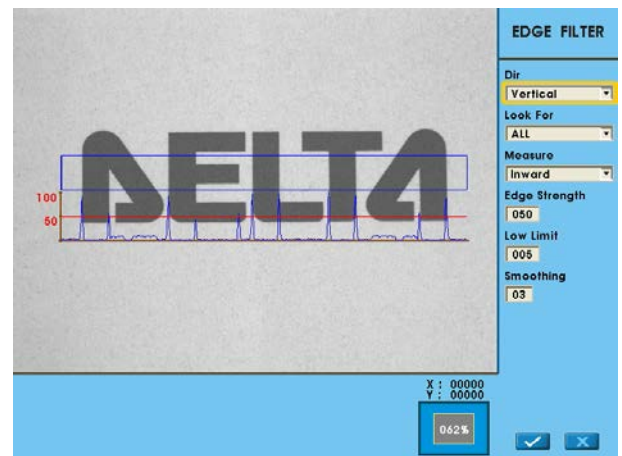

11.2.2 Edge Filtering Details

Edge filtering settings include [Direction], [Look for], [Edge strength], [Lower limit], [Smoothing], [Measure], [Reference], [Pitch upper] and [Pitch lower]. This section describes these settings.

■ **Direction**

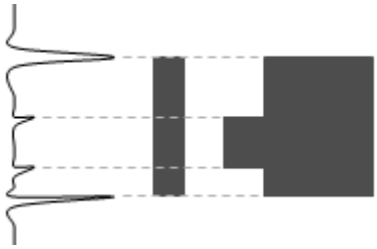
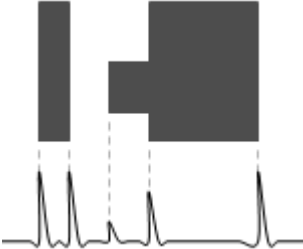
Top to bottom, bottom to top	Left to right, right to left
	
<p>Description: The Edge detection waveform is based on the grayscale gradient in the image. A larger grayscale gradient results in the higher peak that indicates a more distinct edge. The waveform automatically orients itself with the [Direction] of edge scanning.</p>	

■ **Find**

- ✧ Light to dark: Found three edges from bright to dark.
- ✧ Dark to light: Found three edges from dark to bright.
- ✧ All edges: Found total six edges.

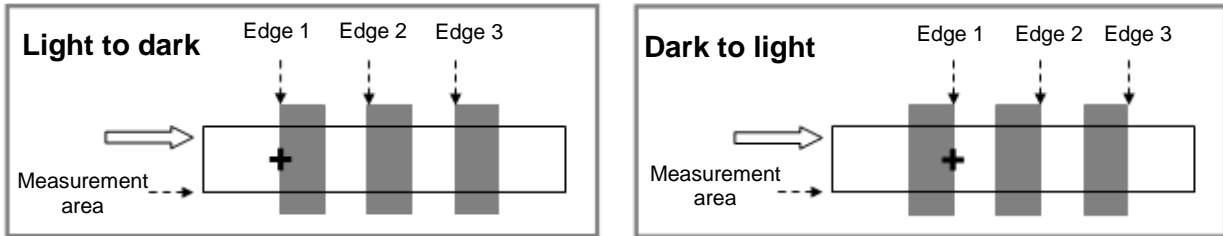

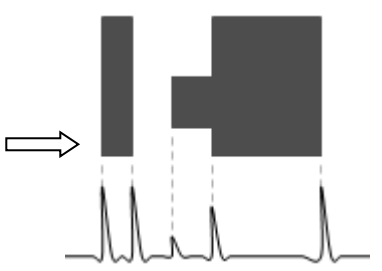
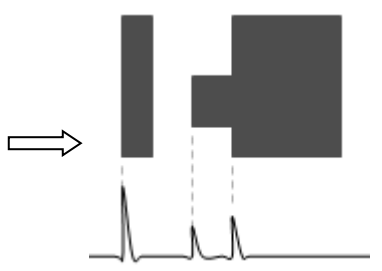
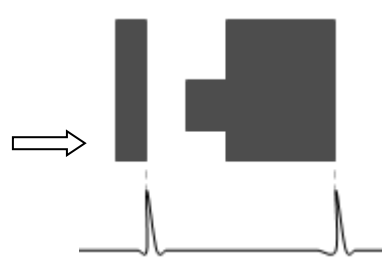
All edges (scan from left to right)	Light to dark (scan from left to right)	Dark to light (scan from left to right)
		
<p>Description: When scanning from left to right, [Light to dark] finds the edges between white and black; [Dark to light] finds the edges between black and white. [All edges] finds all edges with [Light to dark] and [Dark to light] transitions.</p>		

All edges (scan from right to left)	Bright to dark (scan from right to left)	Dark to bright (scan from right to left)
Description: Reverses the results for [Light to dark] and [Dark to light] if you change the scanning direction.		

■ Edge strength (default=50%)

[Edge strength] is the peak threshold for determining the edge. As shown in the picture below, although there are three different peaks, the [Edge strength] threshold filters out the two lower peaks and detects the highest peak as an edge.

With grayscale gradient of 0–255, the maximum edge gradient is 255 when going from pure black to pure white or pure white to pure black. The function automatically detects the minimum and maximum grayscale gradient levels and maps them to 0–100% for the [Edge strength]. If the grayscale gradient levels fall in 50–150, a 50% edge intensity indicates a threshold of $(150 - 50) / 2 + 50 = 100$ (grayscale 0–255).

Using percentage (%) stabilizes the edge detection even if the brightness of the light source changes. If the grayscale gradient levels become 50–250 due to a change in the external light source (with this new range still mapped to 0–100%), the same 50% edge intensity results in the $(250 - 50) / 2 + 50 = 150$ (grayscale 0–255) threshold level. In effect, the function automatically adjusts the threshold when the histogram changes due to the external light source without sacrificing the edge detection performance.

Dark to light, scan from right to left (edge strength=40)	Dark to light, scan from right to left (edge strength=80)
Description: As shown to the left, 40% [Edge strength] results in 2 edges from the first and third peaks. As shown to the right, 80% [Edge strength] results in 1 edge from the third peak.	

■ Lower limit (default=05)

The [Edge strength] function automatically maps grayscale gradient levels of 0–255 to 0–100%, which stabilizes the edge detection under a variable light source.

[Lower limit] sets the absolute grayscale gradient level. A value of 80 (0–255) means that the function filters out and ignores any peak under 80.

■ Smoothing (default=03)

[Smoothing] controls the noise filter performance where a higher value means the function uses more surrounding pixels to average out the current pixel grayscale. The function smoothes the waveform before performing edge detection. Conversely, thinner edges require smaller [Smoothing] values to preserve the edge details.

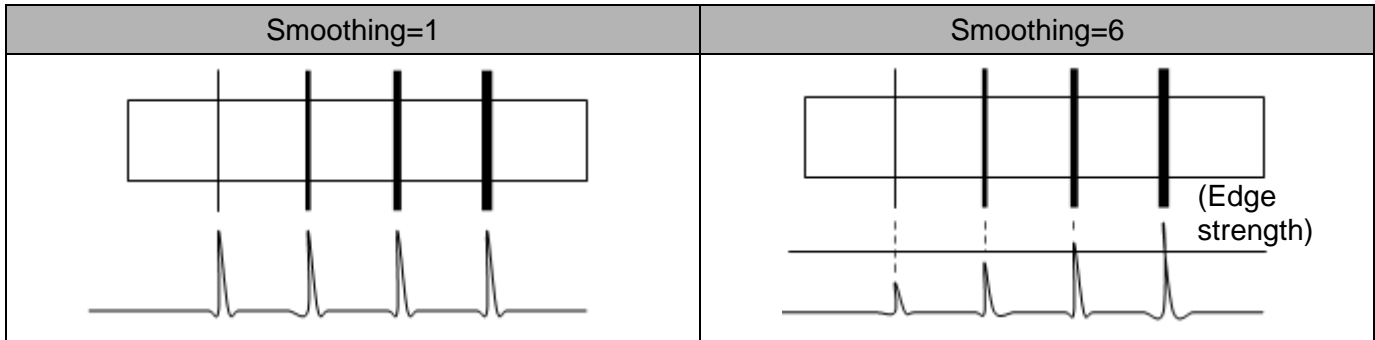

Description: Four different edge widths are as shown.

In the left picture, [Smoothing = 1] disables the pixel averaging filter and therefore the peaks are identical for the four lines.

In the right picture, [Smoothing = 6] enables the pixel averaging filter and therefore the thinner line results in a lower peak. Using peak levels coupled with [Edge strength] to filter out edges 1 and 2, leaving the intended edges 3 and 4.

■ Measure (for edge width and width tracking only)

Select the [Inward] or [Outward] method for measuring the width.

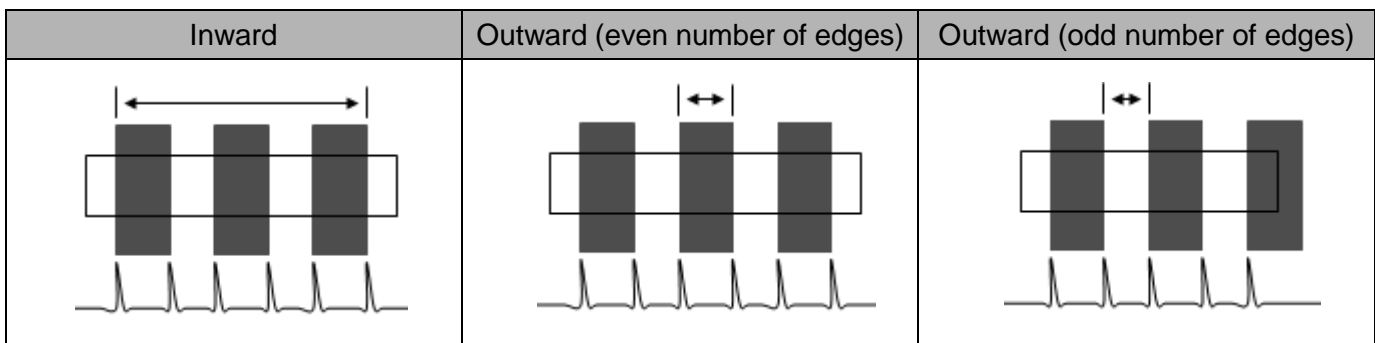

Description: The pictures show the most common three edge measurements.

Inward: The function uses the two outermost edges to calculate the edge distance.

Outward (even number of edges): The function uses the two innermost edges to calculate the edge distance.

Outward (odd number of edges): Because the number of edges is not symmetric, the function uses the innermost left edge to calculate the distance between the two edges.

■ Reference (for edge position and edge pitch only)

Select the nth edge for inspection.

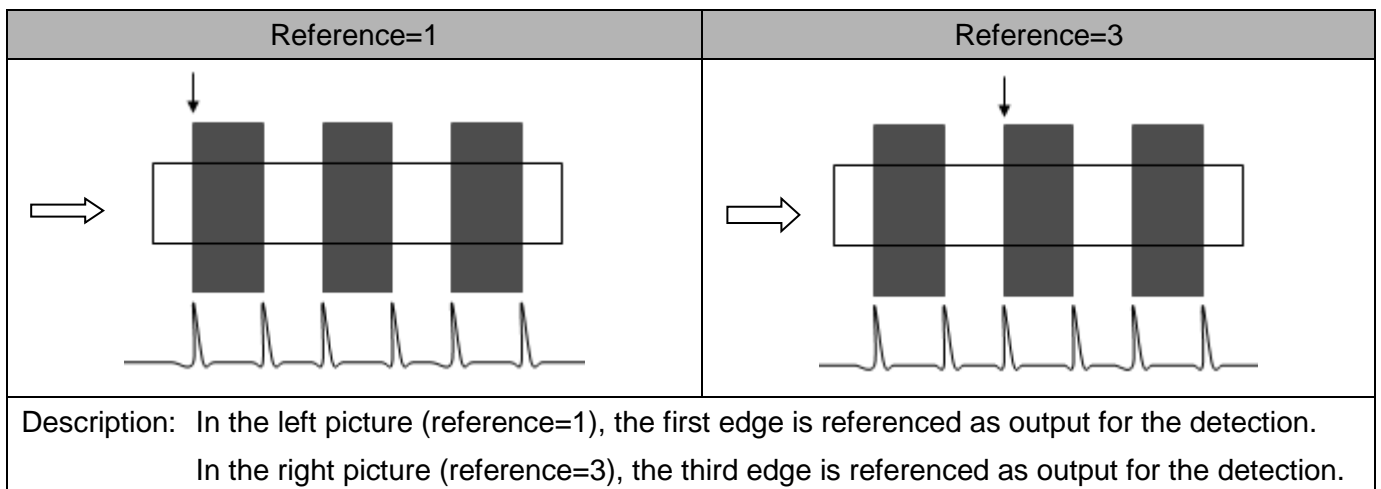

■ Pitch upper/pitch lower (for edge pitch only)

The function can filter the pitch width using the [Pitch upper] and [Pitch lower] parameters.

For example: The function detects four pitch widths of 40, 60, 80, and 100 from [Edge strength] filtering. Setting the [Pitch upper] to 90 and [Pitch lower] to 50, the function filters pitch widths outside this range and results in only two widths (60 and 80).

11.3 Lighting

11.3.1 Lighting Method

Lighting covers the light source as well as the relative position with the camera. This section describes the most common light sources and imaging results.

1. Dark field lighting: Smooth surfaces appear darker

The CCD camera is not in the same axis as the lens and the angle is not perpendicular. Light hitting the smooth surface on the object reflects away from the camera and light bouncing off non-smooth areas scatters into the CCD. As a result, the smooth surfaces appear darker and the rough areas appear brighter.

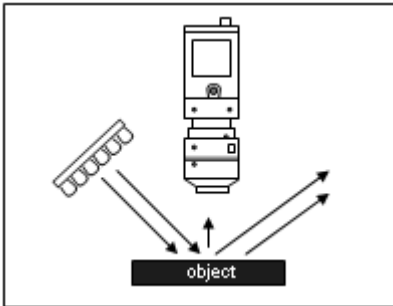

■ Raised text on black plastic



(test item)



(dark field lighting)

2. Bright field lighting: Smooth surfaces appear brighter

The CCD camera and lens are in the same axis as the light source, and the angle is perpendicular. Light directly reflects off the smooth surface on the object into the CCD. As a result, the smooth surfaces appear brighter and the rough areas scatter light away from the CCD to appear darker. Bright field and dark field lighting are inversely related in the resulting image, but avoid excessive glare in bright field lighting.

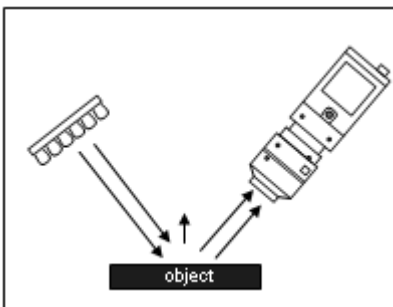

■ Raised text on black plastic



(test item)



(bright field lighting)

3. Front lighting

Front lighting using a ring or strip light source is a common technique for imaging objects. As the ring light is installed at a different angle, it casts a different shadow effect. For highly reflective objects, you can use the diffuser or soft light series to obtain a clear imaging.

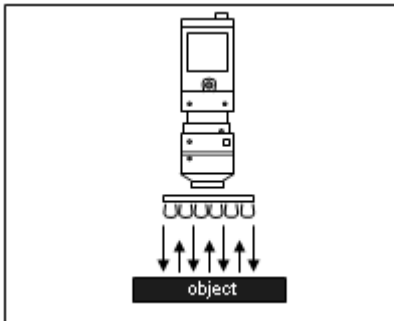

- Lighting on flat text



4. Oblique lighting

Oblique lighting creates horizontal shadows when projected from the side of raised objects. The resulting image has a 2.5D effect. Among the different angles of 0°, 30°, 60°, 90° used for ring lighting, you can use 0° and 30° for oblique lighting.

To reduce errors caused by the shadowing, avoid oblique lighting in edge detection.

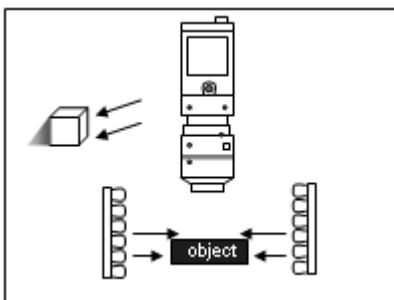

- Printed text on the fuse



(test item)

General



Ring lighting

Low angle



Ring lighting

5. Coaxial lighting

The light source can be either inside or outside the lens. You can also use a beam splitter to create a soft light field to reduce reflections or glare. This is suitable for objects with high reflectivity, such as glass or metallic material.

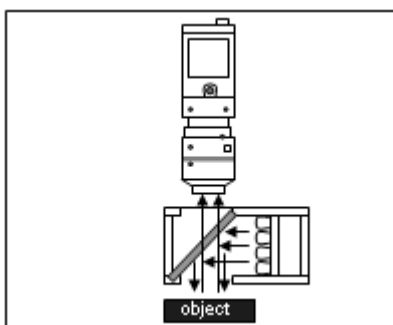

- Measuring a pin connector



(test item)

(general lighting)

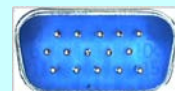

(coaxial lighting)



6. Back lighting

This captures the object outline by shielding the light source, but loses the surface characteristics. Back lighting is generally used for measuring an object's size, positioning, or defect detection.

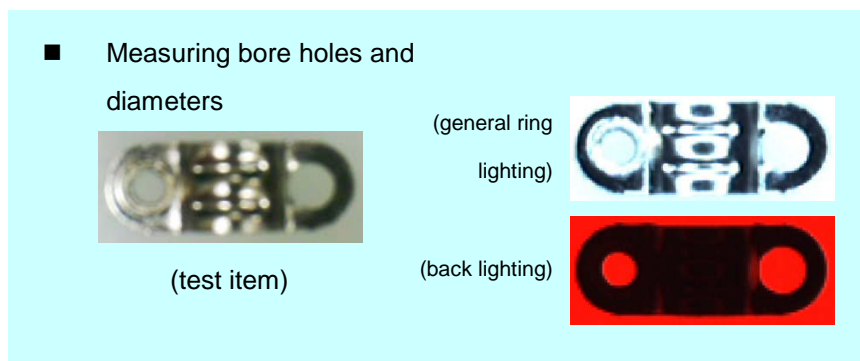
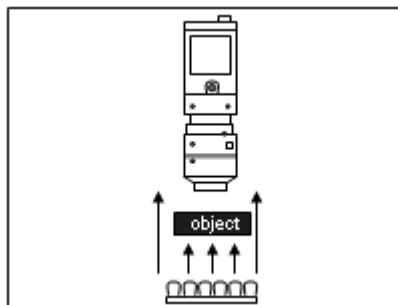

11.4 Four point calibration (Coordinate conversion)

11.4.1 Description of functions

The DMV converts 4 pixel coordinates into 4 machine coordinates, and directly gives the coordinates to the machine.

11.4.2 Use Limitations

The camera's FOV must be large enough to see four points to carry out calibration.

11.4.3 Flow Configuration

- 1) Obtaining 4 machine coordinates: First find 4 positioning points on the work platform, and then use the terminal mechanism of the robotic arm to verify the machine coordinates of the 4 points.

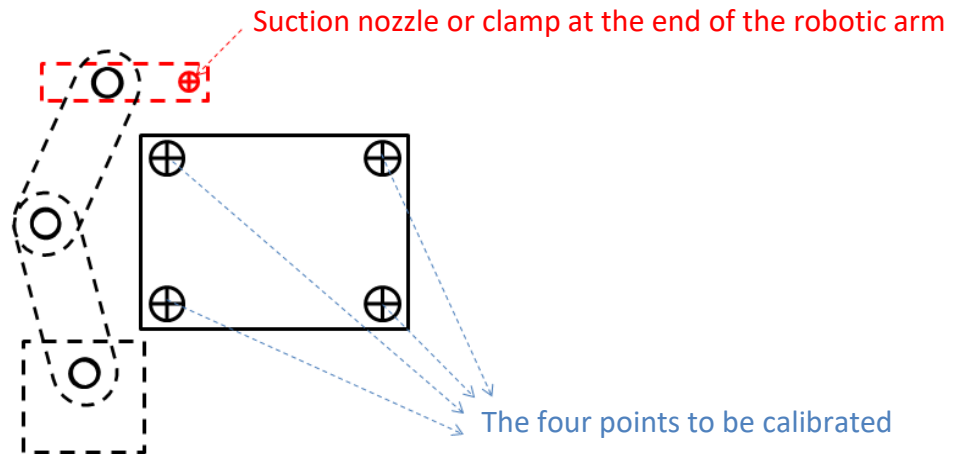

- JOG the arm to the 4 positioning points in the following order, and the 4 machine coordinates can be completed after this is completed.

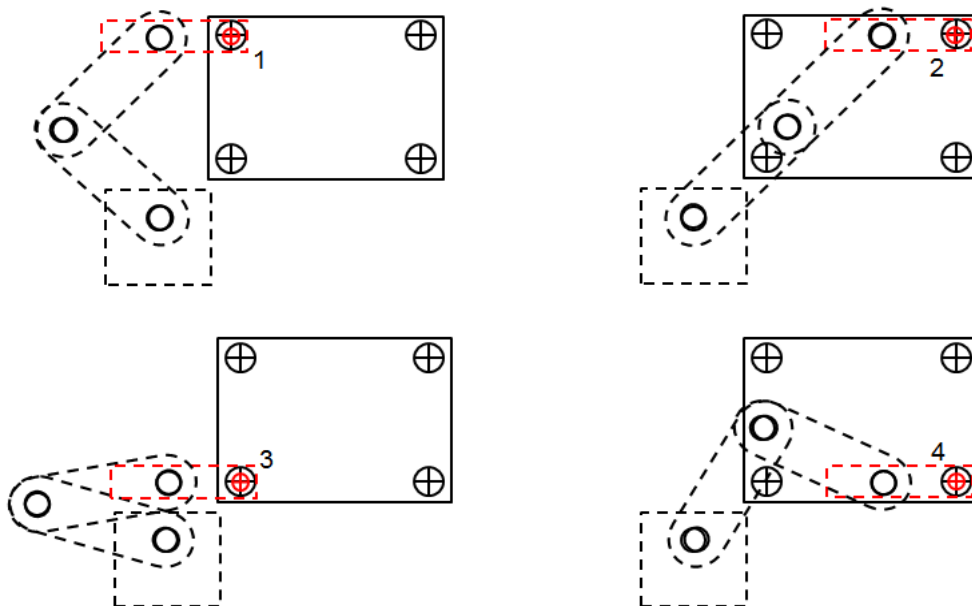

- Assume the 4 machine coordinates are as follows: (0,0), (7,0), (0,4), and (7,4).

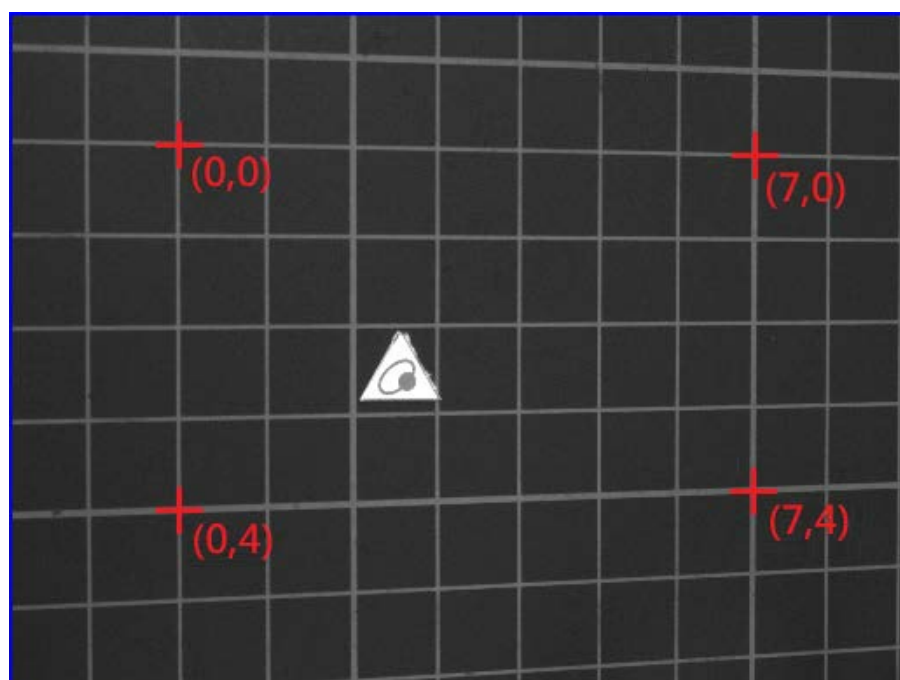

- Four point learning setup: Go to [Program] > [Camera] > [Camera 1/2] > [Coordinate Conversion] to enter the 4 point learning interface, as shown in the figure below.

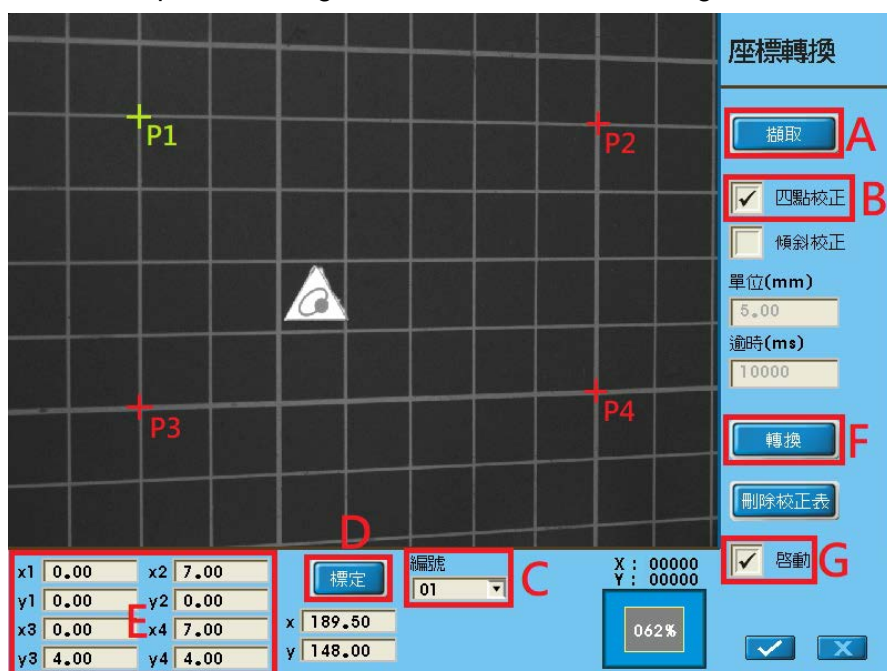

The configuration process is as follow:

- Press to capture the current image.
- Enable the four point calibration function.
- Designate the numbers on the four point learning conversion table. No. 1-32 is provided for users to designate.

D. Four crosshairs will appear on the screen after clicking on Calibration, move these four crosshairs to the four points for four point learning to obtain the four pixel coordinates.

Remark Pay attention to the order of these four points in this step, so the order of pixel coordinates is the same as the order of machine coordinates.

E. Input the machine coordinates of the four points.

F. Click on Conversion.

G. Activate the four point learning function.

This completes the configuration of four point learning. This coordinate conversion tool also provides numerous conversion tables to the customer. Up to 32 conversion tables can be defined, and switch between conversion tables via MODBUS communication.

Remark Address 10C3H is used to designate the conversion table of Camera1, and address 10C4H to designate the conversion table of Camera2.

3) Create a match pattern tool and go to [Output] > [Status] > Output X and Y to Fields 1 and 2, so that users can view coordinate conversion results in RUN mode, as shown in the figure below.

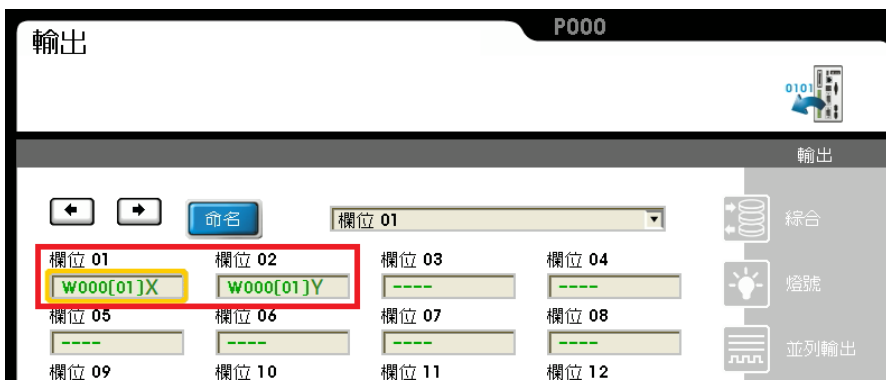

- 4) Go to [System] > [Display] > [Screen] > Enable the function "Display coordinates after conversion in RUN mode"



- 5) Execution results are shown in the figure below.

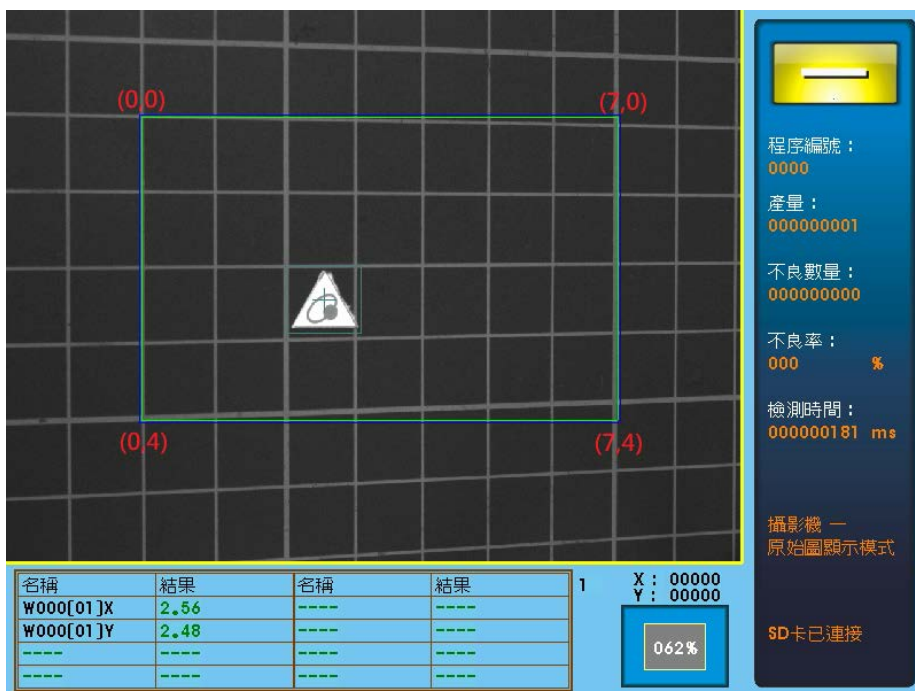

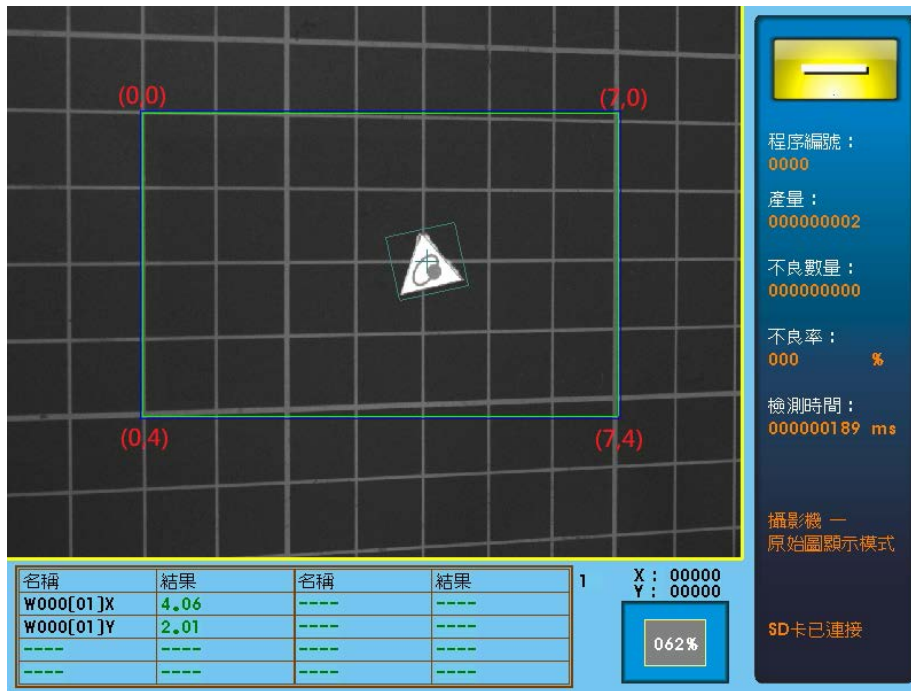

11.5 Trigger Select

11.5.1 What is Trigger Select

If a project is configured as shown in the figure below. If Trigger Select is not used, a single trigger will execute all detection functions. If Trigger Select is used, then a single trigger can be configured to only execute detection functions for the group.

Execute all detection functions for each trigger Execute corresponding detection functions for each trigger

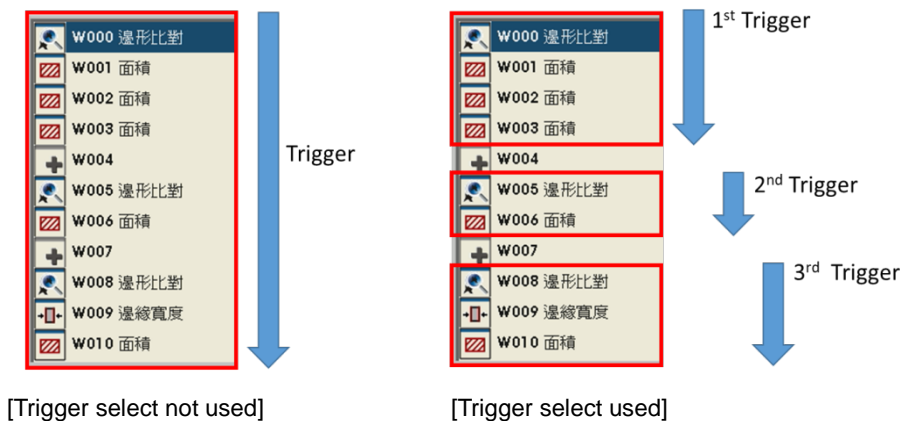

11.5.2 Trigger Select Application Example

Using the inspection window process shown in the figure above as an example, the actual execution result is shown below.

■ Group 1 Execution Result

Set the detection functions in the red frame in the right figure as Group1. After execution, the green light turns on for the first four items [W000-W003].

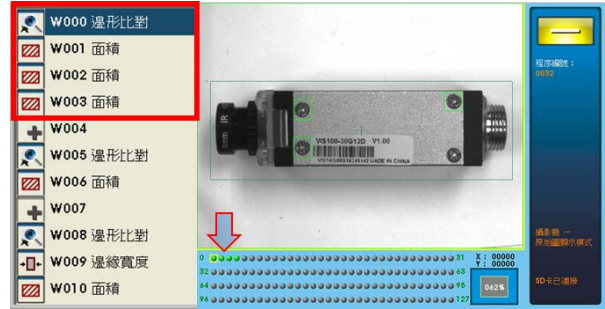

■ Group 2 Execution Result

Set the detection functions in the red frame in the right figure as Group2. After execution, the green light turns on for middle two items [W005&W006].

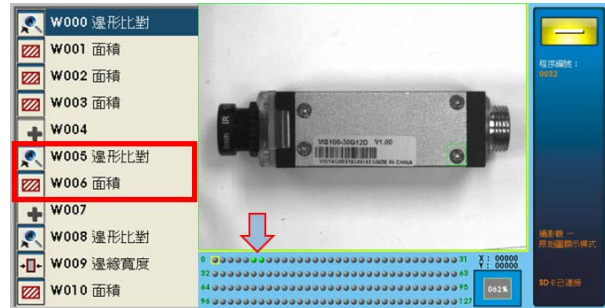

■ Group 3 Execution Result

Set the detection functions in the red frame in the right figure as Group2. After execution, the green light turns on for the last three items [W008-W010].

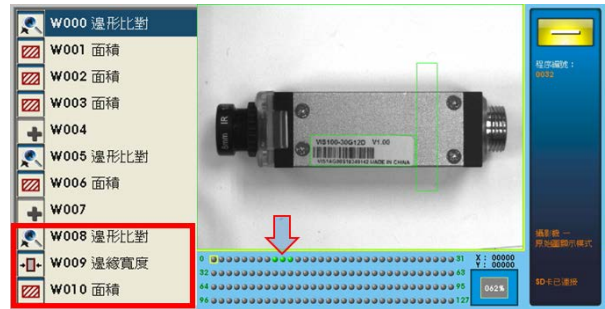

■ Cycle

- 1) After a detection group is triggered and completed, the next detection group will be triggered the next time, and a cycle is completed when all of the groups are completed. The first group is executed again when a cycle is completed, as shown in the flowchart below.

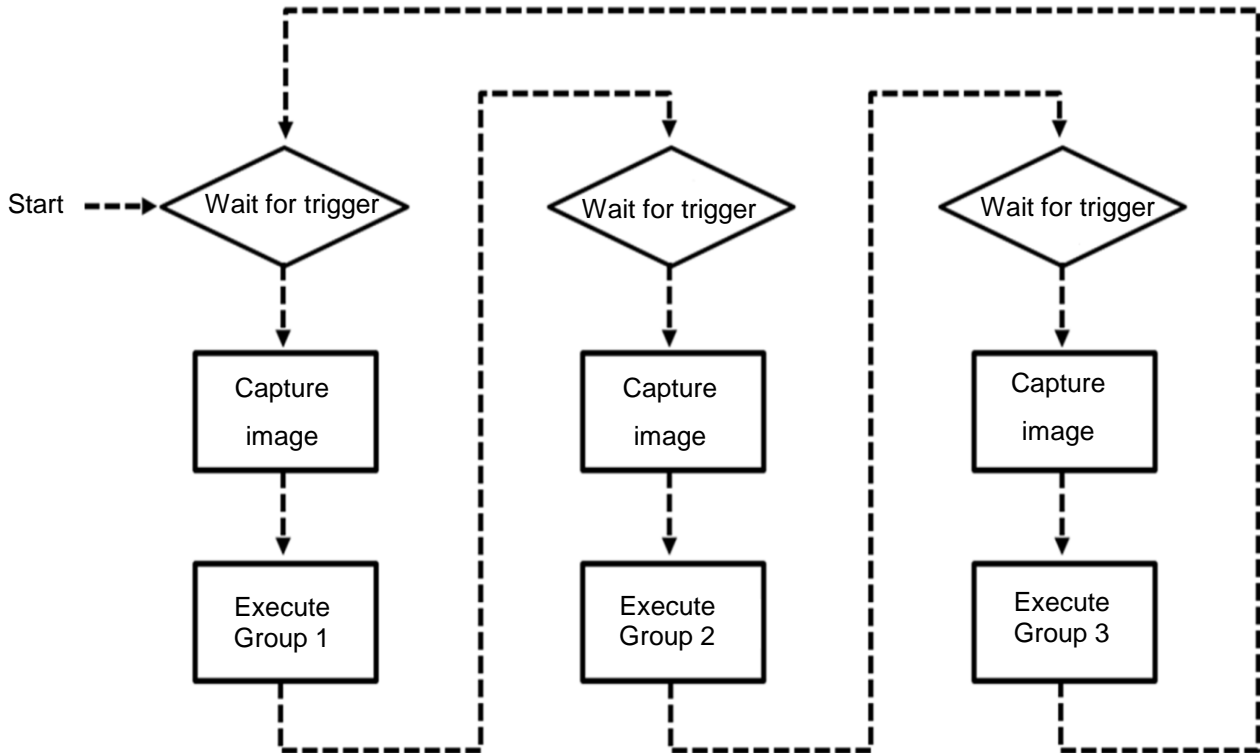

- 2) Set the number of times each group is successfully triggered (e.g., 3, 2, 1). Once the number of times is reached, the next group will be triggered, otherwise the same group will continue to be triggered until it is successfully triggered for the specified number of times. When all groups have been completed, the first group will be executed again, as shown in the flowchart below.

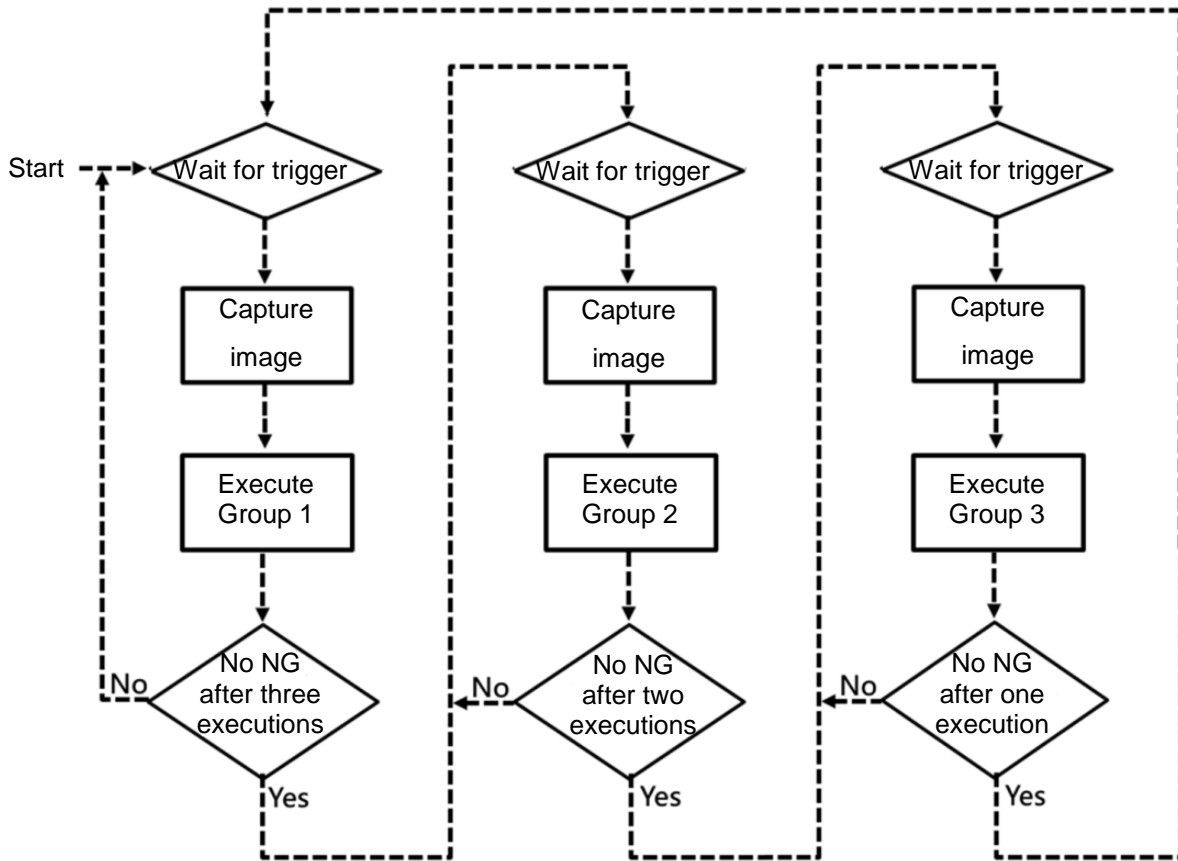

11.5.3 Trigger Select Setup

- First go to [Trigger Select] in [Camera] options to find the settings for Trigger Select, in which Group 1-8 can be configured in [Select Group].



- In the [Select Group] options, select the group to configure, and then select the corresponding detection function for the group in the column below and select [Enable]. Click on the [Confirm] button to exit after completing configuration, and this setting will be executed according to Cycle1 described above.

Group選擇
GROUP 1 開啓 檢測OK 003 次數

<input checked="" type="checkbox"/>	W000 邊形比對
<input checked="" type="checkbox"/>	W001 面積
<input checked="" type="checkbox"/>	W002 面積
<input checked="" type="checkbox"/>	W003 面積

Group選擇
GROUP 2 開啓 檢測OK 002 次數

<input checked="" type="checkbox"/>	W005 邊形比對
<input checked="" type="checkbox"/>	W006 面積

Group選擇
GROUP 3 開啓 檢測OK 001 次數

<input checked="" type="checkbox"/>	W008 邊形比對
<input checked="" type="checkbox"/>	W009 邊緣寬度
<input checked="" type="checkbox"/>	W010 面積

- In the [Select Group] options, select the group to configure, and then select the corresponding detection function for the group in the column below and select [Enable]. Also set the number of successful triggers (as shown in figure 003, 002, 001), and then select the [Detect OK] option. Click on the [Confirm] button to exit after completing configuration, and this setting will be executed according to Cycle2 described above.

Group選擇
GROUP 1 開啓 檢測OK 003 次數

<input checked="" type="checkbox"/>	W000 邊形比對
<input checked="" type="checkbox"/>	W001 面積
<input checked="" type="checkbox"/>	W002 面積
<input checked="" type="checkbox"/>	W003 面積

Group選擇
GROUP 2 開啓 檢測OK 002 次數

<input checked="" type="checkbox"/>	W005 邊形比對
<input checked="" type="checkbox"/>	W006 面積

Group選擇
GROUP 3 開啓 檢測OK 001 次數

<input checked="" type="checkbox"/>	W008 邊形比對
<input checked="" type="checkbox"/>	W009 邊緣寬度
<input checked="" type="checkbox"/>	W010 面積

■ Specify Trigger Select

Communication commands (MODBUS) can also be used to specify the group to execute. Please refer to the description below for commands. After writing command 0001, subsequent triggers will only execute the detection functions in Group2. If it is necessary to switch to other groups, then give another command to change (0000-0007 corresponds to groups 1-8).

Switch Group Number 10C1H(W) (RUN, EDIT mode enabled)

Input string: 010610C10001 27 Return string: 0106 10C10001 27

Description: After a "1" is written, the system will switch to Group 2. The switch is successful if the string returned is identical.

Error Handling: Return string

- :01860376 : Incorrect content or length of write data
- :01860574 : Switch group number was not completed due to timeout